

# Architecture and Engineering

Volume 9 Issue 4 (2024)

ISSN: 2500-0055

## Editorial Board:

Prof. Askar Akaev (Kyrgyzstan)  
Prof. Emeritus Demos Angelides (Greece)  
Mohammad Arif Kamal (India)  
Prof. Stefano Bertocci (Italy)  
Prof. Tigran Dadayan (Armenia)  
Prof. Milton Demosthenous (Cyprus)  
Prof. Josef Eberhardsteiner (Austria)  
Prof. Sergei Evtukov (Russia)  
Prof. Georgiy Esaulov (Russia)  
Prof. Andrew Gale (UK)  
Prof. Theodoros Hatzigogos (Greece)  
Prof. Santiago Huerta Fernandez (Spain)  
Yoshinori Iwasaki (Japan)  
Prof. Jilin Qi (China)  
Prof. Nina Kazhar (Poland)  
Prof. Gela Kipiani (Georgia)  
Prof. Darja Kubečková (Czech Republic)  
Prof. Hoe I. Ling (USA)  
Prof. Evangelia Loukogeorgaki (Greece)  
Prof. Jose Matos (Portugal)  
Prof. Dietmar Mähner (Germany)  
Prof. Saverio Mecca (Italy)  
Prof. Menghong Wang (China)  
Stergios Mitoulis (UK)  
Prof. Valerii Morozov (Russia)  
Prof. Aristotelis Naniopoulos (Greece)  
Sandro Parrinello (Italy)  
Prof. Paolo Puma (Italy)  
Prof. Jaroslaw Rajczyk (Poland)  
Prof. Marlena Rajczyk (Poland)  
Prof. Sergey Sementsov (Russia)  
Anastasios Sextos (Greece)  
Eugene Shesterov (Russia)  
Prof. Alexander Shkarovskiy (Poland)  
Prof. Emeritus Tadatsugu Tanaka (Japan)  
Prof. Sergo Tepnadze (Georgia)  
Sargis Tovmasyan (Armenia)  
Marios Theofanous (UK)  
Georgia Thermou (UK)  
Prof. Yeghiazar Vardanyan (Armenia)  
Ikujiro Wakai (Japan)  
Vardges Yedoyan (Armenia)  
Prof. Askar Zhusupbekov (Kazakhstan)  
Prof. Konstantin Sobolev (USA)  
Michele Rocca (Italy)  
Prof. Sergey Fedosov (Russia)  
Francesco Di Paola (Italy)  
Prof. Alexey Semenov (Russia)



## Editor in Chief:

Professor Evgeny Korolev (Russia)

## Executive Editor:

Anastasia Sidorova (Russia)

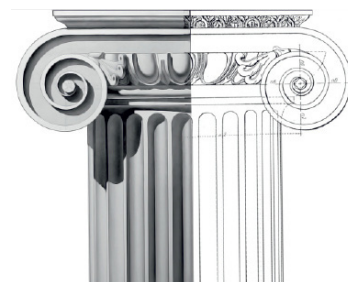

# CONTENTS

## *Architecture*

- 3 **Riyam Rajab Fenjan, Hala Abdulkarem Abdulghani Alsamer, Noor Abdulameer Abd Ali Almansor**  
The virtual documentation role in reformulating the heritage of Basra City
- 19 **Ozge Kartal, Asena Soyluk, Zerrin Funda Urük**  
Development of flood-resistant architectural design proposals on Amasya Yaliboyu house and its surrounding
- 33 **Nagaraju Kaja, Sayak Benarjee**  
Adaptation of vernacular wisdom in contemporary architecture in the hot-dry climate in the context of Indian sub-continent

## *Building operation of buildings and constructions*

- 49 **Mahdi Akhavan, Pooria Rashvand, Mehran Seyed Razzaghi**  
An IoT-based earthquake early warning system with fuzzy logic for utility control in Tehran
- 65 **Iftekhar Rahman, Abhijit Mazumdar**  
Study on local microclimate of outdoor domestic spaces after applying floor area ratio and maximum ground coverage in Dhaka City

## *Civil Engineering*

- 75 **Sergey Fedosov, Ivan Pulyaev, Olga Aleksandrova, Nadezhda Cherednichenko, Evgeniya Derbasova, Yuliya Lezhnina**  
Thermophysical processes in hardening concrete as a factor for quality assurance of erected reinforced concrete structures of transport facilities
- 87 **Haiying Lv, Lei Wang, Huilin Yang, Ruijie Sun, Jin Yang**  
Construction method and application of a basic digital database for the intelligent management and maintenance of existing railway tunnels
- 99 **Valeria Strokova, Christina Urmanova, Georgiy Kalatozi, Sofya Nerovnaya, Lyubov' Shakhova**  
Method to improve the efficiency of volumetric hydrophobisation of protective layers of building structures

## **Architecture and Engineering**

peer-reviewed scientific journal  
Start date: 2016/03  
4 issues per year

### **Founder, Publisher:**

Saint Petersburg State University  
of Architecture and Civil Engineering

### **Indexing:**

Scopus, Russian Science Citation Index, Directory of Open Access Journals (DOAJ), Google Scholar, Index Copernicus, Ulrich's Periodicals Directory, WorldCat, Bielefeld Academic Search Engine (BASE), Library of University of Cambridge and CyberLeninka

### **Corresponding address:**

4 Vtoraya Krasnoarmejskaja Str.,  
St. Petersburg, 190005, Russia

**Website:** <http://aej.spbgasu.ru/>

Phone: +7(812) 316 48 49

Email: [aejeditorialoffice@gmail.com](mailto:aejeditorialoffice@gmail.com)

Date of issue: December 28, 2024

The Journal was re-registered by the Federal Service for Supervision of Communications, Information Technologies and Mass Communications (Roskomnadzor) on May 31, 2017; registration certificate of media organization EI No. FS77-70026

## THE VIRTUAL DOCUMENTATION ROLE IN REFORMULATING THE HERITAGE OF BASRA CITY

Riyam Rajab Fenjan\*, Hala Abdulkarem Abdulghani Alsamer, Noor Abdulameer Abd Ali Almansor

University of Basrah, Basrah, Iraq

\*Corresponding author's email: riyam.rajab@uobasrah.edu.iq

### Abstract

**Introduction:** Virtual reality documentation technology can help urban designers and architects reformulate heritage buildings, especially in Basra City. **The purpose of the study** was to introduce VR technology's technological potential, as it allows the reviving of these buildings. **The following methods were used:** desktop analysis to analyse relevant studies regarding virtual reality documentation and its technologies. The study selected Basra Old Court as a case study. It also conducted two questionnaires that were distributed online, including a link to a virtual heritage platform (VHP). The first questionnaire was directed to a random sample of 20 architects and urban designers to determine the appropriate conservation policy for the case study, depending on their professional opinions. The other questionnaire was directed to (157) residents to justify the results. Moreover, the AutoCAD and Revit programs were used as digital documentation tools to document the case study, producing two VR models that represent two conservation policies (traditional and developmental policy). **The data analysis** showed that experts and residents preferred the VR model I of the heritage building to preserve its original form without additions. **In conclusion**, this approach can examine the selected conservation strategy for the heritage building before the implementation stage.

**Keywords:** virtual reality documentation (VRd); heritage buildings; virtual heritage; realistic simulation; developmental simulation.

### Introduction

Virtual reality documentation (VRd) technology can help urban designers and architects reformulate heritage buildings. This study reviews the documentation in relevant studies to identify methods of documenting heritage buildings using VR technology. Ahmed (2017) highlighted three levels of relationship between heritage and technology. The partial level involves using digital formative models to draw inspiration and incorporate key elements from traditional formative vocabulary. The implicit level involves abstracting, processing traditional, and heritage vocabulary by integrating it with environmental factors. The controlling level uses mathematical equations and digital tools called integration and generation processes between heritage thought and environmental design. The last one is the most abstract level, combining two or more heritage values like form, function, and environmental considerations to create a unique design (Ahmed et al., 2017).

The importance of VRd and its role in controlling the actual space virtually directly through the applications of data, information, and communication technology was studied as one of the vital areas for monitoring and preserving buildings with accurate heritage dimensions (Mahrouq and Al-Haddad, 2001).

Jaillot (2020) examined the digital urban heritage tool that contributes to introducing urban cultural heritage to the community with digital techniques. This includes accessible applications or websites that enhance understanding and increase awareness about the city's development. The participatory property of exchanging knowledge invites professionals and non-professionals to view the urban cultural heritage and participate in creating new knowledge (Jaillot et al, 2020).

On the other hand, smart heritage was introduced to design, rehabilitate, build, manage, and maintain architectural heritage operations to become more straightforward and explicit (López et al., 2018). This concept facilitates designers' giving alternatives for the operations' development through heritage modelling, digitally representing the built environment characteristics (physical, functional, semantic, structure, or existing building) using 3D applications: Revit Autodesk, Tekla Structures, and Bentley Systems.

In terms of documenting methods, El-Din's (2021) study proposed two methods for documenting heritage buildings. The traditional method relies on individual abilities and traditional measurement tools, including written description, drawing, recording, and photography. The modern method

has adopted various heritage modelling techniques, such as photogrammetry and the 3D laser scanner, which is unsuitable for documenting demolished archaeological buildings. El-Din also viewed the BIM technique to document the Seven Domes Building (Seven Girls) in Cairo, with a three-dimensional redesign using the Rivet program to rebuild and complete the monument using bricks as a traditional basic material corresponding to the monument's value (Fig. 1) (El-Din, 2021).

Similarly, Markarian (2018) showed two techniques for photographic architectural documentation in the Ashar River in Basra City: the direct and indirect methods. The direct method includes studying the building in its current form and creating various data based on photographs, while the indirect method collects information and documents from various formal and informal sources. The revival of the destroyed buildings aims to document the state of buildings or the destroyed buildings through various documents, the most important of which are photographs.

Younus et al. (2023) explored the role of VRd in reconstructing the building Khan Hamu Al-qudu in Mosul City, which was destroyed by wars, using the information modelling technique (HBIM). This technique has been considered a strategy for the sustainability of heritage and its survival and continuity within the collective consciousness by connecting digital technology with heritage buildings as a collective product, expressing the city's memory and the connection between the past and the present. The technique used the Revit 2021 program as a BIM program to generate a 3D model. The program was adopted to design doors, windows, and the inner

courtyard, with multiple possibilities to reconstruct them digitally and in their original forms (Fig. 2).

Markus (2023) recently investigated the perception of heritage elements in three dimensions using digital programming. This method allows designers to create creative forms using the options provided by digital programming. The study highlighted the importance of geometric accuracy, adjustments in the design process, resolution levels required to digitize objects and surfaces, distance measurements, and the way the triangular element can be held inside the computer environment (Markus, 2023).

#### *Objectives:*

The research aims to achieve the following:

1. To examine the role of VR technology in documenting neglected heritage buildings in Basrah City and to assist experts in determining a suitable conservation policy for them.

2. To enhance the community's participation in decision-making, recognize their role as key stakeholders, and ensure that the chosen policy meets their sense of belonging.

#### *Literature Review about VRd and potential indicators*

##### *Virtual Documentation (VRd)*

It is the documentation, registration, and rooting of heritage buildings' architectural, historical, and geographical values to preserve them within the spatial and community memory. It also facilitates rehabilitation, development restoration, and future maintenance of the heritage site (Ali and Markarian, 2014). According to Abdulrahman and Ahmed (2006) and Ali and Markarian (2014), VRd embodied in three main points. Firstly, dynamic storage and



Fig. 1. The documentation of the Seven Girls Building El-Din's (2021)



Fig. 2. Khan Hamu Al-qudu (Younus et al., 2023)

retrieval, where the available programs enable the establishment of essential relationships between the components of heritage items in multiple images that cannot be displayed traditionally. Secondly, dynamic display and visibility where models of sites, buildings, and elements of urban heritage can be saved on an accurate scale and displayed in multiple virtual environments that reflect the extent of harmony and compatibility between them. Thereby, it achieves higher degrees of understanding, analysis, and study. Thirdly, dynamic control and processing, documentation is essential for creating comprehensive databases by preparing a modular reference system. It also supports collecting and classifying the city's heritage buildings through images and writings and storing them with similar types for easy viewing and evaluating reality.

*General directions of documentation:*

The documentation depends on the heritage building's values, which are generated through the building's form and function, as which of them bears the change in exchange for the stability of the other party, or both (Fig. 3), which are as follows:

*The reconfiguration direction:*

- *Reuse (non-change direction).* It means modifying, converting, or changing the heritage buildings' uses that have lost their original function by being in a good structural condition to other uses that suit current needs and ensure the protection of the building. Reuse can be optional for buildings whose original function still exists today. It can also be compulsory for buildings whose original function has become extinct, such as ancient temples and cemeteries, to prevent them from becoming abandoned. This is related to the possibility of the building adapting and merging with the city's urban fabric (Serageldin, 1999).

- *Shape reconfiguration (relative change direction).* This direction concerns old buildings that are less significant architecturally and historically. This is to meet the building's new use requirements, which may mean removing or excluding facilities added after its construction. Integrating the new use with the building requires care because historical buildings have shapes subject to the construction conditions or the designer's thoughts, in addition to several factors influencing how to deal with the

building to achieve its purpose functionally and aesthetically (Ismaeel and Torre, 2010).

- *The reconstruction direction (complete change).* A new reconstruction of a destroyed site or building, restoring it entirely or with parts and features that do not exist to copy its appearance and shape characteristic of a specific time. This process takes place in two cases: preserving and improving the aesthetic value and presenting it understandably or consolidating and strengthening the monument to preserve it (Al-Obeidi and Sharif, 2019).

*Considerations of VRD*

The virtual models support the process of imagination and visualization required to realize the importance of the heritage element and its dimensions with the necessity to consider the following concepts (Abdulrahman and Ahmed, 2006).

- *Credibility.* When preparing the heritage element, the proportions in the three dimensions must be achieved correctly. Without documented information about the heritage item, a block model is sufficient without details that may adversely affect its heritage value.

- *Flexibility.* It is related to the preparation, treatment, and display methods. These methods show different stages of the heritage element, including origin, deterioration and transformation, and current status, as each stage can be displayed separately.

- *Details level.* It is one of the essential factors that affect the preparation and processing of digital forms, the proposed presentation style, the way to show it in terms of the processing type approved, and how it relates to the original element's identity within the digital heritage form.

- *The heritage element's perceived value.* It is essential to emphasize the value of the heritage element through its presentation style and level of definition. The digital model highlights the quality of non-existing urbanization in a manner consistent with the available and documented information.

- *Complementary elements of the resulting model.* The importance of the 3D form is represented by the elements used to express the urbanism language, such as lighting, color, texture, space, function, and content in which the heritage element is located.

To conclude, the main indicators and possible measurement values were identified to be applied

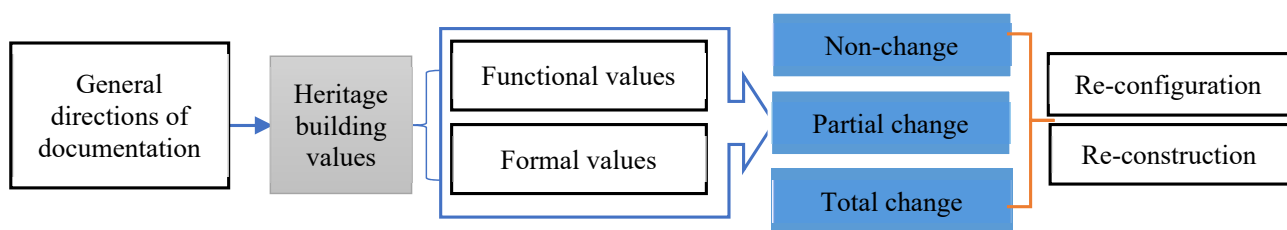

Fig. 3: The general directions of documentation (done by researchers)

to the case study and to measure the role of VRd in reformulating heritage according to the theoretical proposition (Table 1). To facilitate dealing with the main variables, they were coded from A1 to A13. The sub-variables adopted the encoding of their main variable, such as A1; its secondary variables are A11 and A12.

*The VR Technology for Heritage Documentation*

The importance of VR in reviving and preserving architectural heritage is based on adopting new techniques in a three-dimensional virtual environment by adding audio technology as an essential step for preservation and documentation, increasing awareness about local heritage. These techniques are essential steps in the documentation, conservation, and dissemination

of heritage (Alqalami, 2020), in addition to assisting in decision-making in various restoration projects (Jaleel, 2018). The heritage buildings' documentation is essential to preserve, protect, and sustain them. Therefore, it is necessary to understand the building's data, history, and information to establish the conservation process based on a comprehensive knowledge of the building's condition that determines a plan and method of dealing with it without damaging its value (El-Din, 2021). The heritage virtual model also has educational and historical values used to evaluate the building's development by comparing 3D at different times, so it becomes easy to compare the present and the past, evaluate and measure the changes caused by time (Fassi et al., 2016).

Table 1. Indicators Extracted from theoretical Framework

Main Indicators	Variables	Symbols	Sub-variables	Symbols	
General trends for dealing with heritage buildings virtually	Reconfigure the use	A1	Optional restoration of the building's functionality: its original function still exists.	A11	
			Compulsory restoration of the building's functionality: its original function disappeared.	A12	
	Reconfigure the shape	A2	Adding a new formation to the heritage building.	A21	
			Adding detailed elements to traditional facades.	A22	
	Reconstruction direction	A3	Preserving and improving the building's aesthetic value.	A31	
			Strengthening and enhancing the building structurally as a conservation measure.	A32	
VRd possibilities	Structural evaluation of the heritage building	A4	The building's structure is deteriorated, and its heritage image is incomplete.	A41	
			Changing the heritage building's condition (formalism and functionalism).	A42	
VRd considerations	Credibility	A5	The VR models maintain the building's correct proportions.	A51	
			The significance of the VR is to reflect the building's function and heritage.	A52	
	Flexibility	A6	The building's ability to accept change.	At the form level	A61
				At the function level	A62
	level of detail	A7	The compatibility of the added elements with the building's traditional image.	A71	
	The perceived value of the heritage item	A8	The VR models clarify the heritage value.	A81	
In VR models, the building combines heritage and modernized values.			A82		
Complementary elements of the resulting model	A9	The heritage elements are a vivid image of the building's reality.	A91		
		The added contemporary elements gave the building a new image.	A92		
Representation of the heritage building's historical significance in VR	Construction time and its historical age	A10	The building's virtual image preserves its historical dimensions.	A101	
	Its architectural and aesthetic value	A11	The building's aesthetic value is in its traditional form.	A111	
			The building's aesthetic value is in its contemporary form.	A112	
	The event	A12	Changing the reading of the building as it has heritage events reflected in its proposed images.	At the site level and its relationship to the place.	A121
At the level of added detailed treatments.				A122	
Virtual heritage documentation techniques	Simulation	A13	Realistic simulation.	Accepting the virtual image that matched reality.	A131
			Developmental simulation.	Accepting the developed virtual image.	A132

Virtual heritage is the simulation and documentation of the characteristics of heritage sites within a virtual environment using information and communication technologies (Chehab and Nakhil, 2023). This technology provides an immersive VR experience with self-guided interactive visualization produced by computer systems and presented in a three-dimensional artificial form (Eljojo, 2019). It also represents digital resources transformed from the existing natural and cultural heritage, including dynamic or static digital processes created during digitization, such as creation, documentation, preservation, protection, processing, and dissemination (Wang et al., 2020). Its characteristics consist of buildings' reenactment using horizontal standard plans, sections, facades, and physical objects with computer models and animated films to form 3D models to revive heritage buildings that are difficult to rebuild. Partially dilapidated buildings can also be completed; therefore, these models give insight into how the building is partially treated (Fig. 4) (Osman, 2017).

Simulation in design is defined as the construction of geometric digital models using several methods, including traditional simulation using two-dimensional graphics, three-dimensional simulation using photography, and scanning simulation by photogrammetry or laser techniques (Baky, 2020). The simulation is achieved by creating an imaginary model that simulates all the conditions and factors affecting it through a complex 3D image environment, using simulators, which allow one to walk around inside the virtual environment (Jaleel, 2018). The current study classified the simulation into realistic simulation, which creates identical models of reality, and developmental simulation, which builds possibilities that are not identical or imitated but are treated with images showing the inherent potential of the building (Hassan, 2009).

*Virtual heritage platforms* (VHP) are one of the VR technologies. They are research and educational tools that redefine heritage buildings for users through simulation and physical modeling of archaeological sites or data. They have an impact on the people's cultural nutrition by helping them understand the socio-cultural context (Abdelmonem, 2018).

The current study employed a VHP as a documentation tool to meet the research aims. It is easily accessible, as one only needs a smartphone and Internet. It was adopted to collect and present data to the target audience in an interactive and meaningful way. Two platforms were created, the first designed for experts and the other for Basra residents.

#### **The Case study:**

Basra Old Court building is one of the distinguished heritage buildings in the ancient city fabric. In 2023, UNESCO conducted several studies to revive the architectural heritage of ancient buildings in Basra, including this building (Hameed, 2014) (Fig. 5).

*The most important criteria for accrediting this heritage building are:*

- **Historical Value:**

It includes three standard values (Dairy and Mohammed, 2018). Firstly, **the event (regional, national, and local)**: The building is linked to the local events of Basra's old fabric, distinguished by the water canals' presence. It is considered the oldest building for justice and governance after the 1920s, the independence of Iraq, and the beginning of national ownership. Secondly, **the building's age**: The old court was established during the period (1935–1938) with the construction of Al-Maqal Port Airport, the main commercial area in the Al-Ashar Center, the central residential area, and the administrative buildings in the old centre of Basra, (Ocal, 2016). Thirdly, **location**: The court building is distinguished by its location among the distinctive heritage elements of Basra's ancient fabric, such as the Ashar River and the Shanashil houses (Rajab et al., 2022).

- **Architectural value:**

It is achieved by, firstly, **Style**: The building was designed in the English style that prevailed in Basra (1930-1950) regarding the repetition of windows and building materials (Kalman, 1980). **Secondly, Function**: It first appeared as a house of justice under the Basra Court of Appeal and the centre of public administration in the city, which operated from 1938 to 1980. Thirdly, **structural value**: It is displayed in the old English colonial style, as shown in (Fig. 6). **Fourth, aesthetic value**: The building is an architectural icon of the city. Still, it was neglected

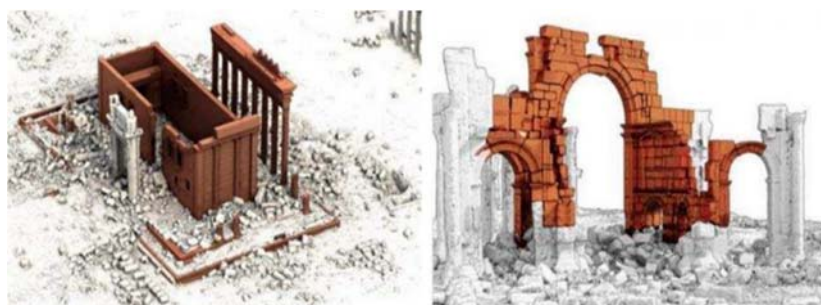

Fig. 4. Completion of the 3D documentation of Palmyra in Syria City (Osman, 2017)

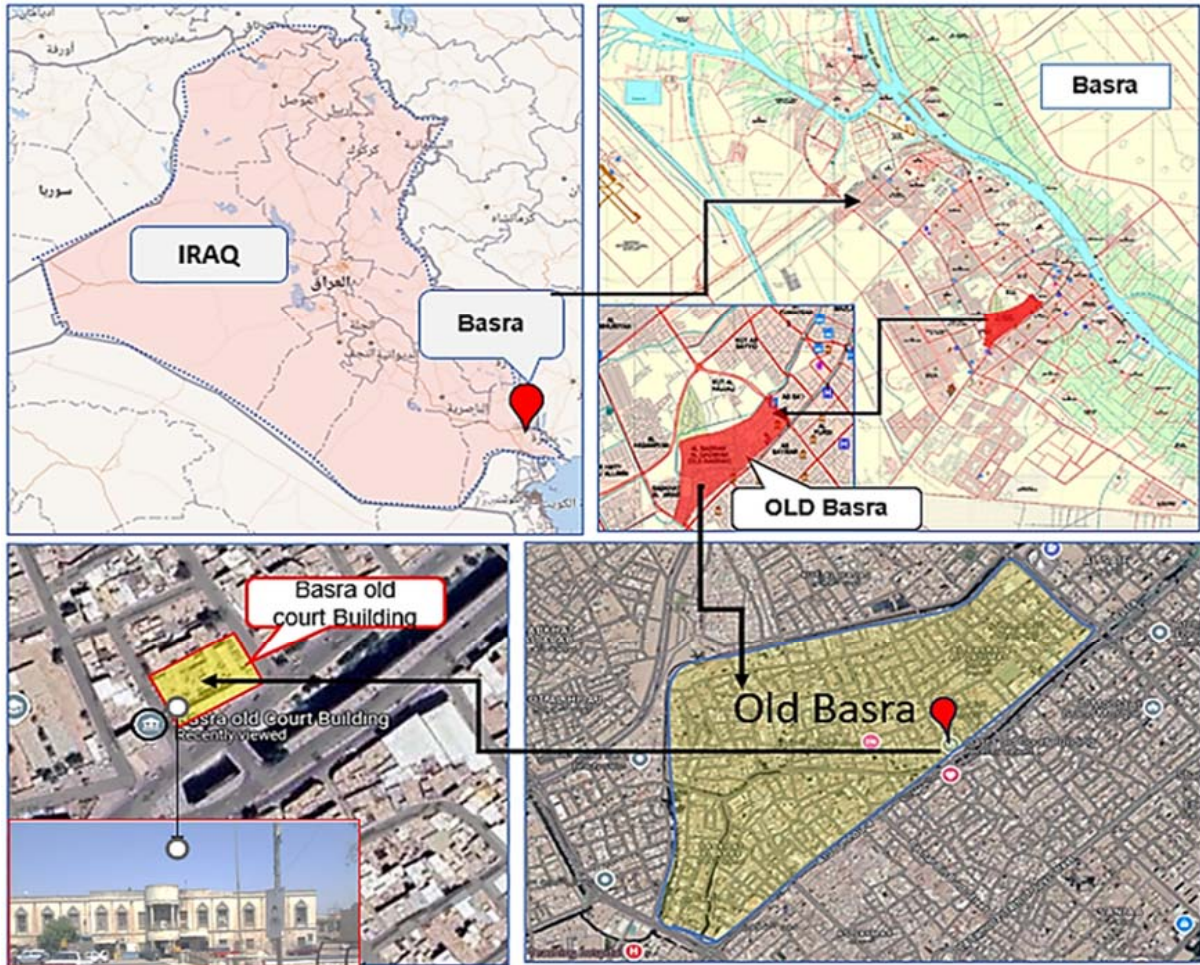

Fig. 5. Case Study Location - Basra Municipality Documents & Google Maps



Fig. 6. The current status of the old court building, photos were taken by researchers



and became an illegal accommodation after the 2003 war, with distorted facades, window details, and building materials (Fig. 6) (Mohammed and Al-Halfawi, 2021). **Fifth, social value:** The building is considered a symbolic landmark that reflects the cultural identity and continuity of the collective memory of Basra city (Kalman, 1980). Fig. 7 shows the case study's 2D schemes, the ground floor and the first floor, drawn using the AutoCAD program.

### Methodology

The current research methodology is divided into stages to thoroughly investigate the use of VR technology in documenting heritage buildings. It is structured around a sequential mixed methods approach and a case study, as illustrated in (Fig. 8). The methods used are:

**Desktop Analysis:** This stage involved collecting data at two levels. The first level included analysing relevant literature to extract indicators, variables, and sub-variables that show the VRd in documenting heritage buildings (see Table 1) and review VRd technologies. The second level involved collecting secondary data for the chosen case study (Basra Old

Court), relying on aerial surveys and photography. The authors used AutoCAD, Rivet, and Lumion programs to create two 3D models representing two conservation policies. The first model (VR model I) retained the building's original appearance and reconstructed it according to the traditional previous vision, see (Fig. 9). The second model (VR Model II) proposed documenting the court building in the modern style by adding heritage elements to the windows, namely the shanshil, see (Fig. 10). Both models were used in the VHP.

**Questionnaire:** The second and third stages include conducting questionnaires distributed online on social media included a VHP link. Both questionnaires were answered using a three-point Likert scale (Agree = 3, Neutral = 2, Disagree = 1). The second stage questionnaire was built based on the extracted variables and sub-variables from the literature review. It was directed to 20 random architecture and urban design experts to determine which conservation policy they would choose. The third stage questionnaire, built based on the results of the previous stage, was directed to residents

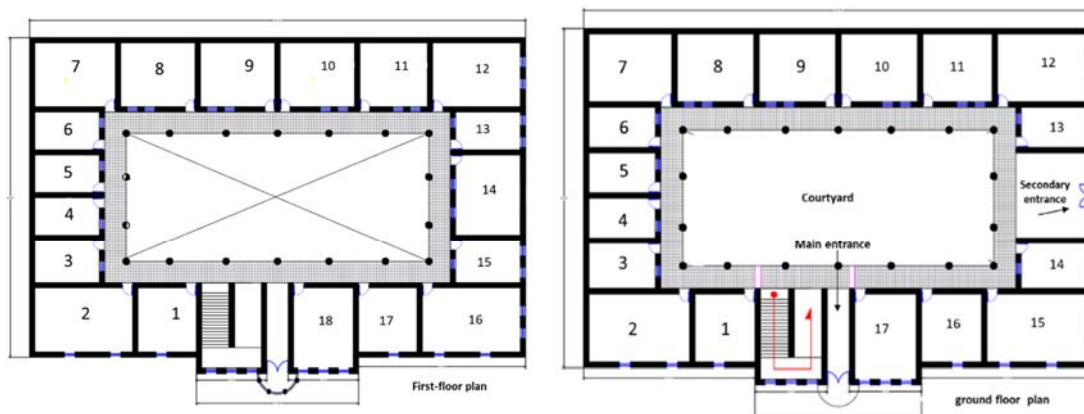

Fig. 7. The plans of the old court building were recreated using the AutoCAD program by researchers

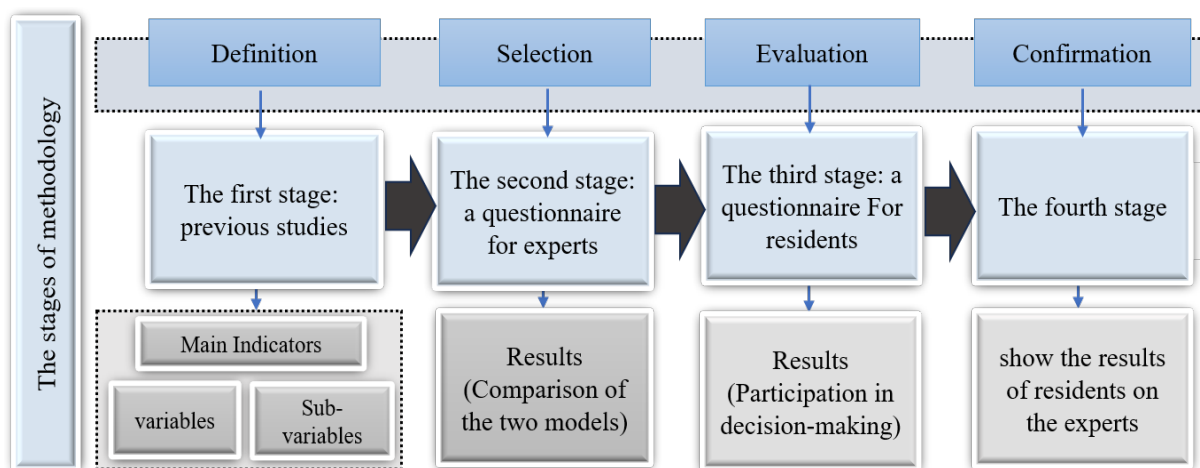

Fig. 8. The research methodology, done by researchers



Fig. 9. VR model I



Fig. 10. VR model II

(157 residents) and examined their satisfaction with the conservation policy the experts chose. The results of this questionnaire justify the research by demonstrating the effectiveness of VR technology in assisting experts in determining the appropriate conservation policy for heritage buildings. The results of both questionnaires were analysed using SPSS.

**Virtual Heritage Platform (VHP):** This platform was selected for its availability and ability to demonstrate the proposed VR models interactively to participants. It was named after the case study (Basra Old Court). The authors created two VHPs to present the proposed models to experts and residents separately (Figs. 11–12). One of the VHPs demonstrated both VR models for experts, while one VR model was included in the VHP designed for residents.

**Results and Discussion**

*The results analysis of the experts' questionnaire*

The data analysis depended on calculating the response percentages of sub-variables under their

related variables. The first indicator, "General trends for dealing with heritage buildings virtually", has three variables. Regarding reconfiguring the court building's use (A1), (Fig. 13) shows that the sub-variable A11 obtained an approval rate of 75 % from experts. In contrast, the sub-variable A12 achieved an approval rate of 35 % for restoring the court building's original function. These response rates indicate that the experts agreed with possibly changing its use to another purpose instead of its original no longer needed function. The figure also shows that the sub-variables A21 and A22 have achieved approval rates of 45 % and 55 % for reconfiguring the shape (A2). The higher rate was for the experts' preference for adding detailed elements to the building's traditional facades.

On the other hand, for reconstruction direction (A3), the sub-variables A31 and A32 have approval rates of 60 % and 57.9, respectively. Although the agreement rates were close, the experts agreed to maintain and improve the building's aesthetic

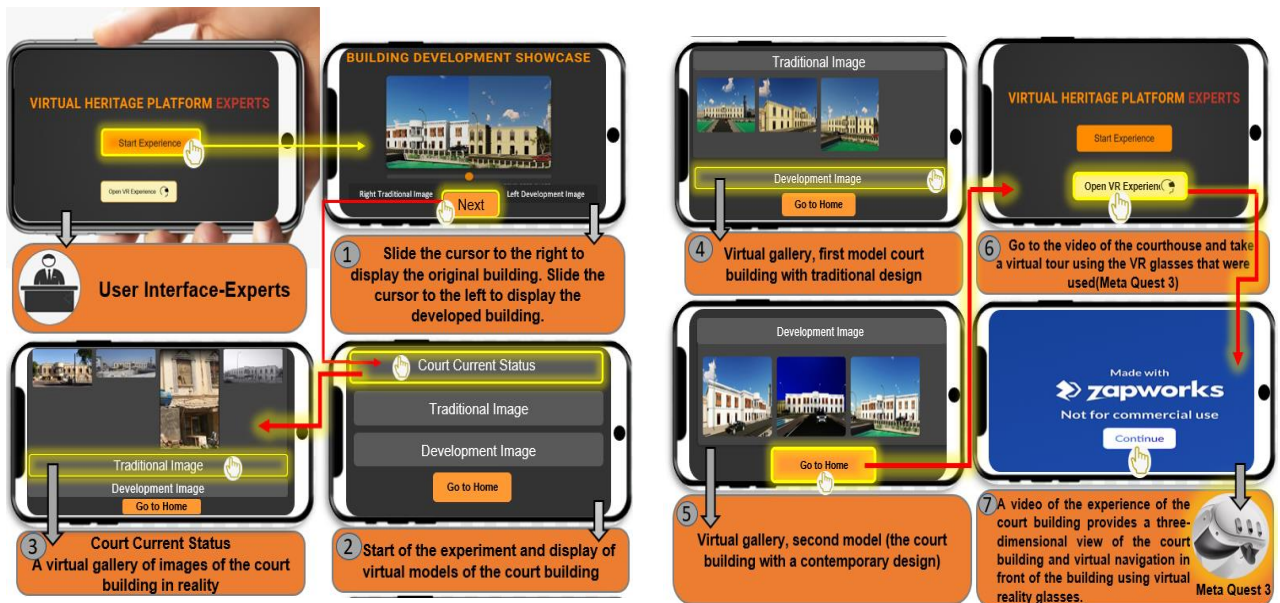

Fig. 11. Virtual Heritage Platform - experts, <https://meee-b672c.web.app/>

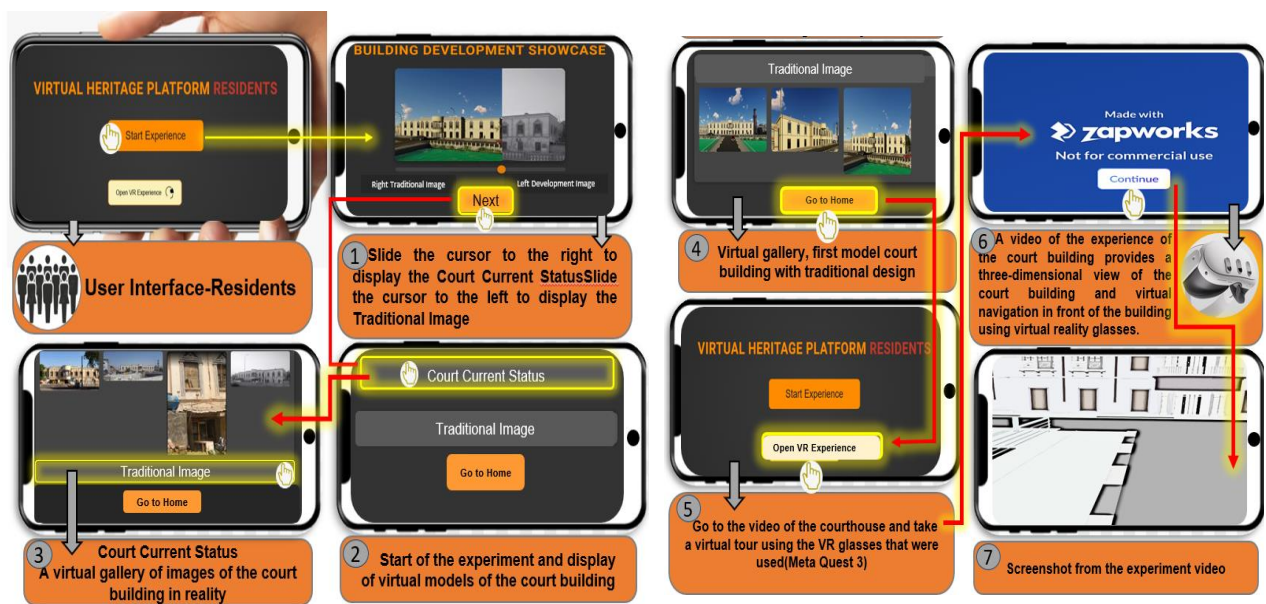

Fig. 12. Virtual Heritage Platform - residents, <https://test-689c7.web.app/>

value and present its traditional image. Based on the results above, the experts tend to choose the traditional image to preserve the court building, as shown in VR model I.

The second indicator, "The VRd possibilities", has one variable, which is Structural evaluation of the heritage building (A4). Regarding (Fig. 14), the sub-variable A41 received an approval rate of 75 %, while A42 and A43 received 50 % each. These rates indicate the experts' agreement on the necessity of VRd for the court due to its poor structural condition to preserve the building's heritage. The results show the importance of preserving the heritage building.

The third indicator, "The VRd considerations", has five variables. Regarding *credibility* (A5), (Fig. 15) shows that the sub-variables A51 and A52 recorded an agreement rate of 60 % each. This indicates the acceptance of the proposed VR models' role in conveying the details of the heritage building by maintaining accurate and close-to-reality representations (A51) and reflecting its function and heritage (A52). For *flexibility* (A6), the figure illustrates that the sub-variable A61 obtained a positive rate of 60 %. This indicates experts' agreement on accepting changes in the court building's form proposed by the VR model II. The

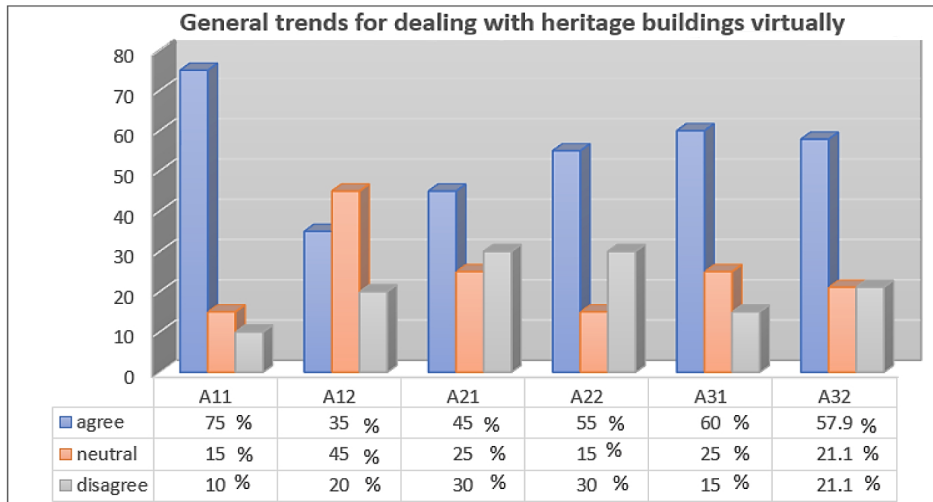

Fig. 13. The results of the first indicator

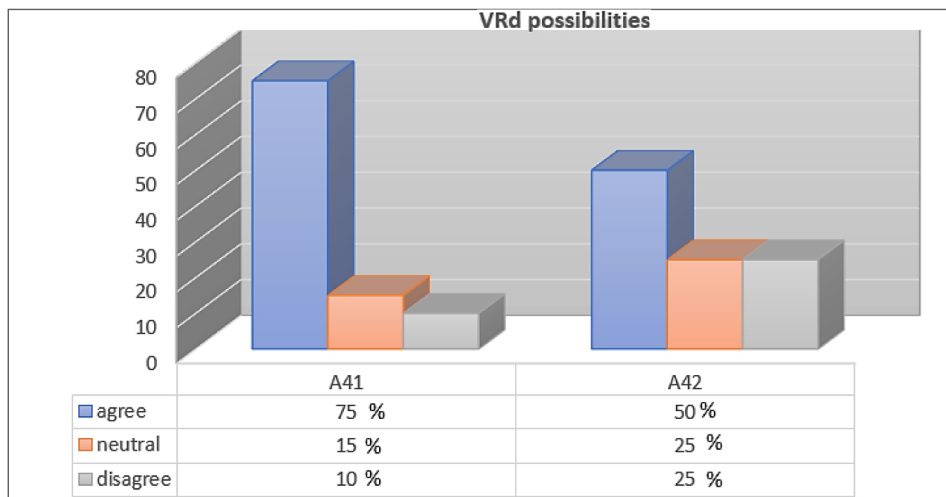

Fig. 14. The results of the second indicator

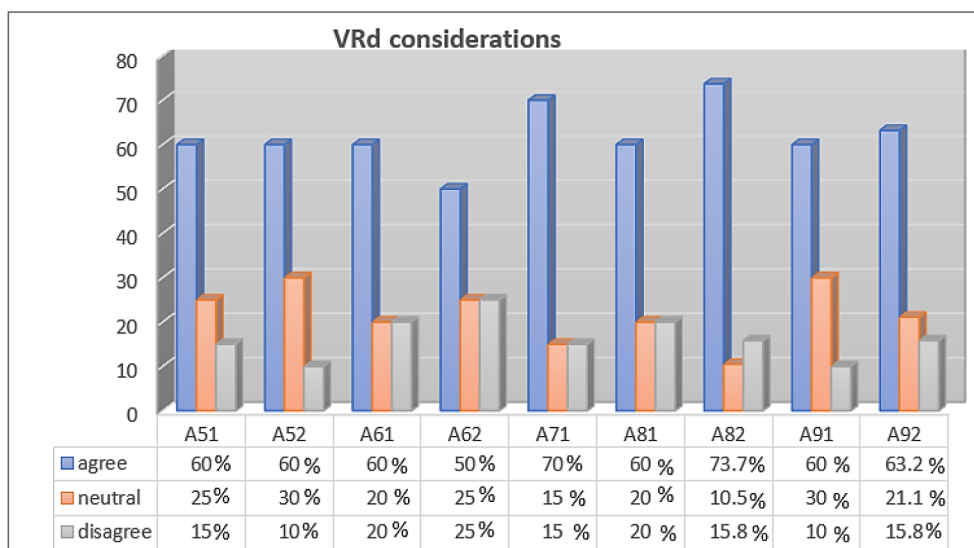

Fig. 15. The results of the third indicator

sub-variable A62 received a 50 % agreement rate regarding the change in the building's function.

In terms of *the level of detail* (A7), A71 achieved an agreement rate of 70 %, indicating experts' agreement on the compatibility of adding new architectural elements with the building's traditional image. For *the perceived value of the heritage item* (A8), the sub-variable A81 received an agreement rate of 60 %. This rate shows that the experts agreed with the clarity of the heritage value of the building, represented by VR I and II models. In comparison, A82 achieved an agreement rate of 73.7 %, representing that the experts also agreed with the proposed heritage and modern value sets in the VR I and II models. *Regarding the complementary elements of the resulting model* (A9), the sub-variables A91 and A92 achieved 60 % and 63 % agreement rates, respectively. Experts' opinions were compatible with both VR models I and II. They preferred the representations in VR model II (A92) more than those representing heritage elements as live images of the building's reality in VR model I (A91). Based on the previous discussed results of A6, A7, and A9, the experts tend to choose the VR model II.

The fourth indicator, "Representation of the heritage building's historical significance in VR", has three variables. Regarding the building's construction time and historical age (A10) and the building's architectural and aesthetic value (A11), (Fig. 16) shows that the sub-variables A101 and A111 obtained an agreement rate of 55 % each. This indicates that the experts agreed on the ability of the VR model I to preserve the temporal dimensions of the heritage building and represent its aesthetic value in its traditional form. However, only 45 % of the experts agreed with the VR model II to enhance the aesthetic value of the building in its contemporary form. For the variable "changing

the reading of the building for having heritage events reflected in its proposed VR models" (A12), the experts agreed by 60 % with the sub-variables A121 and A122. The percentage indicates a change in the reading of the building between the traditional and contemporary forms at the levels of the site, its relationship to the place (A121), and the added detailed treatments (A122).

The fifth indicator, "Virtual heritage documentation techniques", has one variable: simulation (A13). In terms of realistic simulation, (Fig. 17) shows that the sub-variable A131 gained 65 % of the agreement rate, while they agreed with A132 and achieved 55 % of the agreement rate. These results demonstrate that the experts preferred conserving the heritage building to match its original traditional image. In other words, they chose the VR model I rather than the VR model II.

In conclusion, the results of the experts' questionnaire indicate that the experts chose the court building's VR model I as a conservation policy to maintain its original shape without additions.

*The results analysis of the residents' questionnaire*

The residents' questionnaire was built using Google Forms based on the results of the experts' questionnaire. There were 157 total answers representing various age groups, genders, and educational levels. The fewer responses were because this could be their first time participating in an online survey. The data was analysed using SPSS, and answer percentages for five questions were calculated.

As shown in Table 2, 78.4 % of the residents agreed with the first question regarding choosing the VR model I proposed to conserve the court building. For the second question, 67 % of the respondents agreed that VR model I reflected part of the Basra ancient heritage, while 18.4 % of them disagreed.

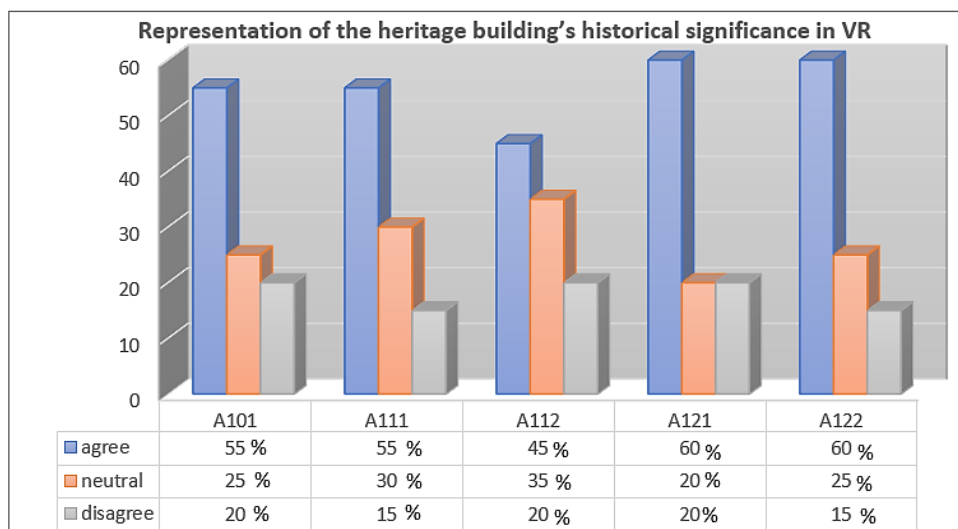

Fig. 16. The results of the fourth indicator

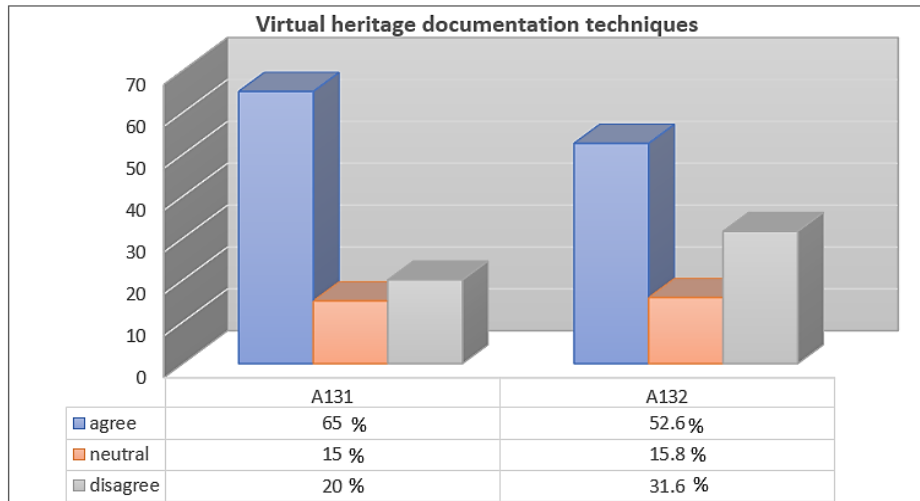

Fig. 17. The results of the fifth indicator

This indicates that around two-thirds of the examined residents knew the city’s heritage buildings. However, 33.1 % of the examined residents still need to gain cultural knowledge about the city’s heritage buildings. Concerning the third question, around 59 % of respondents agreed that the proposed VR model I consistent with the surrounding area. Nevertheless, 18.5 % of the respondents disagreed with its ability to be compatible with the surrounding area, while 22.9 % of respondents were neutral with their answers. The higher rate of responses to the first and third questions is compatible with experts’ opinions in selecting VR model I.

For the fourth question, 93 % of respondents expressed their willingness to participate in future decision-making about heritage buildings in Basra City. This high level of community engagement reflects the importance of community participation in selecting development policies for heritage

buildings. It fosters optimism about the future of heritage conservation in Basra City.

In conclusion, the results confirm the residents of Old Basra’s alignment with the expert evaluations in the VR model I. In other words, the results of the residents’ questionnaire affirm the suitability of the selected conservation policy by experts, which leads to its assistance to experts in their work field.

**Conclusion**

- The proposed models presented by the case study highlight the role of VR in shaping heritage and enabling realistic documentation and future vision. This gives designers a high potential to digitally preserve the heritage and make informed decisions regarding appropriate changes, thus avoiding sudden real-world changes without realizing the negative impacts that could diminish the building’s heritage significance.

Table 2. Residents’ Questionnaire Results

Questions		Answers					
		Agree		Neutral		Disagree	
		No.	Percentage	No.	Percentage	No.	Percentage
Q1	Based on images of the old court building, what do you think about the building’s model as a proposal for restoration?	122	77.7 %	25	15.9 %	10	6.4 %
Q2	Does the attached image of the building on the platform reflect part of Basra’s ancient heritage?	105	66.9 %	23	14.6 %	29	18.5 %
Q3	Do you find that the proposed restoration for the court building is consistent with the surrounding area?	92	58.6 %	36	22.9 %	29	18.5 %
Q4	Would you like to participate in future decision-making about the heritage buildings in your city?	146	93 %	10	6.4 %	1	0.6 %
Q5	What is your experience assessment of the platform in viewing the heritage buildings images of your city?	Good		Average		Poor	
		No.	Percentage	No.	Percentage	No.	Percentage
		134	85.4 %	20	12.7 %	3	1.9 %

- The high potential of VR in providing credibility and flexibility in digitally interacting with the building allows for precise changes that align with the reality of the heritage structure.

- The VR is an influential factor in shaping and documenting heritage, utilizing the features of virtual programs that enhance and enable multiple options for original documentation or formalism review for reconstruction and utilization.

- Digital documentation processes can be applied to all the heritage building's structural conditions, whether deteriorating or incomplete. It can also provide a developmental vision for the worn-out heritage structure to present a new contemporary image, thus giving it longevity.

- The documentation process accurately reveals the heritage dimensions, including the building materials, the surrounding external environment, and even the building's history. This allows designers and viewers to perceive the building's realistic image, making it a continuous landmark connected to its time and place.

- The role of VR is to improve the image of the future vision of the building before reformulating and implementing the possible possibilities in formulating

heritage buildings. VR helps decision makers make the correct design decision before implementation and helps revive heritage in possible forms.

- VR can play a crucial role in preserving our collective heritage. Its power extends beyond preservation to serve as an educational tool, reminding society of the importance of buildings damaged or lost throughout history due to human, technological, or environmental factors.

- Enhancing the community's participation in decision-making regarding selecting the development policy for heritage buildings that suit its needs increases the sense of community and the preservation of its historical heritage.

- This reflects the role of VR in helping architects and urban designers document the heritage building through digital platforms for virtual documentation that facilitated the exploration of the court building. It also enhances interaction and immersion through a virtual exhibit that includes images and videos of the building viewed through virtual reality goggles.

#### **Acknowledgements**

The authors thank the participants (experts and Basra residents) for completing the questionnaires and providing sufficient data for the study.

**References:**

- Abdelmonem, M. G. (2017). Navigating virtual heritage applications for historic cities in the Middle East. In *Proceedings of the 2017 23rd International Conference on Virtual Systems and Multimedia, VSMM 2017. Institute of Electrical and Electronics Engineers Inc.*, pp. 1–8. DOI: 10.1109/VSMM.2017.8346279.
- Al-Harkan, A. A. R. and Sayed, A. O. M. (2006). Technology of digital urban heritage: towards an interactive model for documenting and presenting urban heritage. *Journal of King Saud University-Architecture and Planning*, Vol. 18 Issue 1, pp. 77–108.
- Ahmed, A. H. M. and Hassan, A. H. M. (2017). Reviving the vocabulary of heritage architecture as one of the directions of technological innovation in twenty-first-century architecture towards a contemporary architecture compatible with the environment. *Journal of Al Azhar University Engineering Sector*, Vol. 42, Issue 12, pp. 429–439. DOI: 10.21608/aej.2017.19270.
- Al-Obeidi, M. and Sharif, A. (2019). An analytical study of the Old City at the planning and design levels, Baheth. *International Scientific Journal of Architecture, Engineering and Technology*, Vol. 2, Issue 2, pp. 21–36. DOI: 10.21625/baheth.v2i2.546.
- Ali, K. I. and Markarian, A. S. K. (2014). Documentation concept in architecture documentation and analytic study of foreigner's architecture in Basra City, *Engineering and Technology Journal*. University of Technology-Iraq, Vol. 32, Issue 11, pp. 377–392. DOI: 10.30684/ETJ.32.11A.20.
- Alqalami, T. A. (2020). Dynamic transparency in design: the revival of environmental sustainability in design elements of Iraqi buildings. *Heliyon*, Volume 6, Issue 11, p. e05565. DOI: 10.1016/j.heliyon.2020.e05565.
- Baky, A. A.-G. A. (2020). Using digital modeling to simulate heritage furniture and manufacturing it digitally. *Journal of Architecture, Arts and Humanities*, Volume 5, Issue 24, pp. 70–87. DOI: 10.21608/mjaf.2020.20838.1418.
- Chehab, A. and Nakhil, B. (2023) Exploring virtual reality as an approach to resurrect destroyed historical buildings — an approach to revive the destroyed "egg building" through VR. *Architecture and Planning Journal (APJ)*, Vol. 28, Issue 3, p. 17. DOI: 10.54729/2789-8547.1212.
- Dairy, A.-I. N. and Mohammed, F. A.-R. (2018). Climate and its relationship to the design of old residential houses (Shanashil) in Basra, *Journal of Basra researches for Human Sciences*. Basrah University, Volume 43, Issue 1, pp. 348–364.
- El-Din, H. A. I. S. (2021). Documenting and reconstructing destructed monuments from old documents using 3D models. *The Yearbook of the General Union of Arab Archaeologists*, Vol. 24, Issue 1, pp. 393–415. DOI: 10.21608/cguaa.2021.60833.1077.
- Eljojo, A. (2019). Knowledge Level of Architectural Preservation Workers in Gaza Strip in Virtual Reality and its Applications. *The fourth International Conference on architectural cultural heritage for the rehabilitation of archaeological sites and buildings*. Gaza Strip, Palestine: Department of Architecture, Faculty of Engineering, Islamic University of Gaza. Available at: [https://www.researchgate.net/publication/335096752\\_mstwy\\_mrft\\_alamlyn\\_fy\\_alwthqy\\_almary\\_fy\\_qta\\_ghzt\\_balwaq\\_alaftrady\\_wttbyqath](https://www.researchgate.net/publication/335096752_mstwy_mrft_alamlyn_fy_alwthqy_almary_fy_qta_ghzt_balwaq_alaftrady_wttbyqath) [Date accessed 20 June 2024].
- Fassi, F., Mandelli, A., Teruggi, S., Rechichi, F., Fiorillo, F., and Achille, C. (2016). VR for Cultural Heritage A VR-WEB-BIM for the Future Maintenance of Milan's Cathedral. In: De Paolis, L., Mongelli, A. (eds) *Augmented Reality, Virtual Reality, and Computer Graphics. AVR 2016. Lecture Notes in Computer Science*, vol 9769. Springer, Cham. DOI: 10.1007/978-3-319-40651-0\_12.
- Hameed, R. A. A.-M. (2014). The History of Maps in Basrah Governorate. *Basra Studies Journal*. Basrah University, Vol. 17, Issue 1994–4721, pp. 91–118.
- Hassan, N. A.-M. (2009). Imitation Form Strategy of Nature in Traditional Arabic City. *Iraqi Journal of Architecture and Planning*, Vol. 8, Issue 16, pp. 300–331.
- Ismaeel, E. and Torre, S. (2010). Meta-Modelling For The Conservation Of The Cultural Heritage, in *International Planning Conference on Challenges for Urban Development in Iraq*. Dohuk.
- Jaillet, V., Istasse, M., Servigne S., Gesquière, G., Rautenberg, M., and Lefort I. (2020). Describing, comparing and analyzing digital urban heritage tools: A methodology designed with a multidisciplinary approach. *Digital Applications in Archaeology and Cultural Heritage*, Vol. 17, p. e00135. DOI: 10.1016/j.daach.2020.e00135.
- Jaleel, W. D. A. (2018). Generating shape and relationship to structure in digital architecture. *Journal of University of Babylon for Pure and Applied Sciences*. Vol. 16, Issue 2, pp. 195–214. DOI: 10.29196/jub.v26i2.839.
- Kalman, H. (1980). *The Evaluation of Historic Buildings*. Published under authority of the Minister of the Environment. 2<sup>nd</sup> edn.
- López, F. J., Lerones, P. M., Llamas, J., Gómez-García-Bermejo, J., and Zalama, E. (2018). A review of heritage building information modeling (H-BIM). *Multimodal Technologies and Interaction*, Vol. 2, Issue 2, p. 21. DOI: 10.3390/mti2020021.



- Mahrouq, A. and Al-Haddad, B. (2001). Gaza City : Virtual space and the control of physical space, *CORP*, pp. 397–402. Available at: [https://archive.corp.at/cdrom2001/corp2001/archiv/pdf\\_corp01/01\\_Mahrouq\\_FR.pdf](https://archive.corp.at/cdrom2001/corp2001/archiv/pdf_corp01/01_Mahrouq_FR.pdf) [Date accessed 20 June 2024].
- Markarian, A. (2018). Photographic documentation and its role in the revival of virtual architectural heritage “A study of the river front of the Ashar river for the period 1950-1930. *Thi-Qar University Journal for Engineering Sciences*, Vol. 9, Issue 2, pp. 142–153. DOI: 10.31663/tqjes.9.2.335(2018).
- Mohammed, M. S. M. and Al-Halfawi, A. M. K. (2021). Entry of numerical evaluation to indicate the importance of the degree of value buildings. *Journal of Al-Azhar University Engineering Sector*, Vol. 16, Issue 59, pp. 395–412. DOI: 10.21608/AUEJ.2021.166724.
- Ocal, T. (2016). The effect of field trips to historical cultural heritage sites on teacher candidates. academic knowledge and their sensitivity. *Creative Education*, No 7, pp. 376–386. DOI: 10.4236/CE.2016.72037.
- Osman, E. (2017). Virtual reality as one of the mechanisms of documentation, preservation and development of knowledge of urban heritage, in *The first Arab Conference for restoration and reconstruction-protection of urban heritage sites and buildings*, pp. 1–20. Available at: [https://www.academia.edu/37011512/ظافحل\\_اوقيشوتل\\_تايلأ\\_دحاك\\_يضاارتقال\\_عقاول](https://www.academia.edu/37011512/ظافحل_اوقيشوتل_تايلأ_دحاك_يضاارتقال_عقاول) [Date accessed 21 June 2024].
- Fenjan, R. R., Fadhil, A., Nassif, H. A., and Alyasari, H. I. (2022). Activating urban public spaces surrounding heritage rivers; Al Ashar river in Basra-Iraq as a case study. *Journal of Engineering Science and Technology*, Vol. 17, Issue 1, pp. 713–0729.
- Serageldin, I. (1999). *Very Special Places: The Architecture and Economics of Intervening in Historic Cities*. Washington, DC: *The International Bank for Reconstruction and Development/THE WORLD BANK*.
- Storeide, M. B., George, S., Sole, A., and Hardeberg J. Y. (2023). Standardization of digitized heritage: a review of implementations of 3D in cultural heritage. *Heritage Science*, Vol. 11, p. 249. DOI: 10.1186/s40494-023-01079-z.
- Sullivan, G. M. and Artino, A. R. (2013). Analyzing and interpreting data from likert-type scales, *Journal of Graduate Medical Education*, Vol. 5, Issue 4, pp. 541–542. DOI: 10.4300/jgme-5-4-18.
- Wang, X., Luo, L., Chen, F., Wan, H., Yang, R., and Zhen, J. (2020). Digital Heritage. In Guo, H., Goodchild, M. F., and Annoni, A. (eds) (eds) *Manual of Digital Earth*. Springer, Singapore, pp. 565–591. DOI: 10.1007/978-981-32-9915-3\_17.
- Younus, I., Al-Hinkawi, W., and Lafta, S. (2023). The role of historic building information modeling in the cultural resistance of liberated city. *Ain Shams Engineering Journal*, Vol. 14, Issue 10, p. 102191. DOI: 10.1016/j.asej.2023.102191.

## РОЛЬ ВИРТУАЛЬНОЙ ДОКУМЕНТАЦИИ В РЕФОРМИРОВАНИИ НАСЛЕДИЯ ГОРОДА БАСРЫ

Рийям Раджаб Фенджан\*, Хала Абдулкарем Абдулгани Альсамер, Нур Абдуламир Абд Фли Альмансур

Университет Басры, г. Басра, Ирак

\*E-mail: riyam.rajab@uobasrah.edu.iq

### Аннотация

**Введение.** Технология документирования виртуальной реальности может помочь городским дизайнерам и архитекторам изменить форму зданий, являющихся объектами культурного наследия, особенно в городе Басра. **Цель исследования.** Представить технологический потенциал технологий виртуальной реальности (VR), позволяющий оживить эти здания. **Методы.** Теоретический анализ соответствующих исследований, касающихся документации виртуальной реальности и ее технологий. В качестве примера для исследования было выбрано здание старого суда Басры. Также были подготовлены две анкеты, которые были распространены в Интернете, включая ссылку на платформу виртуального наследия (VHP). Первая анкета была направлена двадцати архитекторам и городским дизайнерам, выбранных методом случайного отбора, чтобы определить соответствующую политику сохранения для данного примера в зависимости от их профессионального мнения. Другая анкета была направлена 157 жителям для подтверждения результатов. Кроме того, в качестве инструментов цифровой документации для документирования тематического исследования использовались программы AutoCAD и Revit, в результате чего были созданы две VR-модели, представляющие две политики сохранения природы (традиционную и эволюционную). **Анализ данных** показал, что эксперты и жители предпочли VR-модель № 1 здания, сохраняющего свой первоначальный вид без дополнений. **Заключение.** Такой подход позволяет изучить выбранную стратегию сохранения объекта наследия еще до стадии реализации.

**Ключевые слова:** документация виртуальной реальности (VRd); объекты культурного наследия; виртуальное наследие; моделирование реального процесса; эволюционное моделирование.

# DEVELOPMENT OF FLOOD-RESISTANT ARCHITECTURAL DESIGN PROPOSALS ON AMASYA YALIBOYU HOUSE AND ITS SURROUNDING

Ozge Kartal<sup>1\*</sup>, Asena Soyluk<sup>2</sup>, Zerrin Funda Urük<sup>3</sup>

<sup>1</sup>Gazi University Graduate School of Natural and Applied Sciences, Ankara, Turkey

<sup>2</sup>Gazi University, Ankara, Turkey

<sup>3</sup>İstanbul Gedik University, İstanbul, Turkey

\*Corresponding author's email: krtl.ozgee@gmail.com

## Abstract

**Introduction:** Calamities, which are characterised as natural disasters, constitute a major problem on a global scale in terms of causing loss of both life and property. Although disaster risk reduction activities have been carried out in many countries, they still cause great losses. Turkey, as a country where many natural disasters have occurred and large-scale damages have occurred, still has problems in disaster management. **The purpose of the study:** The study aims to develop architectural design proposals to prevent a possible flood disaster in the context of the historic Yaliboyu house in Amasya, Turkey, in accordance with the principles outlined by FEMA and other organizations. While presenting the proposals, the height of the flood waters and the cultural characteristics of the historical texture were taken into consideration and it was tried not to damage the historical texture. **Material and Method:** In the flood-resistant building design, the principles of organizations such as FEMA, DSI, and AFAD were investigated, design solutions based on the acquired data were discussed in detail through an important historical structure and its surroundings located in the city of Amasya, Turkey. **Results:** The city of Amasya, located in the north of the country, has struggled with many natural disasters and suffered losses in the past. According to the 50, 100 and 500 year recurrence flood hydrograph, major floods are predicted to occur in the city. Considering that these floods may cause loss of life and property, it is important to take architectural measures and especially Yaliboyu houses, which stand out with their historical texture, under protection. In this historical texture, which is in direct contact with the Yeşilirmak River, suggestions were the first presented in the context of the building environment, and then architectural solutions were gradually developed based on the rise of flood waters at the building scale. Recreation areas that can form reservoirs and basins for undefined and empty areas, permeable materials for vehicular and pedestrian paths, raising the lower level of windows for buildings without high entrances and the use of barriers for doors are proposed for the building surroundings. At the building scale, measures were taken at the first stage by providing permeability with green walls with drainage systems at the points of the first contact with flood waters. In the following stages, flood barriers, flood-resistant building materials, basement fill and flood openings were used to prevent the contact of flood waters with the building. At the same time, it is possible to achieve environmental and economic gains with the rainwater collection system proposal. **Conclusion:** The proposed solutions have been a precaution against the predicted flood risk by not disturbing the texture reflecting the history of the city. Especially in order to prevent historical buildings from being affected by disasters, evaluations should be made on the basis of each disaster and solution proposals should be presented to the municipality and administrative authorities by the relevant professional groups and implementation should be started.

**Keywords:** disaster; flood; architectural design.

## Introduction

The rapid increase in the number of natural disasters and the large losses caused by them cause large-scale damages to both building areas and infrastructure. Especially in underdeveloped and developing countries, loss of life and property is higher and economic collapse is experienced. In developed countries, rules for minimising and preventing disaster damages are widely applied. Although the loss of life is less in these countries compared to other countries, the economic losses caused by disasters can be very high (Akın, 2018). Natural disasters and the losses they cause have not only technical but also social and economic dimensions. On a personal basis, lack of awareness,

lack of importance to safety, avoiding additional costs due to economic reasons, lack of sensitivity of the architect and engineer designing the building, lack of safety concerns, ignorance and lack of education of the master constructing the building are other problems (Genç, 2007). The destructions caused by disasters do not only affect the country where the disaster occurred or the nearby geography, but can also create negative results on a global scale. For this reason, transboundary effects of disasters have been emphasised in recent years and for this reason, they are handled in regional and global context. Today, disaster strategies and policies are being implemented in many countries and the concept of risk reduction is being addressed.

In Turkey, the disaster management system and the importance given to disasters changed after the 1999 earthquake (Akin, 2018).

Being prepared and reducing possible damages in the struggle against disasters has become the priority policy of today's world and Turkey's. For this purpose, firstly, current situation analyses should be made and then integrated disaster risk elements should be determined and both the elements to be considered while building new construction areas and structures should be determined and the improvement policies to be made over the current situation should be decided (Altuntaş, 2023).

Droughts, floods and similar disasters as an integral part of nature since time immemorial, It causes continuous and significant loss of life and property. Soils are being used more intensively with unfavourable agricultural methods, forests and pastures are being destroyed, and under all these conditions, floods and flood disasters are becoming more and more frequent (Yaşar Korkanç and Korkanç, 2006). Flood is a natural hazard that easily turns into a disaster and causes great loss of property and life in Turkey as in almost every part of the world. The occurrence, magnitude and extent of damages caused by floods are directly related to the climatological-meteorological, geological-geomorphological, biological characteristics and various activities of people (Ozcan, 2006).

In order to minimize the negative effects of disasters and emergencies, various qualified studies should be carried out before the disasters (Sarı, 2022). Organizations such as FEMA (Federal Emergency Management Agency) in the United States, DSİ (Türkiye State Hydraulic Works) and AFAD (Türkiye Disaster and Emergency Management Presidency) in Turkey carry out many

studies for measures to be taken against floods and other disasters and post-disaster recovery plans. FEMA emphasizes disaster sensitivity by stating that one of its main goals is to prevent and reduce losses from natural hazards (FEMA, 2013). AFAD, on the other hand, states that until recent years, crisis management-oriented studies and investments have been predominant in Turkey, and that response to disasters and subsequent recovery efforts have been at the forefront (AFAD, 2021). In the Yeşilırmak Basin Flood Management Plan prepared by DSİ, disaster management is defined as all of the analysis, planning, decision-making and evaluation processes that organize existing resources for the purposes of preparedness, mitigation, response and recovery against all kinds of hazards that may be caused by floods (DSİ, 2015).

Within the scope of the study; in line with the data obtained as a result of AFAD and DSİ studies, the flood disaster, which can cause a great deal of damage but can be prevented with the measures that can be taken, is examined through the Yalıboyu houses of Amasya province. After discussing the general characteristics of the city, architectural design proposals are presented on the historical building and its surroundings, which have the common characteristics of the historical buildings in the study area, in a way that does not harm the originality of the historical texture of the building. The recommendations were developed based on the studies of FEMA and other organizations on the flood disaster.

#### *The Disaster Susceptibility of Amasya*

Amasya province is located in the northern part of Turkey (Fig. 1), in the central part of the Black Sea region, between 34° 57'–36° 31' east longitude and 41° 04'–40° 16' north latitude (Türkoğlu, 2006). Located in the Yeşilırmak basin, the main branches



Fig. 1. Location of Amasya province in Turkey (Google Earth)

of Yeşilirmak pass through the center of the city. In addition, since it is surrounded by high mountains, the surface shapes are rugged and the city center is in a narrow area (Ateş, 2019).

Since Amasya is located in the Yeşilirmak basin, the waters carried by the tributaries of Yeşilirmak have caused floods due to climatic reasons in the past years (AFAD, 2021). In the Yeşilirmak Basin Flood Management Plan reported by DSİ (Türkiye State Hydraulic Works), two-dimensional hydraulic modeling was carried out in the flood-prone areas and the spreading area, water depth and water velocity corresponding to different recurrence flows were calculated. Three flood scenarios were simulated using 1D/2D models. Based on the hydrological model analysis, iterative hydrographs of Q50, Q100, Q500 were obtained (Fig. 2). Based on these hydrographs, flood hazard map was created. For the 50-year recurrence flood, no flood occurs in Amasya. For the 100-year recurrence flood, some flooding occurs upstream of the province. The depth of the flood reaches 1 to 1.5 metres and covers 5.3 hectares. For the 500-year recurrence flood, a serious flooding event occurs in the upstream part of the province as well as outside the city in the

upstream direction. The flood depth is 2 metres and covers an area of 194 hectares (DSİ, 2015).

It is thought that climate change causes an increase in the number and severity of disasters and this increase will continue in the future. Experts emphasizing the importance of keeping global warming below 1.5 °C until 2030 think that otherwise the disasters experienced today will be much more effective (Gökmen Erdoğan, 2022).

In Amasya, the highest amount of precipitation falls in the spring season and the total annual precipitation is 461.6 mm. The highest precipitation is in May with 53.8 mm and the lowest precipitation is in August with 10.1 mm (Fig. 3). In terms of flood risk, April, May and December can be classified as very risky; January, March and November as risky; July and August as less risky. It should be taken into consideration that the risk of flooding may be at a high level especially in very risky months and precautions should be increased in these months.

#### Case Study

Yalıboyu houses in Hatuniye neighborhood of Amasya, which are under risk in the 100-year and 500-year recurrent flood report, were selected as the work area (Fig. 4). Yalıboyu houses, which stand out

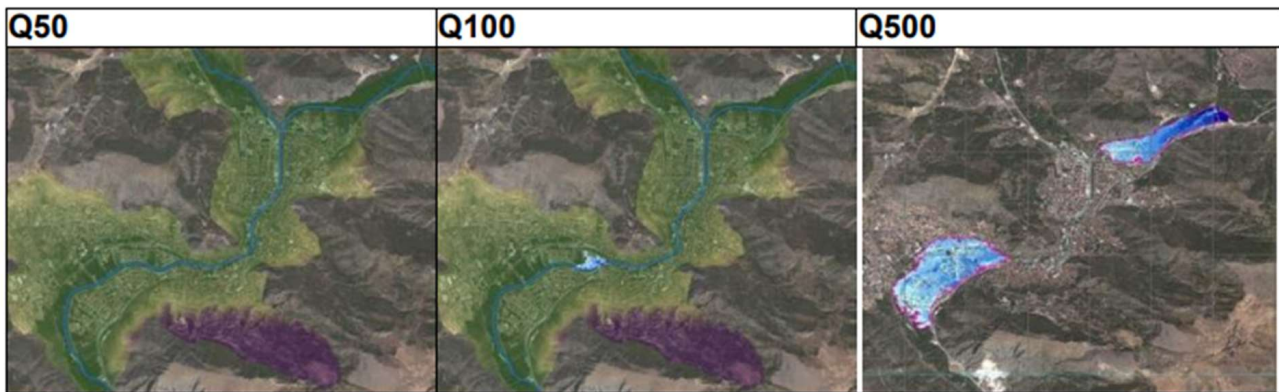

Fig. 2. View of flood hazard maps for Amasya for 50,100, 500 year recurrence periods (DSİ, 2015)

AMASYA	Jan	Feb	Mar	Apr	May	Jun	Jul	Aug	Sep	Oct	Nov	Dec
Measurement Period (1961-2022)												
Average Temperature (°C)	2.6	4.5	8.3	13.4	17.6	21.3	23.8	23.9	20.0	14.6	8.5	4.6
Average Maximum Temperature (°C)	7.0	9.8	14.5	20.4	25.1	28.7	31.1	31.5	27.9	21.9	14.6	8.8
Average Minimum Temperature (°C)	-0.8	0.3	3.1	7.2	11.1	14.5	16.7	16.7	13.0	8.7	3.9	1.3
Average Sunshine Duration (hours)	2.2	3.3	4.5	6.0	7.4	8.8	9.6	9.2	7.5	5.0	3.4	2.1
Average Number of Rainy Days	12.34	11.08	12.48	12.02	12.98	9.05	3.27	2.66	4.74	7.92	9.16	12.56
Average Monthly Total Rainfall (mm)	51.1	37.2	48.1	53.4	53.8	40.1	16.2	10.1	19.7	34.5	42.7	54.7
Measurement Period (1961-2022)												
Maximum Temperature (°C)	23.5	24.8	31.2	35.8	37.9	41.8	45.0	42.2	43.5	36.0	29.7	22.9
Minimum Temperature (°C)	-21.0	-20.4	-15.5	-5.1	-0.1	4.8	8.5	8.8	3.0	-2.9	-9.5	-12.7

Fig. 3. Long-term average monthly precipitation table of Amasya (General Directorate of Meteorology)



Fig. 4. Study area and its surrounding (Türkoğlu, 2006)

with their traditional texture, are located in the north of Yeşilirmak. The mountains rising behind the river, castle ruins and king rock tombs have formed the remarkable texture of the region. Another historical building in the region is the Alçak Bridge. The bridge provided a connection between the river and the opposite part of the city (Ateş, 2019).

Although the architecture destroyed by disasters in Amasya province has been replaced by new buildings, traces of traditional architecture can be seen intensely. One of the most unique examples of traditional civil architecture is Yalıboyu Houses. Yalıboyu is the residential area between the Station Bridge and the Government Bridge, north of Yeşilirmak. There are homogenously many Local Amasya Houses in the region (Güzelci, 2012).

#### *Flood Resistant Design Proposals for the Built Environment*

Most of the buildings in the region are located parallel to the river. Therefore, they were built in adjacent order (Ateş, 2019). Apart from the building areas, there are green areas, playgrounds, empty building parcels, empty undefined areas, roads and squares (Türkoğlu, 2006). For a flood-resilient urban planning, recreational areas are proposed to be used as regulatory reservoirs in undefined and vacant lands and as basins in case of flooding (Fig. 5).

Recreation areas can be designed as basins where water can accumulate at certain points in city centers to drain flood waters and be used when needed. The storage of flood waters in various forms in reservoirs on their way to the receiver can be used today as one of the most comprehensive protection measures of flood regulation effects that reduce flood water flow rate, width of flooded area, timing, etc. (Kadioğlu, 2019).

Although the study area is not within the main transportation axes, the transportation flow is intense (Ateş, 2019). There are three types of road typologies: the first degree vehicle roads, the second degree vehicle roads and pedestrian roads. Although Ziya Paşa Boulevard, which is the first-

degree road, is wide, it cannot meet the traffic load of the area and traffic congestion is experienced. On the second-degree roads, there is no ease of transportation due to the narrowness of the roads. At the same time, narrow sidewalks create insecurity for pedestrians. In case of a possible flood, roads pose a threat as they increase the flow rate of water.

The lack of water-permeable soil and materials makes cities particularly vulnerable to floods that can occur very quickly and at a point scale (Kadioğlu, 2019). In the field of study, use of permeable materials is recommended for both vehicular and pedestrian roads. Flood resistance at the urban scale can be provided with permeable asphalt (Fig. 6, c) on the primary vehicular road, permeable stone (Fig. 6, a) on the secondary vehicular road to integrate with the historical texture, and permeable stone (Fig. 6, d) on the pedestrian road to incorporate the green texture. At the same time, the inadequacy of manhole covers used in all transportation arteries makes it difficult to drain flood waters. Super or combined manhole covers can be used to prevent this problem (Fig. 6, b).

The majority of Yalıboyu Houses in the study area have basement floors. Basements are one of the first areas to be penetrated by flood waters in case of a possible flood. Therefore, the measures to be taken on the basement floor surfaces are important in terms of flood resistant design principles.

Flood protection measures can be taken by raising basement windows above the base water level (Fig. 7, b) determined by at least 100-year flood waters. Similarly, a waterproof cover (Fig. 7, a) can be installed on the door of buildings with zero entrance or entrance below the base water level to prevent the building from being flooded to a great extent (Kadioğlu, 2019).

Within the scope of the study, the building in Hatuniye Neighborhood, which has the characteristics of Amasya Yalıboyu Houses and which is thought to be the first to be affected in case of a possible

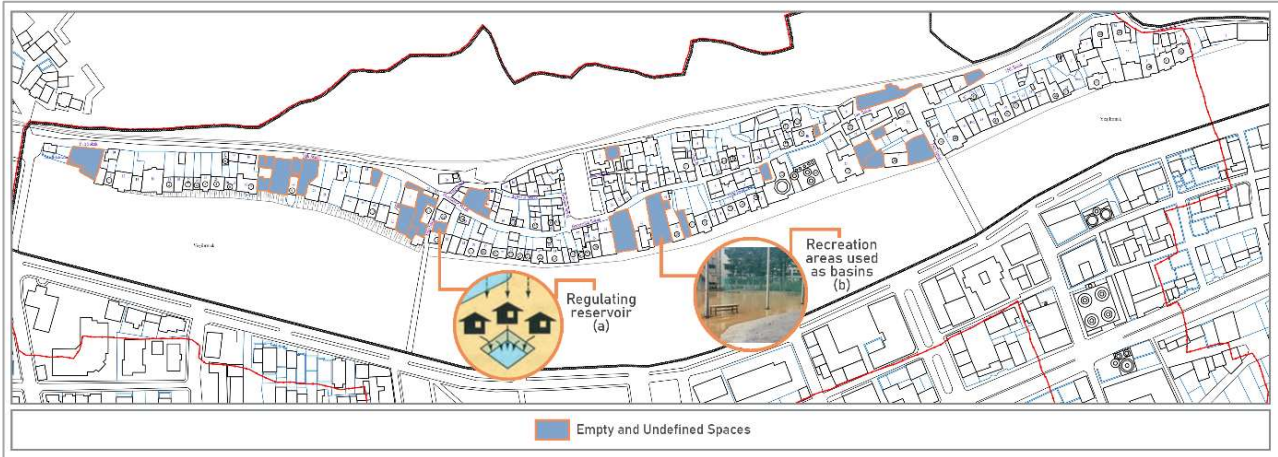

Fig. 5. Empty and undefined spaces — design proposals (Türkoğlu, 2006) (Edited by authors):  
a —Regulating reservoir (Kadioğlu, 2019); b — Recreation areas used as basins (Ikeuchi, 2012)

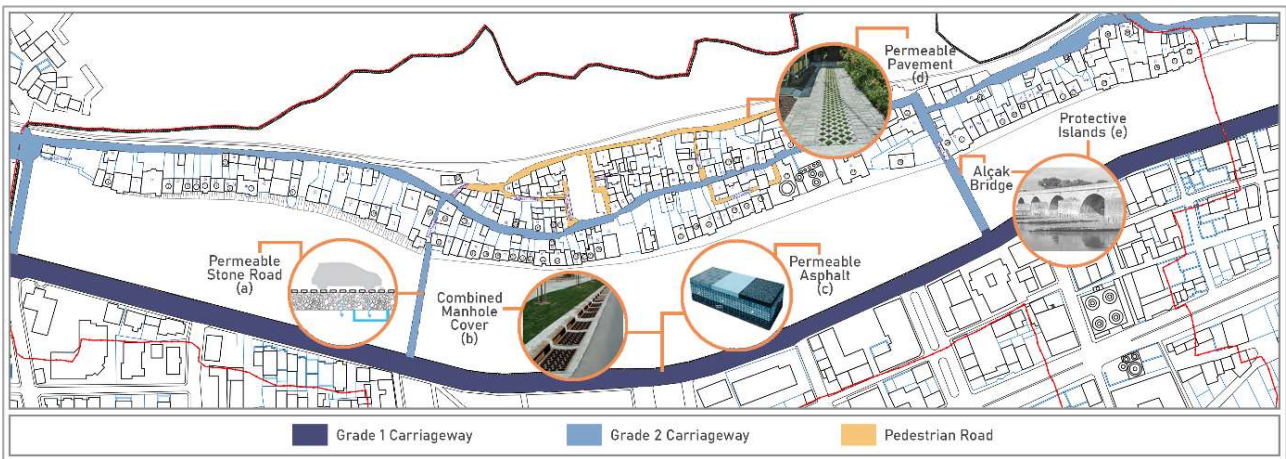

Fig. 6. Transportation arteries-Design proposals (Türkoğlu, 2006) (Edited by authors) [a Permeable stone road (Al, 2018), b) Combined manhole cover (Kadioğlu, 2019), c) Permeable asphalt (Philadelphia Water Department), d) Permeable pavement (Al, 2018)]

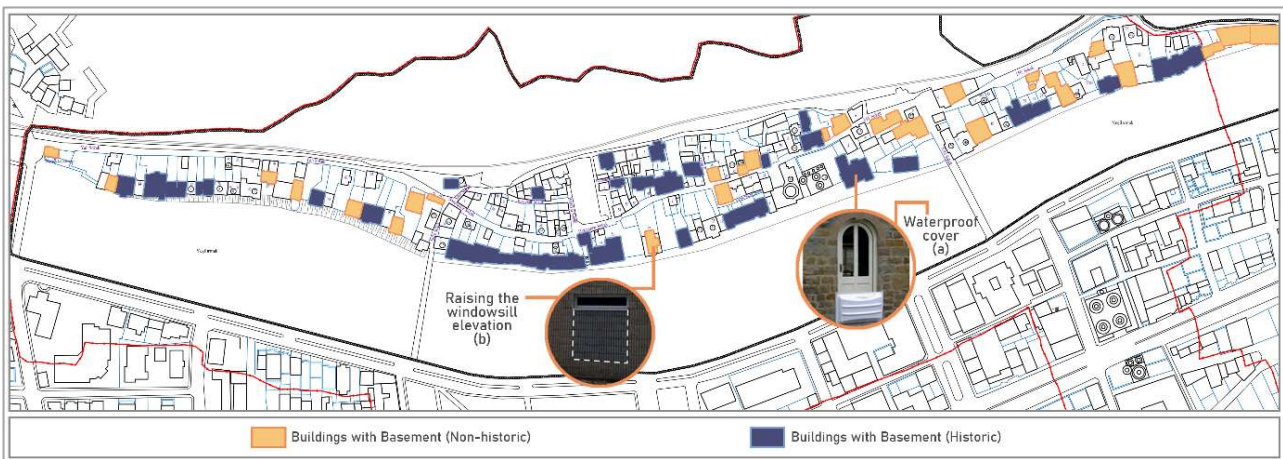

Fig. 7. Buildings with basements and zero entrance — Design proposals (Türkoğlu, 2006) (Edited by authors): a — Waterproof cover (Kadioğlu, 2019); b — Raising the windowsill elevation (Kadioğlu, 2019)

flood, was selected (Fig. 8). The selected building is functionalized as a boutique hotel-museum. Hatuniye Mosque and the building functioning as a restaurant are located in the neighborhood of the building. At the same time, the Kral Kaya Tombs are located behind it.

The studied building (Fig. 9, a) is a traditional building on the historical city wall on the edge of Yeşilirmak, which is arranged as two floors over the basement (Fig. 9, b). The building is arranged with mudbrick filling between wooden roofs and is used as a museum-house today. The north and west facades of the building protrude outwards and provide mobility in the building. Guillotine windows are seen in groups of three on all facades except the east facade. The building, organized in the Haremlik-Selamlık style, was built in the plan type of a central room (Yüce, 2001).

**Flood Resistant Design Proposals at Building Scale**

The study area is located adjacent to Yeşilirmak. It is one of the areas that may experience the greatest impact in a possible flood disaster. When the area analyses are examined, there are negativities such as excessive building stock, narrow streets, inadequacy of the drainage system. These were also taken into consideration when proposals were made at the building scale. The historical building with 2 floors and a basement, which has the characteristics of Yalıboyu Houses and which is functioned as a boutique hotel-museum with a lower elevation compared to other buildings, was selected as the building to be proposed. Architectural measures that can be taken against flooding in the building are discussed in line with

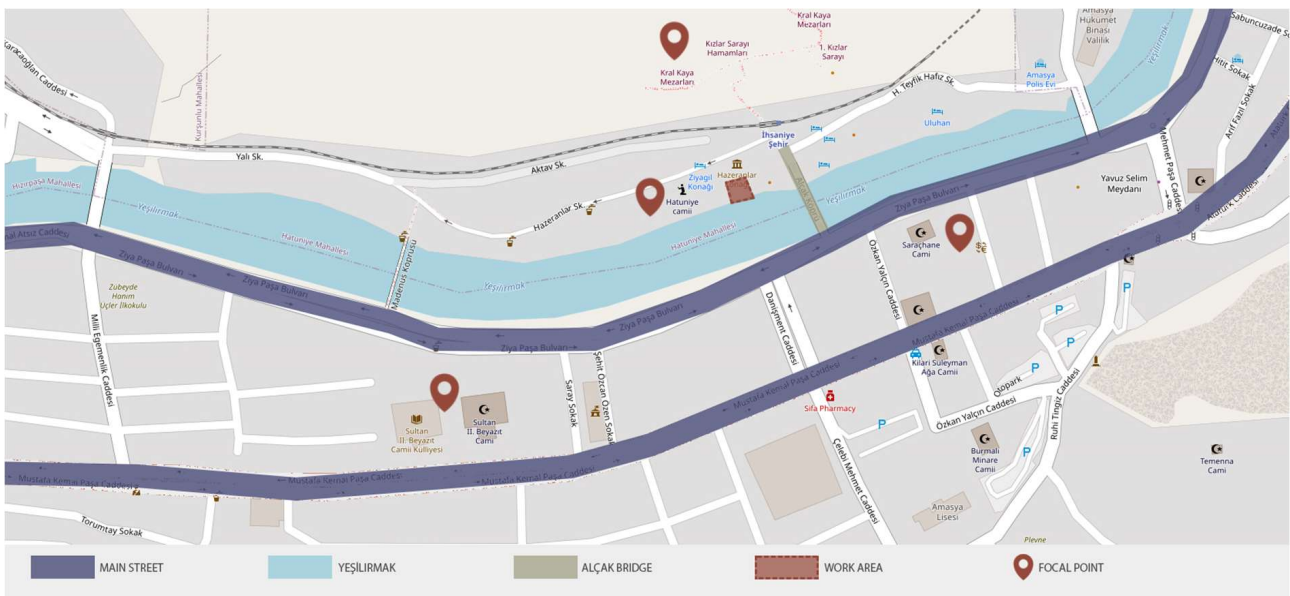

Fig. 8. The building and its surroundings (Google Earth) (Edited by authors)

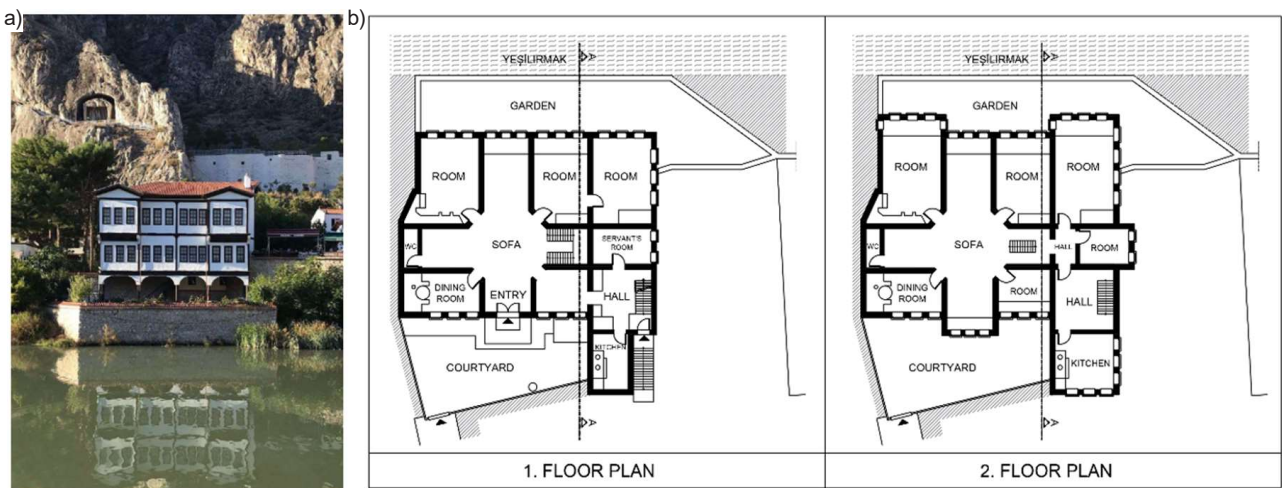

Fig. 9. Studied building (a) (Author archive) and floor plans (b) (Ministry of Culture and Tourism, 2021) (Edited by authors)



the principles adopted by organizations such as FEMA (Federal Emergency Management Agency), DSI (Turkiye State Hydraulic Works) and AFAD (Turkiye Disaster and Emergency Management Presidency). The proposals have been developed with the aim of preserving the historical texture with aesthetic concerns.

### *Stage 1: Green Wall Design and Evacuation Drainage*

Planting of building surfaces makes significant contributions to urban ecology due to its functions such as protecting buildings, providing climatic comfort, improving environmental conditions and reducing some environmental problems, as well as aesthetic and visual contributions at both urban and single building scales. It also provides benefits by collecting possible flood waters and conveying them to the drainage channel (Tokatlı, 2021).

In the situation that the flood waters rise more than 1 metre on the courtyard wall located on the façade of the building facing Yeşilirmak, it is recommended to design a green wall in the first stage and to make the water permeation by the green wall (Fig. 10). The flood waters can be transferred to the drainage system through the drainage channels of the wall. Although this system is costly in terms of establishment, it is less costly in terms of maintenance. It can also be preferred due to its aesthetic appearance. With this design, flood waters are prevented from overcoming the wall in the first stage.

Large-scale flood disasters can be prevented by building a separate drainage system against flooding (FEMA, 2015). In cases where the capacity of the green wall is exceeded and the flood height exceeds 1.5 metres, it is recommended that the flood waters be conveyed to the sewer via an evacuation

drainage (Fig. 10). The drain used can be activated automatically or manually only in case of flooding.

### *Stage 2: Flood Barrier and Drainage Pump*

Flood barriers that resist high hydrodynamic forces to reduce the threat to people and structures in flood-prone areas are another proposal. Barriers can be temporary and permanent, as well as successively placed in various locations (Rappazzo and Aronica, 2016). In case the flood depth exceeds 2.5 metres, a flood barrier with an opening-closing system made of tempered glass on the wall facing the river is proposed as a precautionary measure (Fig. 11). The proposed flood barrier can be designed to open during the flood and close afterwards. In case the flood waters exceed the flood barrier, it is proposed to collect them in the drainage raceway covered with permeable material in the courtyard and return them to the river with a drainage pump.

### *Stage 3: Flood Resistant Materials*

The risk of damage differs according to the sensitivity of the materials used in the construction system to water and the way they are used in the building (masonry, carcass, etc.). For example, materials such as wood, which absorb water quickly and deteriorate due to the development of harmful organisms if not properly dried in contact with water, and construction systems containing these materials have a higher risk of flood damage (Gökmen Erdoğan and Gül Unal, 2021).

It is recommended to use metal as door material on building surfaces that may be exposed to flood waters. The use of glass block bricks for window openings creates resistance against flooding. In the interior, it is recommended to cover the wall surface with non-paper faced plasterboard. On the floor, terrazzo tiles can be used to prevent flooding (FEMA, 2015). In the event that flood waters enter

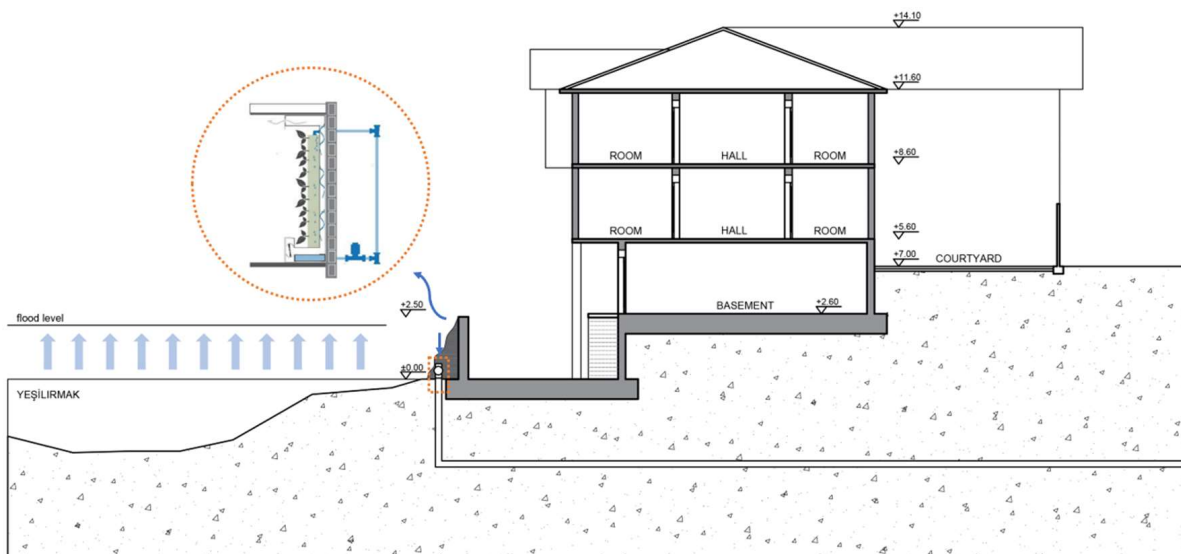

Fig. 10. Green wall design and evacuation drainage (Drawn by the authors)

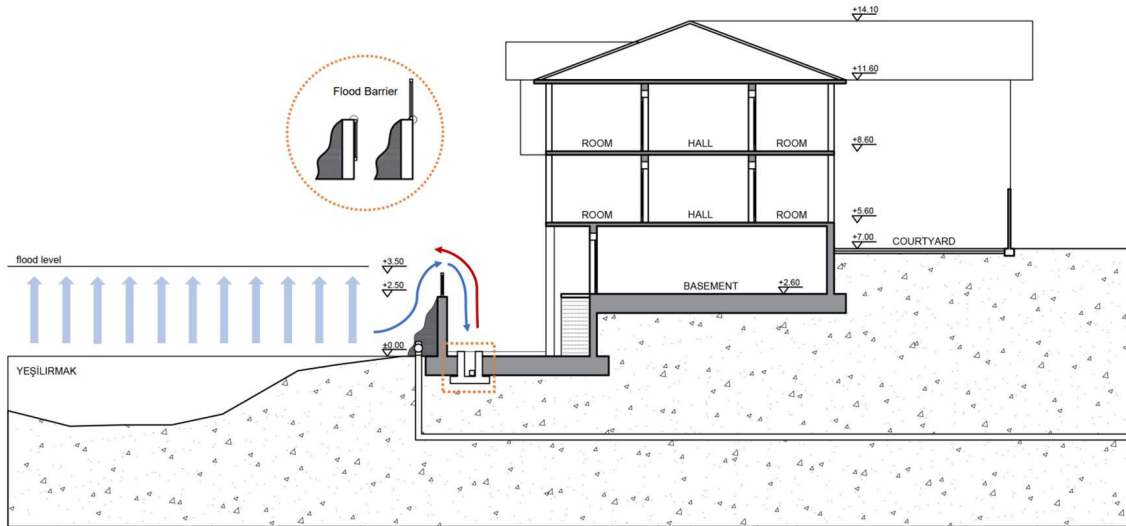

Fig. 11. Flood barrier, drainage raceway and pump (Drawn by the authors)

the garden, the wooden pillars in the courtyard of the building are not resistant to flood waters. It is recommended that these posts be covered with a flood-resistant wood oil or metal sheet. At the same time, it is considered appropriate to use a barrier door at the basement door (Fig. 12).

**State 4: Basement Backfill and Flood Openings**

Floors below the BFE (Base Floor Elevation) level can be filled with construction fill material and the walls above the ground can be reinforced with flood openings. Flood waters can be prevented from entering the structure with automatically opened flood openings placed below the BFE level (FEMA, 2015). In case the flood waters exceed 5 m, it is recommended to cancel the use of the basement floor and fill the courtyard with filling material up to the ground level in order to prevent flood waters from entering the building (Fig. 13). In case of a possible flood, flood openings are proposed to be

constructed in the basement walls above the ground level, and in case of a possible flood, the water is proposed to enter through the flood openings and transfer to the garden without entering the building. In the garden, it is possible to remove the water with evacuation drainage.

**Stage 5: Rainwater Harvesting System**

In today's world where water is important, it is known that only 30 per cent of the rainwater falls into the groundwater and the amount of rainwater that cannot be utilized is very large. Considering that water prices are increasing in line with the importance of water, collecting, storing and utilizing rainwater is both an economic gain in terms of environment and water resources. Nowadays, the use of potable municipal water for irrigation water needs, which reaches significant amounts, is an important problem both environmentally and economically

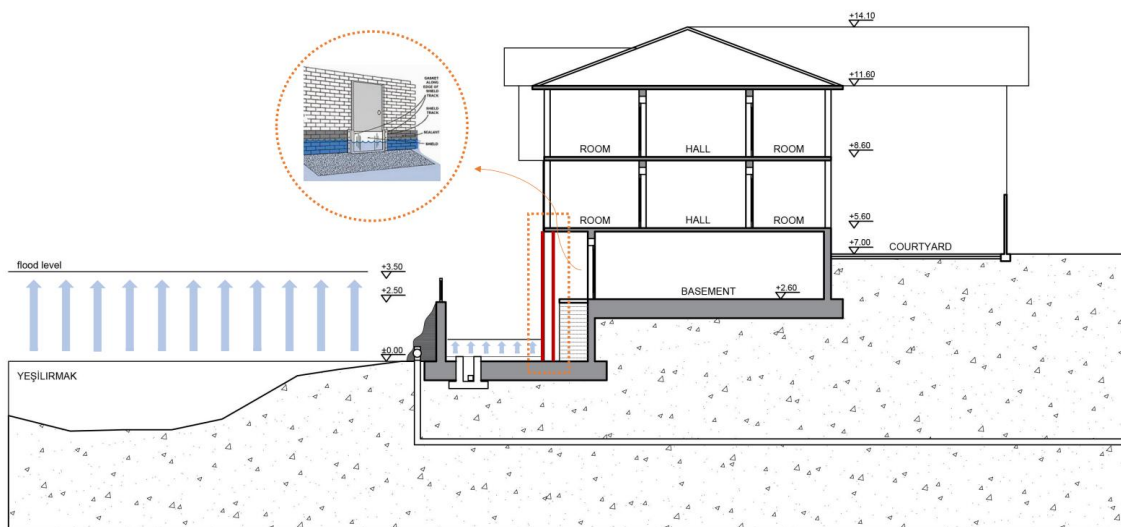

Fig. 12. Coating with flood resistant material (Drawn by the authors)

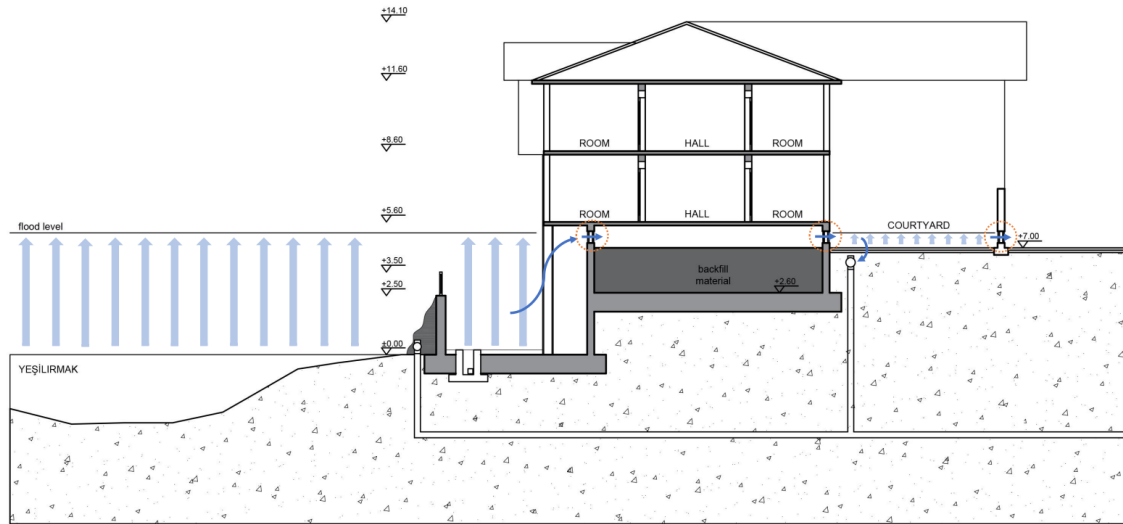

Fig. 13. Basement backfill and flood openings (Drawn by the authors)

(Yalılı Kılıç and Abus, 2018). A rainwater harvesting system is a method of collecting rainwater and storing this free rainwater in a tank before reusing it for a specific purpose. This system is widely used in most regions of the world that are suitable for local climatic conditions. Rainwater harvesting is typically used for domestic use, agriculture and environmental management. Rainwater harvesting to provide water for domestic purposes is a common practice in developing countries, especially in arid and semi-arid regions affected by water scarcity, but also in urban areas (Temizkan and Tuna Kayılı, 2021). This system is also proposed for the studied building against the drought, which shows its effect more and more every day. By installing a rainwater storage system in the cancelled basement floor, environmental and economic gains are achieved (Fig. 14). At the same time, it contributes to the

re-functionalization of the vacated basement floor. Although the system is expensive in our country, it is important in terms of usefulness.

#### Evaluation

Within the scope of the study, Yalıboyu houses representing the traditional fabric of Amasya were analyzed and architectural design proposals were presented through the building and its surroundings (Table 1). Basins (recreation areas) and reservoirs were designed in undefined areas to be used in case of possible flooding in the city, aiming to control flood waters. Based on the intensity of use and location of the transportation arteries in the study area, design proposals were presented to resist flooding. Permeable asphalt is proposed for the first level vehicular road, permeable stone for the second level vehicular road and permeable stone material for the pedestrian road. At the same time, manhole covers

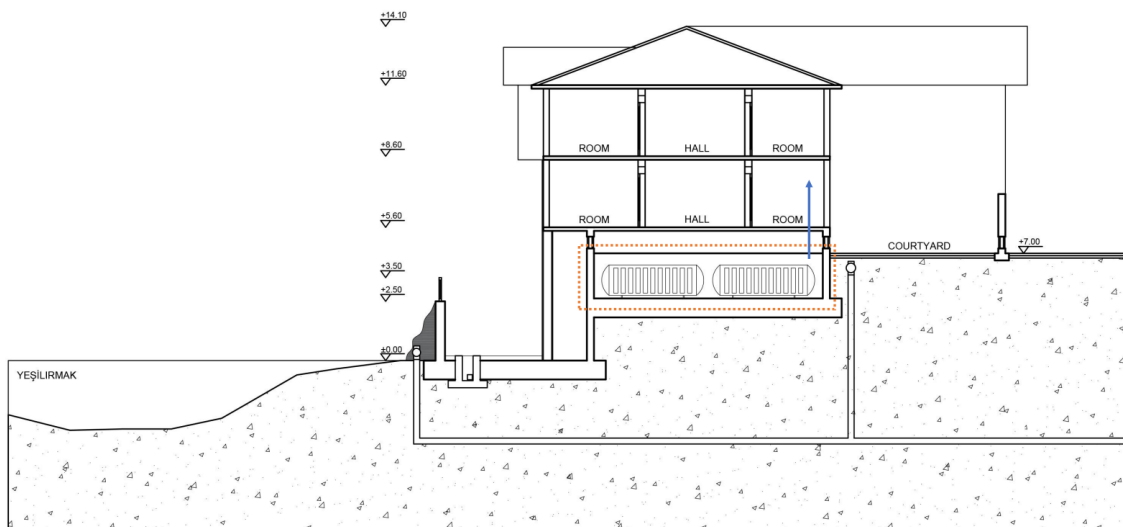

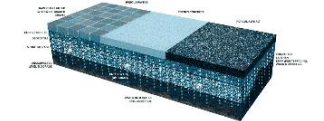
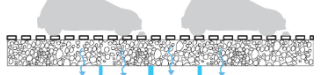





Fig. 14. Rainwater harvesting system (Drawn by the authors)

Table 1. Proposals against flooding for the building surroundings

FIELDS	ISSUE	SOLUTION PROPOSAL	SOLUTION PROPOSAL IMAGE
Empty and Undefined Spaces	Inadequacy of flood water storage areas	Recreation areas used as basins	 <p>See Figure 5 (b) (Ikeuchi, 2012)</p>
		Regulating reservoir	 <p>See Figure 5 (a) (Kadioğlu, 2019)</p>
Transportation Arteries	Not using water-permeable materials	Permeable asphalt	 <p>See Figure 6 (c) (Philadelphia Water Department)</p>
		Permeable stone road	 <p>See Figure 6 (a) (AI, 2018)</p>
		Permeable pavement	 <p>See Figure 6 (d) (AI, 2018)</p>
	Inadequate manhole	Combined manhole cover	 <p>See Figure 6 (b) (Kadioğlu, 2019)</p>
Buildings with Basements and Zero Entrance	Doors and windows below the flood water level	Waterproof cover	 <p>See Figure 7 (a) (Kadioğlu, 2019)</p>
		Raising the windowsill elevation	 <p>See Figure 7 (b) (Kadioğlu, 2019)</p>

were found to be inadequate in all transportation networks and super or combined manhole covers were proposed as a solution to this problem. Another problem in the area is that most of the historic buildings have basements or no raised entrances. As a solution to this problem, it is suggested that the lower elevation of the window be raised above the base water level determined by at least 100 years

of flood waters. For the doors, flood resistance with barriers was considered.

In the second stage of the study, flood resistant design proposals were presented based on the flood level (Table 2) on the building that has the common characteristics of Yalıboyu Houses. Yalıboyu houses, which attract attention with their historical texture, are located in a neighbouring

**Table 2. Solution proposals against flooding**

	<b>Flood Level</b>	<b>Proposal</b>
<b>Stage 1</b>	1–1.5 m	Green Wall Design and Evacuation Drainage
<b>Stage 2</b>	1.5–2.5 m	Evacuation Drainage
<b>Stage 3</b>	> 2.5 m	Flood Barrier and Drainage Pump
<b>Stage 4</b>	0–5 m (inside the courtyard)	Flood Resistant Materials
<b>Stage 5</b>	> 5 m	Basement Backfill and Flood Openings
<b>Stage 6</b>	–	Rainwater Harvesting System

location to Yeşilirmak and are the building group that may be affected in case of a possible flood. The high density of buildings, narrow streets and inadequacy of the drainage system increase the extent of the disaster.

In line with the principles adopted by FEMA (Federal Emergency Management Agency) and other organizations in the historical building, which has the characteristics of Yalıboyu Houses and whose elevation is lower than the other buildings, it is proposed that in the event that the flood level exceeds 1 meter, the flood waters should be transmitted to the drainage system with the green wall system and transferred to the drainage system with the drainage channels of the system. With this system, flooding can be prevented at the first stage and aesthetically integrated into the historical structure. The drainage system, which can be activated automatically or manually in case the flood level exceeds 1.5 meters, is also proposed considering the exceeding capacity of the green wall. In the second stage, in case the flood level exceeds 2.5 metres, a flood barrier made of tempered glass with an opening-closing mechanism is proposed on the garden wall that interacts with the river. With this system, the historical texture is not damaged and glass material which is thought to be compatible is used. In case the flood waters exceed the barrier, a drainage raceway covered with permeable material and a drainage pump that returns the water collected in this channel to the river is proposed in the garden. The majority of the building is made of wood, which absorbs water quickly and deteriorates in contact with water. Considering the risk of contact with the building elements in case the flood waters rise up to 5 metres above the garden floor, in the third stage; it is proposed to cover the wooden posts in the garden with wood oil or metal sheet. For the wooden basement door, use of a barrier door was deemed appropriate. As the fourth stage, in case the flood level exceeds 5 meters, it is deemed appropriate to cancel the basement floor and fill it with filling material up to the courtyard floor in order to prevent flood waters from entering the building. Flood openings are designed in the basement walls above the ground level, and in case of a possible flood, it is proposed to transfer the water to the

garden through the flood openings without entering the building. It is possible to use a drainage system for the water accumulated in the garden. Finally, a rainwater harvesting system is proposed in the basement floor, which was cancelled in response to the drought disaster, which is becoming more and more effective every day in the world and in Turkey. Thus, the basement floor has been functionalized and a rainwater storage system has been installed to provide environmental and economic gains. With all these proposals, aesthetic and practical solutions are offered against possible flood disasters.

#### **Conclusion**

Natural disasters, which cause major structural damages in settlements and infrastructures, cause economic collapse as well as loss of life and property. The destructions caused by disasters can cover not only the geography where they occur, but also the surrounding geographies and cause disasters on a global scale. One of the disasters that have caused many losses from past to present is flood disaster. Many negativities such as unconscious use of agricultural lands, human errors, destruction of forests have brought flood and flood disasters. Floods can occur almost anywhere in the world, but the probability of occurrence in Turkey is very high, especially with the effect of drought and global warming. Amasya, which has experienced and is likely to experience many flood disasters in the past, has been examined within the scope of the study.

Amasya stands out with its topographical aspect and historical process. Flooding is seen as a major threat when the disaster situation is considered. In the past years, many flood disasters have occurred with the overflow of Yeşilirmak basin, causing loss of life and property. The DSI (Türkiye State Hydraulic Works) report states that flood disasters may occur in Amasya province according to the 50, 100 and 500 year recurring flood hydrograph.

In line with the data obtained, architectural design suggestions that will increase the flood resistance of the buildings are presented through Yalıboyu House and its surroundings. While presenting the proposals, the building stock, historical texture and geographical features in the study area were taken into consideration. Many

buildings in the study area are historical buildings and have common characteristics with the building in the studied area. For this reason; the proposals are important not only for a single building, but also for other buildings in the area and their applicability is considered high.

In the studies conducted by FEMA and other organizations, there are different flood-resistant building design principles and proposals in different countries. While examining the

measures to be taken against flood disasters, the structure and geographical characteristics of the city to be applied should be well analyzed and appropriate proposals should be developed. Evaluations should be made not only from an architectural point of view but also by other professional groups and joint studies should be carried out. The studies should be supported and implemented by municipalities and other administrative authorities.

## References

- AFAD. (2021). Amasya Provincial Risk Reduction Plan. [online] Available at: <https://amasya.afad.gov.tr/kurumlar/amasya.afad/planlar/AMASYAIRAP.pdf>. [Date accessed March 19, 2023].
- Akın, D. (2018). United Nations Funded Studies on Disaster Risk Reduction. Disaster Management in Turkey. *Palme Press*.
- Al, S. (2018). Adapting cities to sea level rise: Green and gray strategies. *Island Press*.
- Altuntaş, D. D. (2023). Determination of Disaster Risk Factors through Architectural Application Project and Details: The Case of Hayriye Neighborhood in Eskisehir Province, *Master's Thesis*, Eskisehir Technical University Graduate School of Education, Eskisehir.
- Ateş, D. G. (2019). Evaluation of the Conversation Practices Applied In Amasya Province on the Basis of the Decisions of the Conversation, *Master's Thesis*, Gazi University Institute of Science and Technology, Ankara.
- DSİ (Türkiye State Water Works). (2015). Yeşilirmak Basin Flood Management Plan. [online] Available at: <https://www.tarimorman.gov.tr/SYGM/Belgeler/havza%20tan%C4%B1t%C4%B1m%2023.03.2023/ingilizce/YESILIRMAK%20RIVER%20BASIN.pdf>. [Date accessed March 19, 2023].
- FEMA. (2013). Action Plan for Performance Based Seismic Design. *CreateSpace Independent Publishing Platform*.
- FEMA. (2015). Reducing Flood Risk to Residential Buildings That Cannot Be Elevated.
- Genç, F. N. (2007). Natural Disasters in Turkey and Risk Management in Natural Disasters, *Journal of Strategic Research*, No. 9, pp. 200–226.
- General Directorate of Meteorology (Türkiye-Amasya) (2024). Seasonal Normals for Amasya Province (1991-2020). [online] Available at: <https://www.mgm.gov.tr/veridegerlendirme/il-ve-ilceler-istatistik.aspx?m=AMASYA> [Date accessed April 27, 2024].
- Google Earth (2024). Location of Amasya in Turkey. [online] Available at: <https://earth.google.com/web/> [Date accessed February 18, 2024].
- Gökmen Erdoğan, B. (2022). A Model Proposal for Risk Management in Increased Floods due to Climate Change Impact and Its Analysis through the Example of Edirne, *Doctoral Thesis*, Yıldız Technical University Institute of Science and Technology, İstanbul.
- Gökmen Erdoğan, B. and Gül Ünal, Z. (2021). A Model Proposal for Flood Risk Analysis of Architectural Heritage: Edirne Bayezid II Complex Flood Risk Analysis. *Megaron*, Vol. 16, Issue 3, pp. 367–384.
- Güzelci, O. Z. (2012). A Shape Grammer Study on Amasya Yaliboyu Houses. *Master's Thesis*, İstanbul Technical University Institute of Science and Technology, İstanbul.
- Ikeuchi, K. (2012). Flood Management in Japan. Water and Disaster Mang. Bureau, MLIT, Japan.
- Kadioğlu, M. (2019). Urban Flood Management and Control Guide. *Union of Marmara Municipalities Culture Publishing*.
- Ozcan, E. (2006). The Floods and Turkey. *Journal of Gazi Faculty of Education*, Vol. 26, Issue 1, pp. 35–50.
- Philadelphia Water Department. Permeable Paving. [online] Available at: <https://water.phila.gov/gsi/tools/permeable-paving/>. [Date accessed March 19, 2023].
- Rappazzo, D. and Aronica, G. T. (2016). Effectiveness and applicability of flood barriers for risk mitigation in flash-flood prone mediterranean area. *E3S Web of Conferences*, Vol. 7, p. 12010. DOI: 10.1051/e3sconf/20160712010.
- Sarı, B. (2022). Analysis of AFAD and FEMA's strategic plans in terms of disaster management and sendai framework. *Emerg Aid Disaster Science*, Vol. 2, Issue 1, pp. 10–18.
- Temizkan, S. and Tuna Kayılı, M. (2021). Determination of Optimum Storage Method in Rainwater Collection Systems: The Case of Karabuk University Social Life Center. *Al-Jazari Journal of Science and Engineering*, Vol. 5, Issue 3, pp. 102–116.
- Tokatlı, S. (2021). Green Facades: A Sample Case Study in Antalya Kemer. *PAUD - Journal of Landscape Practices and Research*, Vol. 3, Issue 1, pp. 28–38.
- Türkoğlu, E. (2006). The Analysis and Evaluation of Amasya, Hatuniye Mahallesi and The Preservation / Rehabilitation Proposals for the Traditional Settlement, *Master's Thesis*, Gazi University Institute of Science and Technology, Ankara.
- Yalılı Kılıç, M. and Abus, M. N. (2018). Rain Water Harvesting in a Garden House Sample. *International Journal of Agriculture and Wildlife Science (IJAWS)*, Vol. 4, Issue 2, pp. 209–215.
- Yaşar Korkanç, S. and Korkanç, M. (2006). Impacts of Floods and Overflows on Human Life. *ZKU Bartın Forest Faculty Journal*, Vol. 8, Issue 9, pp. 42–50.
- Yüce, A. (2001). Amasya Hazeranlar Mansion. *Amasya Culture Publishing*, Ankara.

## РАЗРАБОТКА ПРЕДЛОЖЕНИЙ ПО ПРОТИВОПАВОДКОВОМУ АРХИТЕКТУРНОМУ ПРОЕКТИРОВАНИЮ ДОМА ЯЛИБОЮ В Г. АМАСЬЯ И ЕГО ОКРЕСТНОСТЕЙ

Озге Картал<sup>1\*</sup>, Асена Сойлук<sup>2</sup>, Зеррин Фонда Урюк<sup>3</sup>

<sup>1</sup>Высшая школа естественных и прикладных наук Университета Гази, г. Анкара, Турция

<sup>2</sup>Университет Гази, г. Анкара, Турция

<sup>3</sup>Университет Гедик, г. Стамбул, Турция

\*E-mail: krtl.ozgee@gmail.com

### Аннотация

**Введение.** Катаклизмы, которые характеризуются как стихийные бедствия, представляют собой серьезную проблему в глобальном масштабе, поскольку приводят к человеческим жертвам и материальным потерям. Несмотря на то, что во многих странах проводятся мероприятия по снижению риска стихийных бедствий, они по-прежнему приводят к большим потерям. Турция, как страна, где произошло множество стихийных бедствий и был нанесен крупномасштабный ущерб, все еще испытывает проблемы в управлении стихийными бедствиями.

**Цель исследования:** разработать предложения по архитектурному дизайну для предотвращения возможного наводнения в контексте исторического дома Ялыбою в г. Амасья, Турция, в соответствии с принципами, изложенными FEMA и другими организациями. При разработке предложений учитывались высота паводковых вод и культурные особенности исторической структуры рельефа, при этом старались не повредить историческую структуру. **Материалы и методы.** При проектировании сейсмостойких конструкций были изучены принципы таких организаций, как FEMA, DSI и AFAD, а проектные решения, основанные на полученных данных, были подробно обсуждены на примере важного исторического сооружения и его окрестностей, расположенных в городе Амасья, Турция. **Результаты.** Город Амасья, расположенный на севере страны, в прошлом не раз сталкивался со стихийными бедствиями и нес потери. Согласно временному графику наводнений за периоды 50, 100 и 500 лет, в городе прогнозируются крупные наводнения. Учитывая, что эти наводнения могут привести к человеческим жертвам и материальным потерям, важно принять архитектурные меры и особенно взять под защиту дома Ялыбою, которые выделяются своей исторической фактурой. В этой исторической структуре, которая находится в непосредственном контакте с рекой Ешилъырмак, сначала были представлены предложения в контексте строительной среды, а затем постепенно были разработаны архитектурные решения, основанные на подъеме паводковых вод в масштабе здания. В окрестностях зданий предлагается создать зоны отдыха, которые могут стать резервуарами и бассейнами для неопределенных и пустующих территорий, использовать проницаемые материалы для автомобильных и пешеходных дорожек, поднять нижний уровень окон зданий без высоких входов и использовать барьеры для дверей. В масштабах здания на первом этапе были приняты меры по обеспечению водонепроницаемости с помощью вертикальных садов с дренажными системами в местах первого контакта с паводковыми водами. На последующих этапах для предотвращения контакта паводковых вод со зданием использовались барьеры от наводнений, устойчивые к наводнениям строительные материалы, засыпка подвалов и обустройство проемов от наводнений. В то же время, предлагая систему сбора дождевой воды, можно добиться экологических и экономических преимуществ. **Выводы.** Предложенные решения являются мерой предосторожности против прогнозируемого риска наводнения, не нарушающей структуру, отражающую историю города. Специально для того чтобы исторические здания не пострадали от стихийных бедствий, необходимо проводить оценку каждого стихийного бедствия, представлять предложения по решению проблемы муниципалитету и административным органам соответствующими профессиональными группами и приступать к их реализации.

**Ключевые слова:** стихийное бедствие; наводнение; проектирование зданий.



# ADAPTATION OF VERNACULAR WISDOM IN CONTEMPORARY ARCHITECTURE IN THE HOT-DRY CLIMATE IN THE CONTEXT OF INDIAN SUB-CONTINENT

Kaja Nagaraju\*, Benarjee Sayak

School of Planning and Architecture, Vijayawada, India

\*Corresponding author's email: nagaraju.kaja@spav.ac.in

## Abstract

**Introduction:** Globally there has been a paradigm shift in construction practices towards energy intensive building materials and design practices due to urbanization. Vernacular buildings and traditional knowledge are getting extinct although it has potential for adapting to changes and transforming for the changing needs of urban lifestyle. Some of the architects have tried to capture the principles of vernacular architecture and applied their own understanding in their contemporary designs with the contextual manifestation of the traditional principles for changing times. This type of architecture is known to be neo-vernacular architecture. **The purpose of research** is to see whether vernacular architecture is influencing the contemporary architects in designing sustainable buildings? How this traditional wisdom is getting transformed into a new dimension in a way to cater to the requirements and life style changes of modern times. Further, to know how far this traditional knowledge is successful in meeting the 21<sup>st</sup> century requirements of the people. **Methods:** Traditional architecture of selected buildings in the hot-dry climatic region in India were studied and compared with modern buildings designed using vernacular principles with respect to spatial configuration, form, building materials and passive solar strategies etc. **Results:** The research shown that architects of the modern era have modified the principles of vernacular architecture for it to be used in the modern context for better comfort and to suit to the modern life style of the people giving a new dimension to Vernacular Architecture.

**Keywords:** adaptation; hot-dry climate; neo-vernacular architecture; built environment.

## Introduction

As the World enters the era of urban growth due to globalization and urbanization, there have been rapid changes in the built environment in terms of modernization of materials and construction techniques. It is often noticed that the changes in the built environment are not compatible with its surroundings (Thakkar and Routh, 2019). This depicts a paradigm shift in the construction industry and design practices. Extensive use of high-energy intensive material such as concrete, glass, cement, ceramics, metal etc. combined with the increased amount of construction activity is causing the emission levels of CO<sub>2</sub> gas, which is eventually causing global warming (Lall, 2007). Vernacular architecture of a region is the mirror of the people, place and its culture. The buildings influence the micro-climate around them as much as the micro-climate around the buildings influences the thermal performance of the buildings (Krishan, 1996). As it improves over time as per life style of people, it gets unique characteristics, which are symbiosis with the place and surroundings, and becomes the unique identity of that place and culture. Due to globalization, the identity of the place has been reduced to superficial decoration as foreign materials and technologies have been imported to get the global character (Moor, 2017). With the

changing environment, vernacular architecture has evolved to keep pace with the changing life styles of the people by introducing better equipment and good craftsmanship (Jagatramka et al., 2020). Sustainability has often been an integral part of vernacular architecture as it has been developed for a group of people in a particular region with the available resources, which are limited by natural and economic factors. Yet it was successful in providing viable solutions for human shelter in harsh climatic conditions (Salman, 2018). Taking inspiration from vernacular architecture is a method for solving many environmental problems in urban areas (Martinovic et al., 2023). Few people tried to achieve it with the help of elements, forms and motifs from vernacular architecture. Others tried to find essential principles of vernacular architecture and to adapt them in the modern context in the relevant manner. Involvement of properly schooled architects in the vernacular style of architecture has given birth to a new style of architecture known as "Neo-vernacular architecture". Architect Ashok Lall (2007), has argued that traditionally used construction materials and trades will result in several benefits contrary to the use of industrially manufactured materials. Salman (2018) has discussed that the use of vernacular principles in modern construction can improve identity and sustainability of a space. Architects

Vedamuthu et al. (2014) have discussed adaptive reuse of a vernacular house with an example of old Chettinad house. Cultural adherence, energy efficiency, vernacular influence, coherence with ongoing practices, and harmony with the site and surroundings are the five principles identified for creating neo-vernacular entity as per the study done on Indian neo-vernacular (Rajpu and Tiwari, 2020). Although there have been many studies undertaken to gain wisdom about vernacular architecture of different regions in India, very few only achieved proper implementation of them in modern context. This study aims to discuss about the traditional built forms in the hot-dry climatic region in India, to identify the principles associated in design and construction and how the same principles can be incorporated in the context of contemporary architectural context through suitable examples.

#### *Vernacular architecture: its significance in 21<sup>st</sup> century*

Vernacular architecture, by definition, refers to structures that are locally representative, and regionally differentiated. This concept encompasses the architecture of a precinct as well as a group of people or ethnic group who dwell in a certain geographical place (Olukoya and Atanda, 2020). Therefore, the most common understanding of vernacular architecture is the buildings constructed by the occupant himself or by the community as a group based on local wisdom and traditional knowledge gathered through generations. Thus, vernacular architecture is referred to as "Architecture without architects" to include structures built without any professional intervention and minimum or no use of industrial material of machines (Rudofsky, 1987). Vernacular architecture continues to be associated with past and often perceived as a symbol of poverty and is not being seen as a library of indigenous knowledge so the urge to replace them with modern buildings to portray a progressive image is visible in 21<sup>st</sup> century (Moor, 2017). The ICOMOS charter for built vernacular heritage has explained vernacular architecture as the expression of culture of a community as well as the world's cultural diversity. Architects such as Hasan Fathy, Louis Kahn, B. V. Doshi, Charles Correa, and Raj Rewal also reinterpreted the principles of traditional architecture in their designs. Environmental sustainability as the first pillar of sustainable development focuses on human nature while being concerned about the pressures on the environment in terms of resource consumption, environmental pollution and climate change due to construction activities. Socio-cultural aspects focus on the restoring the cultural values of a community and through built environment reinforce opportunities to flourish and maintain the identity of a place. On the other hand, economic sustainability focuses on safeguarding

and minimizing resource consumption. Therefore, the adaptability aspect of buildings to the changing climatic and social conditions are important with respect to economic sustainability. Simultaneously it also focuses on generation of income for local people or the building occupants (Tipnis, 2012). Vernacular buildings as well as neo-vernacular buildings in recent times are designed and built to satisfy all the aspect of sustainability in most cases. It must be recognised while many of the vernacular principles are sustainable and suitable even today, there are a couple of techniques that are no longer relevant in the context of modern life because of changed culture and ecological conditions. The key challenge in the 21<sup>st</sup> century is to take fundamental lessons from vernacular architecture and to find ways to integrate them for changing lifestyle and climate requirement to design new. Architects shall apply the strategies of vernacular techniques which were proven examples of energy efficient architecture with due consideration to climate (Nagaraju, 2017).

#### **Methodology of the study**

This study has been undertaken in the hot-dry climatic region in India with distinct vernacular architecture. As the first step, some of the traditional buildings with vernacular architectural style from this region have been identified and studied through secondary data from literature and internet sources. Important aspects like the culture, spatial organisation, building form, building materials, construction technique, bioclimatic attributes, and energy efficiency measures, which have been influenced by vernacular architecture, are identified as parameters of the study. As the second part of the study, few contemporary buildings have been identified from the same context which were built based on concepts of vernacular architecture in the modern context, which can become examples of neo-vernacular architecture. These buildings have been studied on the same identified parameters and analysed how the vernacular principles have been transformed and implemented in these contemporary buildings to meet the needs of modern life style with the help of latest technologies in construction.

#### *An overview of the study region*

The climate of India is diversified, with a wide range of weather conditions and varying topography. The Thar Desert throughout the North-West and the Himalayan range in the North work together to create a beautiful landscape and a variety of climate types in India's geography and geology. The Koppen system has classified this region as hot-dry climate where as India has another five climate types as per this classification. Bureau of energy efficiency (BEE), Govt of India has divided the country into 5 distinct climate types as shown in Fig. 1.

For this study, hot-dry climate has been selected which predominantly spread over central

Maharashtra, Eastern half of Gujarat, southern half of Rajasthan and the western border of Madhya Pradesh. The yearly rainfall in this area ranges from 300 to 750 millimetres (15.7–29.5 in). It is prone to dryness because of the South-West monsoon's occasional lateness or failure, which results in less consistent rainfall. March through May are hot and dry, with average monthly temperatures of 32–35 °C, while December, the coldest month, has average monthly temperatures of 14–20 °C. Madhya Pradesh is separated into three distinct regions (Table 1).

The area between the Narmada-Sone River and the Aravalli Mountain range is known as the Middle Highland ("India planted 66 million trees in 12 hours", on 3 July 2017). Burnt clay brick masonry and sandstone slabs are the most commonly used locally available material although locally produced clamp bricks are of bad quality. Wood and locally

fired clay tiles are used for roof construction (DFID report, 2013). The plateau aspect of Maharashtra, which is separated from the Konkan coastline by Ghats, is its most prominent physical feature. The state has a small irrigation area, low natural soil fertility, and huge areas that are prone to drought. ("Western Ghats as world heritage site". The Times of India. 2 July 2012). Teak wood, grey granite, mud, straw, cow dung, burnt clay, sun dried bricks are the common materials available locally for construction (Biswas, 2009).

The Thar Desert and the Aravalli Range, which stretches for more than 850 kilometres from southwest to northeast, practically from one end to the other, are two of Rajasthan's geographical features. The Northwest portion is sandy and barren, with little water, although it gradually improves from desert territory in the extreme west and northwest to a more fruitful and habitable area in the east. Mud, thatch, red/pink/yellow sand stone, limestone, lime, brick and cement blocks are most used material in this part of the country (Rathore et al., 2018). While the sea surrounds the state of Gujarat from the far South to the far North of the Peninsula, the state is primarily flat territory with low hills or minor mountains stretching from Rajasthan, Madhya Pradesh and Maharashtra. The state includes the Kutch region, which includes the Rann of Kutch, a significant tract of land (The Hindu World, Walker). Mud, bamboo, cane, bricks, stone are the main building materials, which we find in Kutch region of Gujarat (Lathiya, 2016).

*Traditional Architecture of the region*

Three vernacular buildings have been studied which falls in the hot-dry climate of the studied region and has shown characteristics of sustainability and thermal comfort. The identified cases are a (I) Haveli from Rajasthan, (II) Pol house of Ahmedabad and (III) Bhunga house of Kutch. Common characteristics of vernacular architecture have been identified to relate it to the contemporary trend of sustainable architecture. The selected cases were studied on parameters like (1) spatial configuration and building form, (2) materials and construction techniques, (3) passive strategies that are important for

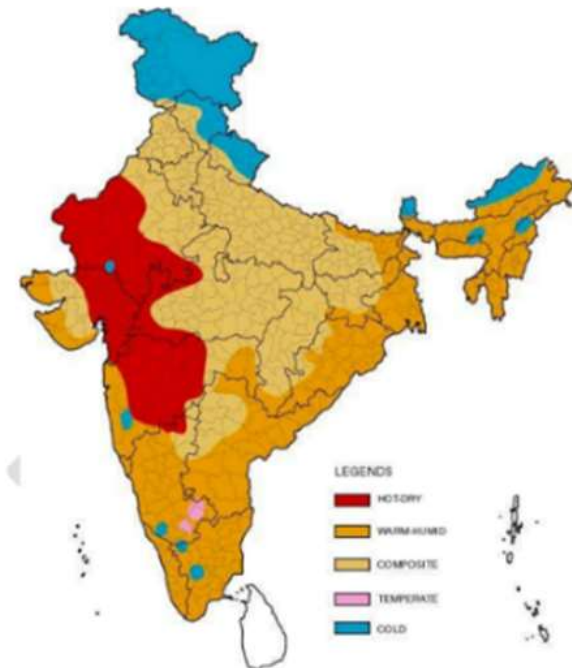

Figure 5. Climate zone map of India

Fig. 1. Climatic map of India (Source: ECBC 2007)

Table 1. Climate data of the study areas

Parameter	Jodhpur, Rajasthan	Ahmedabad, Gujarat	Kutch (Bhuj), Gujarat
Average annual temperature	26 °C (78.8 °F)	27 °C (81 °F)	26.5 °C (79.7 °F)
Average annual rainfall	360 mm (14.2 inches)	800 mm (31.5 inches)	380 mm (15 inches)
Summer temperature range	25 °C to 45 °C (77 °F to 113 °F)	27 °C to 45 °C (81 °F to 113 °F)	28 °C to 44 °C (82 °F to 111 °F)
Winter temperature range	7 °C to 25 °C (45 °F to 77 °F)	12 °C to 25 °C (54 °F to 77 °F)	8 °C to 24 °C (46 °F to 75 °F)
Monsoon season	July to September	June to September	July to September
Summer months	April to June	March to June	March to June
Winter months	November to February	November to February	November to February
Humidity	–	57 %	55 %
Climate type	Arid/Semi-arid	Semi-Arid	Arid

creating good thermal comfort and energy efficiency in buildings.

### **Architecture of a haveli (Palace), Rajasthan** *Spatial configuration and building form*

As it was a male-dominated society with women kept to the home, there was a necessity for spatial segregation, as evidenced by the presence of at least two courtyards. Although, as the interaction between men and women has grown in recent years, the separated zones have become public and private. From the perception of environmental compatibility, courtyards are ideal for the function. During long wedding/festival celebrations, the courtyards become active with a lot of festivities. A back-basement room used for storage and the house is surrounded by the verandah. The plans of the palace are shown in Fig. 2. Due to lack of fenestrations and to break the monotony of flat facades, they were painted to create intriguing facades.

### *Materials and construction techniques*

Stone was readily available in the area. Mud and clay were in little supply and were used sparingly in agriculture. Lime quarries were not close by, but accessing them was easy. Stone was a cost-effective and climatically acceptable material, therefore all of the buildings are made of stone and lime mortar. The roofs are flat, with stone slabs joined with lime mortar and resting on 10×10 cm timber beams separated at roughly 40 cm. Above that, an air layer of inverted earthen pots serves as insulation. On top of it, another layer of lime mortar is applied, this time finished with reflective smooth material such as shattered porcelain pots of white wash to reflect the majority of the sunlight landing on it.

### *Passive strategies*

Sun is controlled by projections and building orientation, buildings receive the least amount of direct sun energy due to shadow patterns. This helps to reduce the peak heat flux into the building during the summer. For ventilation, a combination of the courtyard and internal vertical shafts was used. The courtyard, along with the glass vertical ducts and stair cases, are utilized to deflect wind

down into the dwellings. The outside conditions are attenuated to create comfortable conditions inside the buildings due to the normal thermal lag present, as well as thick construction with good thermal capacity. Natural ventilation inside the building throughout the day is not desired due to hot and dusty breezes and so small apertures are provided. All the openings are shaded with projections which are surrounded by perforated stone screenings known as Jharookhas, which allow the air to cool due to Venturi effect. The staircase mummy was raised, and each chamber was given an opening through which forced ventilation could be conducted. This enables the nighttime convective cooling and daytime induced ventilation; these strategies are presented in Fig. 3.

### **Architecture of Pol houses from Gujarat**

Following the communal riots in 1714, the Ahmedabad's houses were divided into tight neighbourhoods with a single entrance. Residents of each neighbourhood tended to have not only from the same religion, but also from the same caste or occupation group. These areas are known as "pols", which means "gate" or "entrance", and the buildings in these areas are known as *pol houses*.

### *Spatial configuration and building form*

The houses are typically narrow with minimal frontage towards the neighbourhood street, two to four stories high with a small courtyard open to the sky and adjacent buildings (Fig. 4) share walls on either side. The relevance of the house's open spaces grows in the crowded urban fabric. The courtyard, also known as a chowk, is the main feature of the house that connects inside and outside of the house and functions as light well (Fig. 5). Parasol is the veranda space around the courtyard where most of the family life takes place. Otala, which is the front balcony that marks the extent of the house and is used for daily household activities and religious activities. The roofs of the pol houses were sloped to provide shade from the monsoon rains as a space for storage.

### *Materials and construction techniques*

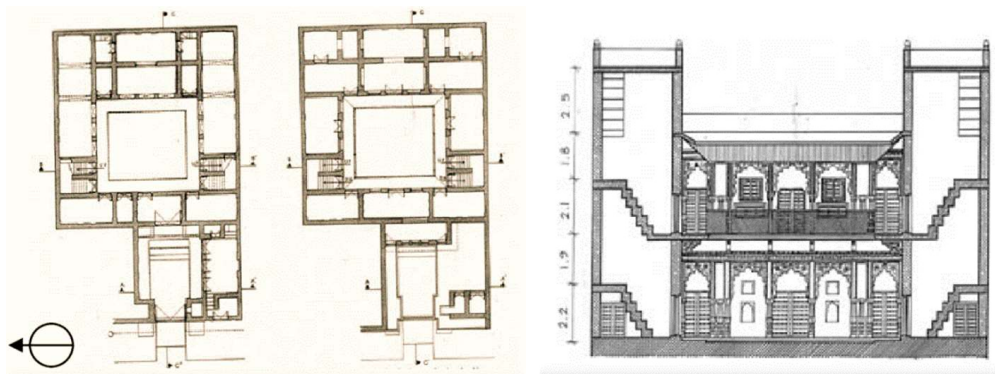

Fig. 2. Typical plans and section of Rajasthan Haveli (Source: Agarwal et. All, 2006)

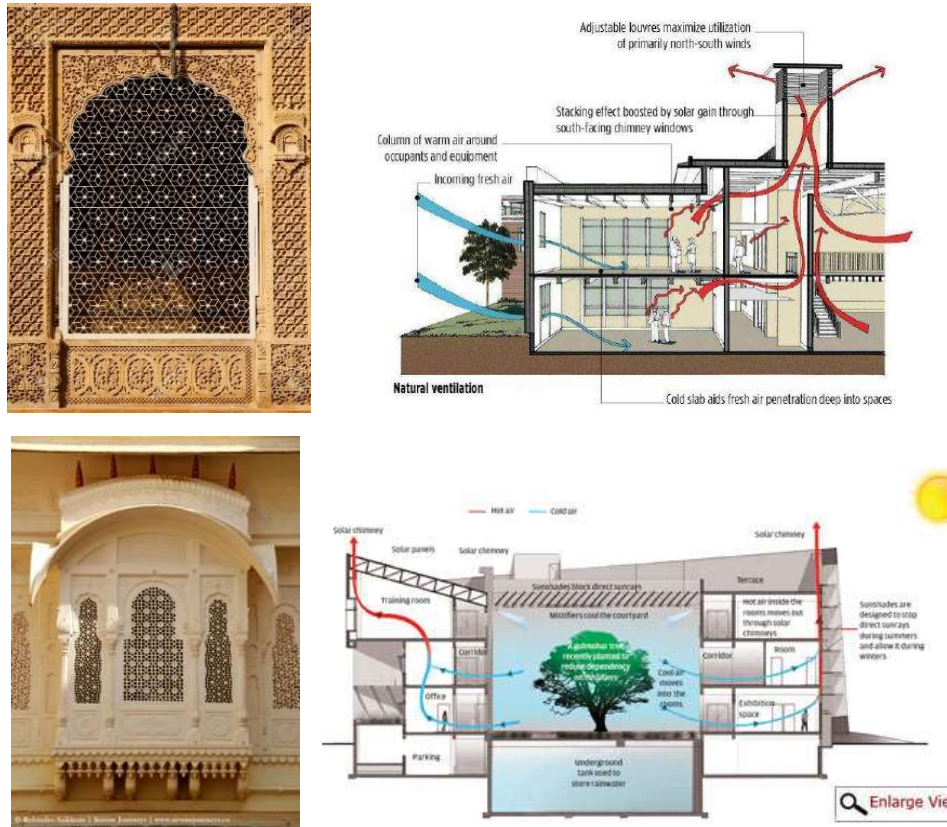

Fig. 3. Jharokha, Staircase mummy working as stack ventilator, Jali & Courtyard in Rajasthani havelis (Source: google image)

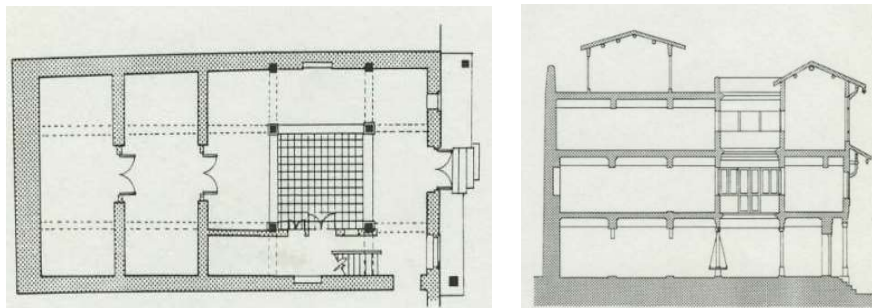

Fig. 4. Plan and section of a Pol house in Ahmedabad (Source: M. Susan Ubbelohde, George Loisos)



Fig. 5. Informal interaction in courtyard (Source: Gangwar and Kaur, 2020)

The construction of Pol houses is typically based on a wooden framework of posts and beams with 16” brick infill walls (Fig. 6). The Foundation was the continuation of the parallel walls which goes up to 2–2.2 m deep while the width is same or twice the parallel wall. The brick walls were plastered on both the sides. The large flat bricks used in these Pol houses help to resist earthquakes because they are stable against overturning. The bonding materials used in brickwork were a mixture of mud and cow dung or lime, which gives sufficient bonding material large sized bricks. This brittle mortar allowed for some movement and plasticity in the wall. The flat slabs were constructed with timber joists and Coba slabs with lime mortar on top. Newly extended slabs

have been made with RCC and sloping roofs are made with wooden beams and GI sheet covering. Structural and ornamental components, like carved columns, brackets, window shutters, and balconies made with wood. There is a provision for chimney over the fireplace (Chula) as an outlet for smoke from the kitchen. Stones are also used as the foundation for columns and doorframes in Pol homes. While the columns are properly pin-connected at the top and bottom, the building can somewhat shake back and forth during earthquakes.

*Passive strategies*

In the summer season the house act like a protective shell which keeps the heat away and creates a microclimatic cooler in the house through the intervention of the Chowk. Thermal capacity of thick walls varying from 12–24” is the key for indoor thermal comfort. Shading is the second most important aspect, due to its tall and narrow structure, the chowk or courtyard lowers solar radiation in summers through reciprocal shadowing. The surrounding walls of the chawl are also shaded with wooden details to shade it from the high-altitude sun (Fig. 7). The rainwater-collecting tank is always beneath the courtyard, and the courtyards specifically constructed floor tiles absorb heat.

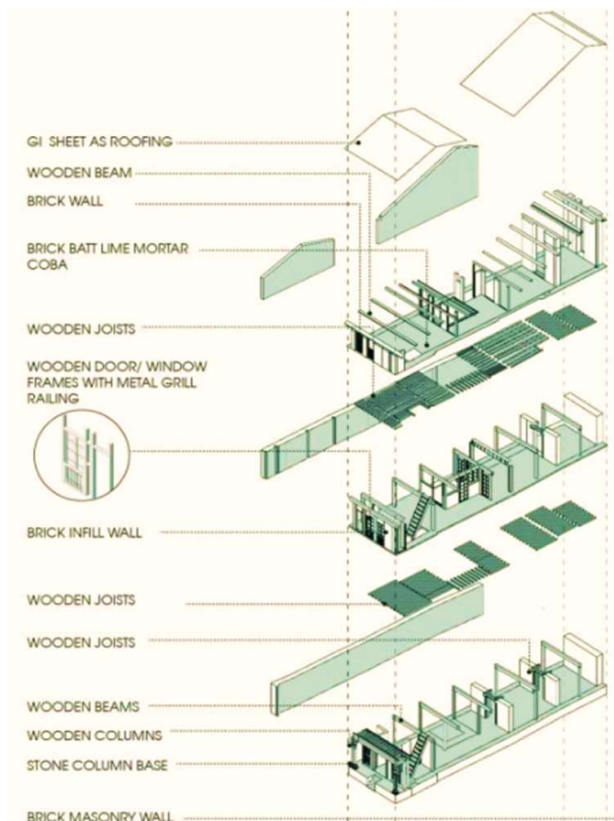

Fig. 6. Exploded axonometric view of construction technique of Pol houses (Source: M. Susan Ubbelohde, George Loisos)

The household activities takes place in the chawl making it a wet place, which eventually allows for evaporative cooling during the summer. Windows are opened at night and are closed by 8 in the morning to allow the night ventilation to cool the house.

**Architecture of Bhunga houses**

Bhunga houses are one of the vernacular dwellings that have developed in response to the prevailing weather conditions by the locales. They are single cylindrical buildings that are stacked close together to form a dwelling for nomadic and seminomadic pastoral communities to live in. Following the earthquake of 1819, building craftsmen in Sindh and Kutch devised the circular house-form design. Even after the earthquake of 2001, it was discovered that the majority of Bhunga houses had survived the disaster, whereas many other structures had collapsed.

*Spatial configuration and building form*

The locals construct circular mud dwellings with thatch roofs, materials that are perfectly adapted to their harsh desert environment. The community of the villages is made up of many vandas. Every varandah is made up of vaases. A vaas is a unified family unit in which everyone stays together and shares one or more shared areas. A single family can start a vaas by building a big plinth on an empty plot, and this plinth usually covers the vaas' future expansion. In most cases, the cooking space is shared by two or more Bhungas. A single plinth connects all of the structures in a vaas (Fig. 8).

The platform of a Bhunga connects the different, separate individual residential units that are not connected to one another. The modulating and flexible surface of the platform naturally maps the



Fig. 7. Façade with wooden carving (Source: Gangwar and Kaur, 2020)



Fig. 8. Development stages of typical Bhunga house (Source: Inside and out, NID, 2019)

growth and multiplicity of individual units. When the family's needs for another unit emerge, an additional Bhunga is built and connected to the house by extending the platform to include the new space within the house's jurisdiction.

As a result, individual privacy is respected and protected. The household may be made up of two or more bhungas, each of them is assigned to one of the same family's married spouses. Bathing and storage are sometimes done in smaller, enclosed chambers that are undefined in shape and lack a roof. The vandh is a polycentric structure in which the middle courtyard spaces are left unoccupied to allow for cross ventilation and daily activities. The courtyard is large enough to accommodate a variety of activities while being small enough to provide shady

areas. Aangan, room, cooking area, otta, veranda, and backyard are typical house layouts (Fig. 9). The aangan, or front yard, is a common meeting place for relatives and visitors. A typical Bhungas have three or four little, low height windows arranged symmetrically around the door.

*Materials and construction techniques*

Bhunga materials are readily available in the Banni region's surroundings (Fig. 10). Chikani Matti (clay) and cow/camel/horse manure are used for the walls and flooring. The roof is made of bamboo from the Babul tree. The term "COB" was commonly used in construction techniques. A big lump is roughly fashioned into the shape of a huge elongated egg, standard size ranges from 12 to 18 inches. These mud cobs are stacked virtually side by side in a row. The sides are smoothed to eliminate the holes and fissures. The wall is constructed of sun dried bricks and compacted stabilised earth blocks.

The beam-adi is hung from the wall horizontally, perpendicular to the door's axis. The ends of the

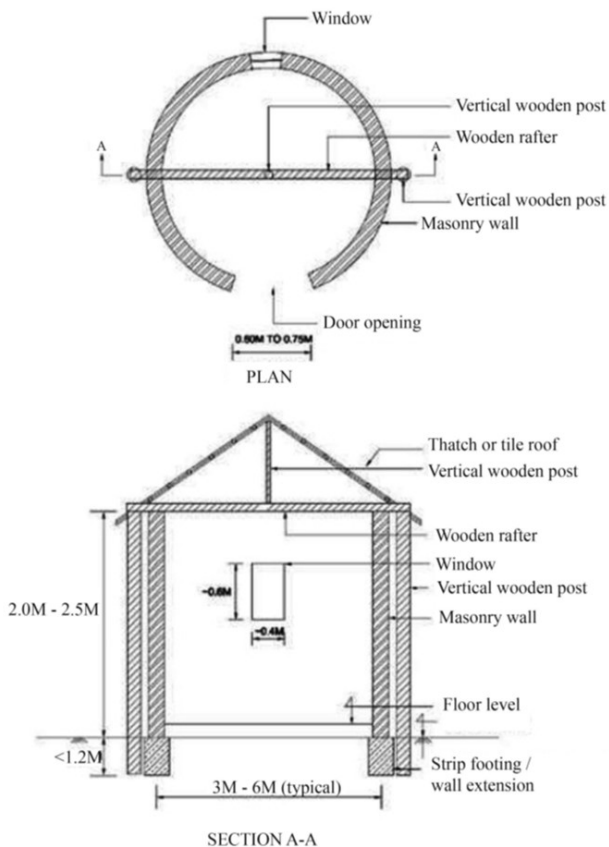

Fig. 9. Plans and sections of Bhunga house (Source: aina.wikidot.com)

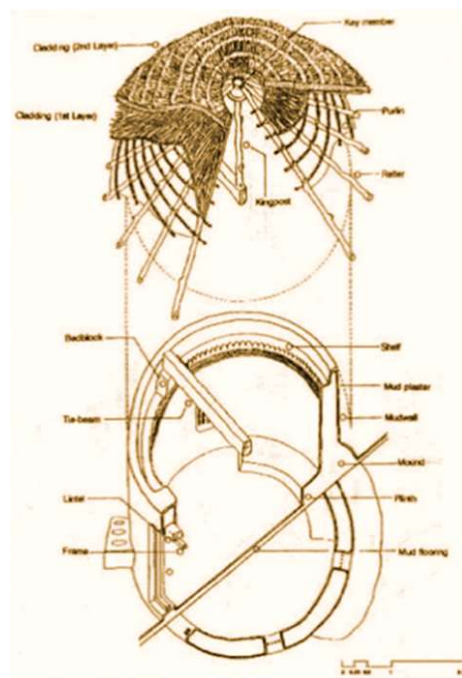

Fig. 10. Exploded view of construction detail (Source: Lathiya, 2016)

beams are attached with pegs to slightly higher parts of the wall. The vertical kingpost's base, patli, rests on the centre of the beam, adi, while the Kingpost stands on the middle of the patli. The kingpost is topped with a cone. Rope is used to secure the joints (vali) at the top of the cone and between them (Kathi). Split bamboo culms (khapatis) occupy the space between the valis and are attached to them. Starting at the bottom, straw bundles (kkeep) are connected to the roof framework. The straw bundles are then held in place by a rope net dropped from the roof's top (Fig. 11).

#### *Passive strategies*

These are compact modules with a low surface to volume ratio to provide the best possible thermal comfort. The thick mud walls and little openings keep inside of the bhungas cool during the day in the summer and somewhat comfortable in the evenings in the winter. This is because the daytime heat is stored in its high-thermal-capacity mud walls. Bhungas have small holes that keep the hot desert breezes at bay. The bhungas' climate-responsiveness is enhanced by thatch, which has high insulating characteristics. A bhunga's roof overhang casts shadows and shields the walls from direct sunlight. Because of its round form, the majority of the surface is shaded and heat is reflected away, making it more convenient for the summer. Thatch is inherently resistant to the elements and does not absorb a lot of water. During the limited rainy season, the bhunga roof's steep slope (minimum 50 degrees) lets rainwater to slip down swiftly. The bhungas' thatched roofs have air spaces that keep them warm in the winter and cool in the summer.

#### *Contemporary architecture with vernacular principles*

Contemporary houses have been identified in the hot-dry climatic zone of India, which were designed according to the vernacular principles and intended to implement those principles with a twist

of modernization. Methodology for selecting the buildings have been described below:

1. As vernacular architecture is very much region specific, case studies have been selected from the hot-dry climatic region of India.

2. Buildings, which have used local material and traditional construction techniques and contemporary technology, have been identified.

These buildings have been studied based on four parameters such as: (1) spatial organisation; (2) built form; (3) material and construction technique; (4) passive strategies adapted for energy efficiency. These studies helped in identification of probable simple and advanced strategies, which can be adapted in contemporary context.

#### *Case study 1: Shunyam residence, Jodhpur, Rajasthan*

Shunyam is a single-family retirement home set on a 2-acre site on the outskirts of the "blue city", Jodhpur in Rajasthan. This building echoing the grandeur of Jodhpur's historic palaces through an explorative merging of the vernacular with the contemporary (Fig. 12). The design's main goal was to create an architectural solution that responded to the local culture, aesthetics, and environment while also meeting modern living needs by incorporating traditional construction processes.

#### *Spatial configuration and building form*

In this single storied house, living areas are free flowing spaces set around two courtyards in a simple geometric pattern. Utilities and service areas are designed along the periphery as an insulating barrier against the weather. Jaalis separate the building masses and open them up to the outside through sandstone arches. First floor houses only meditation room with a pyramidal roof (Fig. 13).

#### *Materials and construction techniques*

The entire edifice was built using traditional stone construction (Fig. 14). In the load bearing RCC foundations (the only use of RCC in the entire

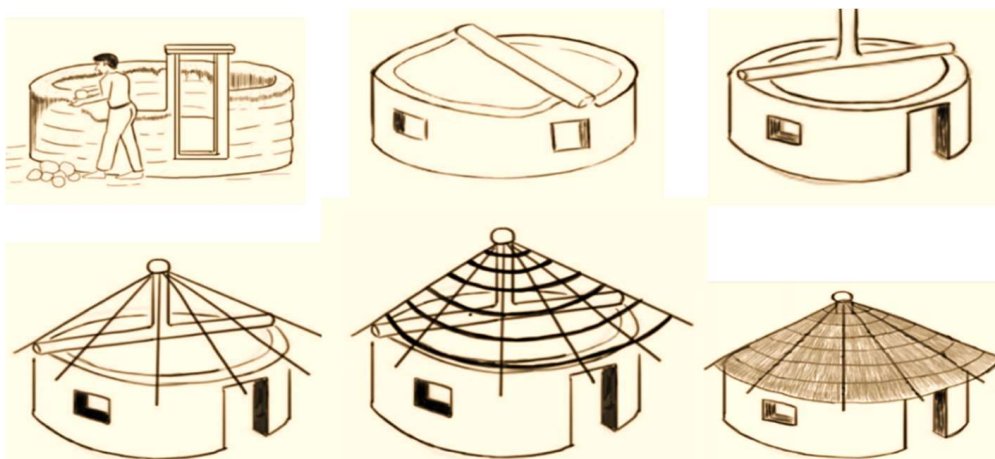

Fig. 11. Stages of construction of Bhunga House (Source: Inside and out, NID, 2019)





Fig. 12. Entrance of Shunyam residence (Source: archiol.com)

project) three layers of 100 mm stone masonry were used. It was constructed with stone on both faces and a middle layer of stone pieces and filled with mortar (Fig. 15). Mild steel (MS) I sections were used as beams and columns. Lime and sand

were used for waterproofing and as mortar for stonework.

Toilet walls are Lime plastered with organic blue colour pigment. For the bedroom flooring, ceiling, doors and for furniture, local Sisam wood was used. Glass was used for door panels, light fittings and crockery cabinets. Printed and woven textiles were used for curtains, furniture, and carpets locally. A roof top was finished with China mosaic. Earthen pots were used as an air barrier over a stone slab on the terrace. Traditional Rajasthani architectural motifs such as jaalis, arches, circular apertures, and jharokhas are carved into Sandstone. Handcrafted wood, glass, and metal doors, furniture, and accessories reinvigorate local crafts while connecting residents to their traditional heritage. The house's materials were all sourced within a 200-kilometer radius of Jodhpur town.

*Passive strategies*

The dual courtyards create positive and negative pressure zones, which aid in the house's passive cross ventilation (Fig. 16). The cooling towers funnel fresh air into the building, chilling it with spray and incorporating it with the cross-ventilation loop to keep the house cosy. Turbo vents just above exhaust spindles extract warm air from living spaces. Earthen pots serve as an insulator on the ceilings, shielding

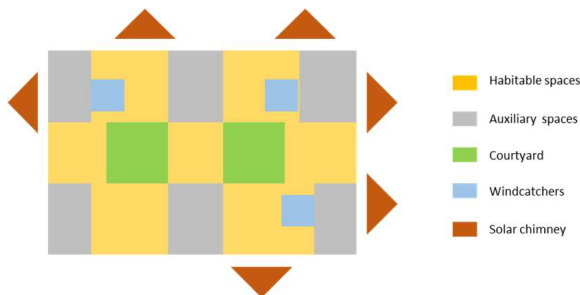

Fig. 13. Spatial zoning & bird's eye view of the house



Fig. 14. Exploded Isometric view & external views of the house (Source: Archiol.com)

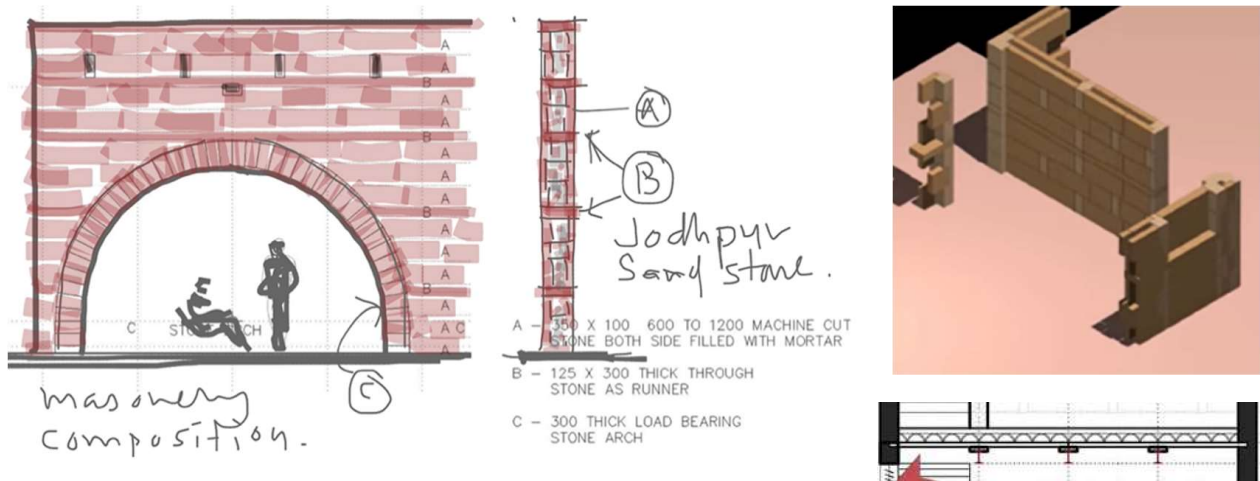

Fig. 15. Load bearing wall with stone and wall & roof details (Source: taoarchitecture.com)

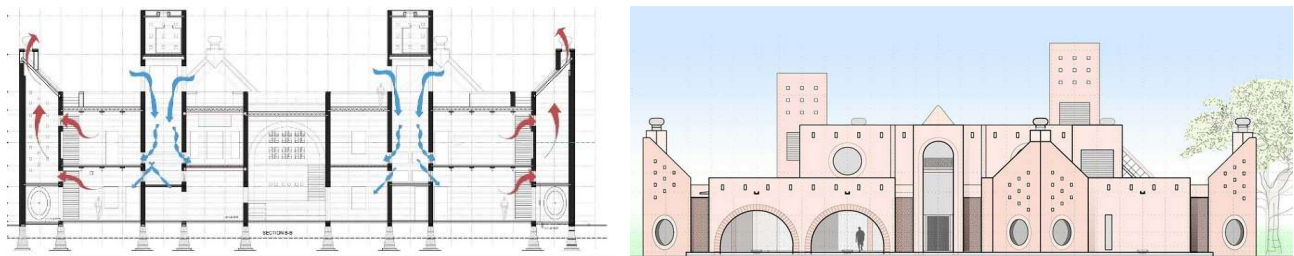

Fig. 16. Natural ventilation through solar chimney and wind catcher & North side elevation (Source: taoarchitecture.com)



Fig. 17. View of stone house

the interior spaces from solar radiation, while China mosaic tiles serve as a roof finish, reflecting sunlight and preventing heat absorption. Gaps in the parapet wall allow air to circulate above the terrace, cooling the surface. All of the confined spaces are on the southern and northern facades, while 90 % of the

semi-covered and open areas are on the east-west axis, allowing for continuous air circulation.

**Case study 2: Stone house, Jaipur, Rajasthan**

The house in Jaipur, Rajasthan with a built up of 8000 sft was designed and constructed using traditional wisdom in architecture. Construction method used in this building has been used in traditional structures in India for ages. Stone was used mostly in the building (Fig. 17). Craft's scope, which had previously been limited to ornamentation, artifice, and an object, was broadened to include architecture. In a space that is both ancient and contemporary, easily consumable symbolism is replaced by the primal and vital deployment of material resources and craft.

*Spatial configuration and building form*

It is three storied building with a semi basement (Figs. 18–19). The house is built around a small courtyard that leads to even smaller openings. Traditional homes' void proportions as a means of mitigating the effects of the scorching summer heat. The ground floor is living areas with bed rooms on the upper two floors. The basement is dedicated to servants' room along with other recreational activities.

*Materials and construction techniques*

The load-bearing building method relies on the thickness of the wall (Fig. 20). This was reengineered

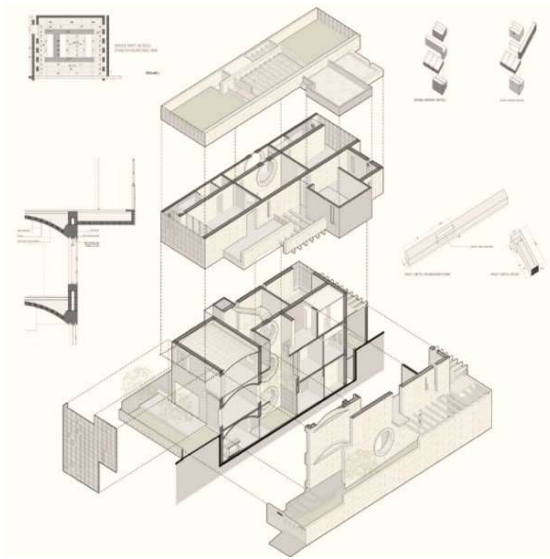

Fig. 18. Exploded Isometric view of the construction technique (Source: archdaily.com)

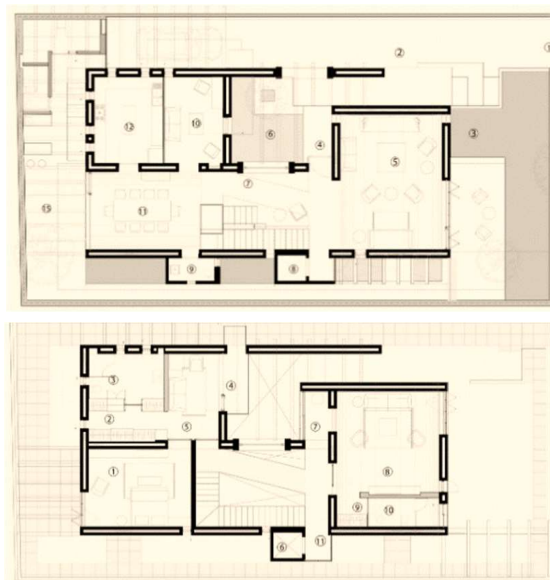

Fig. 19. Floor plans (Source: archdaily.com)

by developing a hollow interlocking structural wall system, which creates an effective thermal break, provides space to integrate services within the wall cavity, and effectively reduces the material

consumption by 30 %. Vaults and massive single-span stone pieces alternate as floor systems. All the elements from the basement raft/retaining walls/lintels/door and window jambs/reveals/stairs/screens etc. have been made from stone blocks, either from the quarry (superstructure elements) or excavated from the site (substructure elements). For a seismic response, a small amount of steel, such as tie-rods and shear pins, were used to support the stone. Only the outside joints are sealed with lime mortar.

*Passive strategies*

The longer surfaces are towards north and south direction. To control light, privacy, and views, large wide overhangs and moveable shade front and back glass, hand-cut stone screens (Fig. 21). Caused by the thermal mass of the material and the "cavity" structure, there is a 5–7 °C difference between the exterior and interior. Finishing of external stone surfaces are kept rough for self-shading as well as for radiative cooling at night due to the increased surface area. A narrow courtyard in the building controls the microclimate as well as cuts off the extra solar radiation. Basement rooms tend to use the cooling from the earth.

**Case study 3: Meethi Mishti Nu Mati Ghar, Ahmedabad, Gujrat**

Meethi-Mishti nu Mati Ghar is a 440 m<sup>2</sup> residence in Ahmedabad designed by Ar. Naman Shah. Meethi (3 years old) and Mishti (3 years old) are the two young patrons of this project. The built-up area of the building is 4 736 sft constructed in a plot of 18 000 sft. Local materials and techniques are used throughout the house, as well as recycling and upcycling, resulting in a low carbon footprint

*Spatial configuration and building form*

The house has two wings of private spaces connected with a double height living space overlooking the veranda (Figs. 22–23). Backside of the house is open to the Sun throughout the day therefore services are placed there. The living room has a sloping glass roof towards the north that caters to the requirement of clients changing the ceiling. Since Ahmedabad gets hot in the summer playground was brought inside the house.

*Materials and construction techniques*

By ramming soil extracted from the site itself into 16" thick structural walls for the house, diverse



Fig 20. Detail of stone used for different types of construction (Source: archdaily.com)

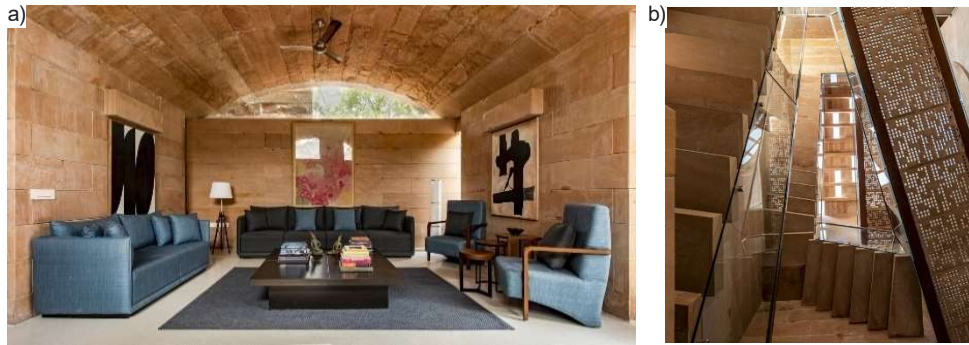

Fig. 21. Vaulted roof with clearstory (a) & Ventilation shaft in hall (b) (Source: archdaily.com)



Fig. 22. Floor Plans (Source: archdaily.com)



Fig. 23. External view of the house (Source: archdaily.com)

natural oxides are used to create layered fluid patterns. It is the largest rammed earth wall built in India. Additionally, few RCC column has been added to the structure. Roofing with RCC slabs supported on the columns and rammed earth walls. Walls other than rammed earth are 9-inch brick with lime plaster. An old building’s wood was repurposed. Wooden pergolas over the veranda are made from packing wood. A glass broken on the site has been used in the terrazzo flooring in the verandah. Toilets are plastered with lime to give a monolithic finish (Fig. 24).

**Passive strategies**

16” thick rammed earth wall on East, West and South side gives thermal insulation from Solar radiation to the habitable spaces due to its high thermal mass capacity. The glass roof over the living room lets in cold north light, which illuminates the house throughout the day and cuts down on electricity use. Blinds have

been provided to close the glass roof if the internal temperature rises beyond certain level. Long overhangs have been provided to shade the glazing surfaces. The roof has been covered with white tile to reflect the maximum amount of solar radiation. Solar panels have been added to offset the required energy demand while shading the roof surface (Fig. 25).

**Inferences from the study**

*Comparison between the traditional and contemporary architecture*

Good Architecture of a building shall be suitable for its environmental context, and should adequately protect the inhabitants from the climate. Further, it should safe guard the environment from potential pollution and degradation caused by human habitation (Bennetts et al, 2004). The architecture of today is radically different from the images of the vernacular associated with space. The change in the economy and globalization has paved way for



Fig. 24. Flooring in lobby (a) & Wash room with lime plaster (b) (Source: archdaily.com)



Fig. 25. Roof top solar panels (a), Large overhangs (b) and Rammed earth wall (c)

manufactured materials and has caused a profound change in the vernacular architecture.

**I. Orientation.** Contemporary and traditional houses of the region have followed the same concept of East-west as longer axis.

**II. Building form.** Rajasthan havelis used the concept of twin courtyards and the architect for designing Shunyam residence adapted the same system. The stone house located in Jaipur; Rajasthan also followed the concept of a narrow courtyard just like the Pol houses of Ahmedabad.

**III. Roof system.** All the traditional houses selected were constructed with either a flat roof or sloped roof, whereas all the selected modern houses were constructed either with flat roof or with combination of flat roof and sloped roof.

**IV. Spatial configuration.** All the traditional houses were designed with activities around the courtyard with public activities either in the verandah or in courtyard. Whereas the contemporary houses followed the similar concept by designing all the public activities around the courtyard with private spaces separated for privacy. It is mainly due to the change in life style over the period as human beings are giving emphasis on private spaces for individuals over and above the family spaces.

**V. Walls.** Traditional houses had used the wall assemblies like stone, Adobe, COB and burnt clay brick. In the similar lines, architects of the

contemporary buildings also used materials like dressed sandstone, rammed earth and burnt clay brick and used glass. The difference may be the clay brick that is now manufactured with using straw along with mud and use of glass.

**VI. Roofs.** Stone slabs, flat slabs with timber joists/ steel "I" sections and Coba slabs with lime mortar, split bamboo with wooden beams were used in traditional buildings whereas in contemporary structures, RCC roofs, vaulted roof and an earthen pot are used.

**VII. Passive strategies.** High thermal mass walls, courtyards for evaporative cooling, Mumty walls as wind catcher, shading through Jalis and projections, and balconies were used predominantly in traditional buildings. In contemporary houses, latest technologies like reflective tiles for roofs, sloped glass roofs, movable blinds along with vernacular elements like Jalis in modern designs, modernized Jharokhas were.

The comparisons between the studied buildings of vernacular architecture and modern architecture is presented in table 2.

#### Discussion

The use of red sandstone and elaborate carvings define Jodhpur's traditional architecture. Along with materials like stone, brick and lime plaster. Traditional buildings were designed with courtyards, thick walls, Jharokhas and flat roofs. The indoor temperatures were kept low even during the

**Table 2. Comparison of traditional and contemporary dwelling studies in this research**

Si. No.	Strategies	Rajsthani Haveli	Pol Houses	Bhunga Houses	Shunyam Residence	Stone House	Meethi Mishthi Nu Residence
I	Orientation	E-W longer axis	E-W longer axis	No particular orientation	E-W longer axis	E-W longer axis	E-W longer axis
II	Building Form	Compact with twin Courtyard	Linear with narrow central Courtyard	Individual circular units	Compact with twin Courtyard	Compact with narrow central Courtyard	Compact without Courtyard
III	Roof form	Flat roof	Flat & sloped roof	sloped roof	Flat roof	Flat & Vault roof	Flat & sloped roof
IV	Spatial configuration	Spaces around courtyard with Verandah	Linear spatial planning, public spaces around courtyard	Separate circular rooms connected with a common plinth	Habitable Spaces around courtyard, buffer spaces in the periphery	Public & living Spaces around courtyard, private spaces separated	Two wings of private spaces connected with living space
V	Wall Materials	Sandstone, RR masonry	Wooden frame, brick infill	COB/Adobe/ burnt Brick	Dressed Sandstone masonry	Cavity wall with Sandstone	Rammed earth and burnt Brick
VI	Roof Materials	Stone slab Earthen pot + + Lime mortar & Porcelain finish	Wooden beam + COB + + Lime mortar/ GI roof/RCC	Wooden beam + + split bamboo + + straw	Stone slab Earthen pot + + Lime mortar & China mosaic	Stone vault + light weight filling + + PCC/stone slabs + PCC	Exposed RCC frame structure
VII	Passive Strategies	Shading through Jali/ Jharokha/ wooden lovers/ vegetation/Sun shades	Shading through wooden details, projected balconies	Low surface to volume ratio	Reflective tiles as roof covering & Jalis for shading	Extensive use of hand cut stone jalis & modern Jharokhas	Reflective tiles as roof covering & sloped glass roof
		Mumty and tall shafts as wind catcher	Courtyard as a ventilating and lighting shaft	Long roof overhang for shading	Three wind towers over habitable spaces	Stair case space for stack ventilation	Large overhangs and movable blinds
		Evaporative cooling through courtyard	Evaporative cooling through courtyard	Thermal mass of the walls and insulation for the roof	Six solar chimneys	Shading with Jali/ self-shading	Vegetation for shading

most intense heat seasons by using architectural features like high ceilings, courtyards, Jharokhas and Jaalis. In the contemporary residential building, blends both modern and traditional elements were observed. Vernacular features like courtyard and Jalis and materials such as stone and brick were used in modern buildings mimicking the traditional architecture of the place. They have also used modern materials like concrete, glass and steel along sandstone to offers utility as per modern life style yet with traditional looks. Ahmedabad is known for its traditional Pol houses, which have compact and inward-facing dwellings with internal courtyard. These provide natural ventilation and cooling in the hot and dry climate of Gujarat. They used locally available materials like mud, brick, and clay and intricate wooden carvings can be seen, these features promote cooling and airflow. The studied buildings from Ahmedabad were designed with internal courtyards, thick walls for better cooling and thermal comfort inside the residence. They are aesthetically contemporary with minimalist, functional, and sleek designs. The use of mud, clay, cow dung and straw characterise the traditional residential architecture of Kutch. Bhungas that had thick mud walls and thatched or tiled roofs could be seen all around. These were well insulated to withstand heat and earthquake.

It used to be decorated with local art making it simple yet functional. These were sustainable and were clustered in villages reflecting a strong sense of community and mutual support. The contemporary buildings in the present study have used modern construction strategies to improve sustainability, ventilation and cooling techniques with large windows with sunshades. But with the use of intricate woodwork and colourful facades, they portray the aesthetics of the traditional architecture of the place. They were designed with modern designs fused with traditional materials to create unique living spaces that cater to modern lifestyles. The use of wood in interiors with modern elements gives the look of traditional buildings. These modern buildings utilises concrete and steel as the main materials in addition to bamboo, COB etc. Hybrid designs incorporating traditional styles is used to maintain a comfortable indoor temperature apart from the ACs and enhance earthquake resistance while retaining traditional aesthetic elements. Minimalistic approach can be seen in contemporary architecture. In Kutch, reconstruction efforts post-natural disasters have integrated modern, resilient building techniques. This architectural evolution not only enriches the cultural and visual landscape of these regions but also ensures their adaptability and growth in a rapidly changing world.

## Conclusions

Jodhpur, Ahmedabad, and Kutch's residential architecture is a testament to the artistic prowess, innovative architectural techniques, and a rich cultural legacy of the respective regions belonging to the same climate. It reflects the historical practices and adapts to local climatic conditions. While contemporary architecture demonstrated how architects used these classic aspects in the current designs, traditional architecture displays historical workmanship and environmentally friendly building techniques. The blend of traditional and contemporary elements in residential architecture results in aesthetically pleasing and functionally efficient homes. This fusion caters to modern lifestyles while respecting historical and cultural contexts. The study tried to focus on the integration of some of the aspects of vernacular architecture into contemporary architecture. The effects of globalization and westernization influences the architectural practices leading to the loss of the unique characteristics of vernacular architecture. Aesthetics of contemporary architecture does not have continuity with its surroundings because it suffers from diverse and foreign elements and materials. In modern construction industry as the use of rigid modular

elements increases, we should also recall that entropy works fastest on the most unnatural shapes. Till now the architectural vocabulary in India is greatly influenced by the West which does not necessarily respond to the dictates of the context in terms of climate, related lifestyle responses, technological appropriateness and aesthetic relevance. In order to re-orient architectural responses for the local, architects are looking at the sources of inspiration from the traditional buildings from the past to make the buildings more meaningful. The works of many contemporary architects have shown innovation in technology in combination with sustainable materials to create new vernacular architecture. The nature of sustainability and that of vernacular architecture in the modern form are discussed with the help of identified case studies. The study analysed the vernacular and contemporary architecture in three different regions under the same climatic context in India. This study highlighted the importance of adopting vernacular architecture in contemporary needs while maintaining cultural identity, sustainability and response to climate. It demonstrated how traditional construction techniques can be integrated with modern design to create functional and aesthetically pleasing spaces.

## References

- Agrawal, A., Jain, R. K., and Ahuja, R. (2006). Shekhawati: urbanism in the semi-desert of India: A climatic study. *PLEA 2006-23rd conference on passive and low Energy Architecture*, Geneva, 6-8 September 2006, pp. 1–7.
- archiol.com (2024). Architecture Online [online] Available at: [www.archiol.com](http://www.archiol.com) [Date accessed April 25, 2024].
- archdaily.com (2024). Broadcasting Architecture Worldwide [online] Available at: <https://www.archdaily.com> [Date accessed April 25, 2024].
- Bennetts, H., Radford, A., and Williamson, T. (2002). *Understanding Sustainable Architecture* (1<sup>st</sup> ed.). London: Taylor & Francis. DOI: 10.4324/9780203217290.
- Biswas, B. (2009). Rajasthan's Sustainable Development at Crossroads. *Social Change*, Volume 39, Issue 1, pp. 160–169. DOI: 10.1177/004908570903900113.
- Gangwar, G. and Kaur, P. (2020). Traditional pol houses of Ahmedabad: An overview. *Civil Engineering and Architecture*, Vol. 8, Issue 4, pp. 433–433. DOI: 10.13189/cea.2020.080405.
- Inside and out, NID (2019). *A document by Shreya Patil* (TGD- 2017), NID, Ahmedabad. [online] Available at: [https://nid.edu/download/AnnualReport/NIDAnnualReport\\_201920\\_En.pdf](https://nid.edu/download/AnnualReport/NIDAnnualReport_201920_En.pdf) [Date accessed April 25, 2024].
- Jagatramka, R., Kumar, A., and Pipralia S. (2020). Sustainability Indicators for Vernacular Architecture in India. *ISVS e-journal*, Vol. 7, Issue 4, pp. 53–63.
- Krishan, A. (1996). The habitat of two deserts in India: hot-dry desert of Jaisalmer (Rajasthan) and the cold-dry high-altitude mountainous desert of Leh (Ladakh). *Energy and Buildings*, Volume 23, Issue 3, pp. 217–229. DOI: 10.1016/0378-7788(95)00947-7.
- Lall, A. (2010). Evolving Traditional Practices for Sustainable Construction in the Present. In: Pracsad D. (ed.) *New Architecture and Urbanism: Development of Indian Traditions 2020*. Newcastle upon Tyne: Cambridge Scholars Publishing, pp. 179–183.
- Lathiya, N. B. (2016). Traditional Architecture of Kutch Region of Gujarat. *International Journal of Engineering Development and Research*, Vol. 4, Issue 1, pp. 593–597.
- Martinovic, S., Zecevic N., and Salihbegović, A. (2023). Vernacular Residential Architecture in the Context of Sustainability – Case Study of Svrzo's House Complex. *Journal of Sustainable Architecture and Civil Engineering*, Vol. 32, Issue 1, pp. 19–40.
- Moor, T. (2017). *Reinventing an Urban Vernacular: Developing Sustainable Housing Prototypes for Cities Based on Traditional Strategies* (1<sup>st</sup> ed.). Routledge. DOI: 10.4324/9781315545097.

- Nagaraju, K. (2017). A Review of Energy Efficient Techniques in Vernacular Architecture of North Indian Plain. *International Journal of Engineering and Advanced Technology*, Volume 6, Issue 5, pp. 177–182.
- Olukoya, O. A. P. and Atanda, J. O. (2020). Assessing the Social Sustainability Indicators in Vernacular Architecture — Application of a Green Building Assessment Approach. *Environments*, No 7, 67. DOI: 10.3390/environments7090067.
- Ubbelohde, S. and Loisos, G. (1990). The Ahmedabad pol house: Courtyard strategies in a hot-dry /hot-humid climate. [online] Available at: [https://coolshadow.com/wp-content/uploads/2023/03/LU\\_The-Ahmedabadi-Pol-House.pdf](https://coolshadow.com/wp-content/uploads/2023/03/LU_The-Ahmedabadi-Pol-House.pdf) [Date accessed April 27, 2024].
- Rajpu, Y. and Tiwari, S. (2020). Neo-Vernacular Architecture: A Paradigm shift. *Palarch's Journal of Archaeology of Egypt/ Egyptology*, Vol. 17, Issue 9, pp. 7356–7380.
- Rathore, M., Sharma, S. K., and Preet, V. (2018). Analysis of Traditional and Existing Construction Practices for Sustainable Rural Houses in the Southern Western Part of Rajasthan. *International Journal of Engineering Research & Technology*, Vol. 6 Issue 11, pp. 1–7.
- Rudofsky, B. (1987). Architecture without architects: a short introduction to non-pedigreed architecture. *University of New Mexico Press*, Albuquerque.
- Salman, M. (2018). Sustainability and Vernacular Architecture: Rethinking What Identity Is. In: Hmood K. (ed.) *Urban and Architectural Heritage Conservation within Sustainability*, Intech open. DOI: 10.5772/intechopen.82025.
- Thakkar, J. and Routh, R. (2019). Re-engaging Vernacular Building Practices Facilitating the Revitalization through a Systematic Approach. In: *South asian vernacular architecture - Challenges to its Continuity and Strategies for its Future*. Bhopal: SPA Press, School of Planning and Architecture.
- Tipnis, A. (2012). Vernacular traditions: Contemporary architecture. *The Energy and Resources Institute (TERI)*.
- Vedamuthu, R., Dhakshinamoorthi, J., and Sasidhar K. (2014). Adaptive reuse and restoration of a chettinadu mansion, Pudukkottai, Tamilnadu, India. [online] Available at: <https://pdfcoffee.com/adaptive-reuse-and-restoration-of-a-chettinadu-mansion-pdf-free.html> [Date accessed April 27, 2024].

## АДАПТАЦИЯ МЕСТНЫХ АРХИТЕКТУРНЫХ ОСОБЕННОСТЕЙ В СОВРЕМЕННОЙ АРХИТЕКТУРЕ В УСЛОВИЯХ ЖАРКОГО И СУХОГО КЛИМАТА В КОНТЕКСТЕ ИНДИЙСКОГО СУБКОНТИНЕНТА

Кайя Нагарайю\*, Бенарджи Саяк

Школа планирования и архитектуры, г. Виджаявада, Индия

\*E-mail: [nagaraju.kaja@spav.ac.in](mailto:nagaraju.kaja@spav.ac.in)

### Аннотация

**Введение.** В связи с урбанизацией во всем мире происходит смена парадигмы строительной практики в сторону энергоемких строительных материалов и методов проектирования. Здания, построенные с учетом местных архитектурных особенностей, и традиционные знания исчезают, хотя у них есть потенциал для адаптации к изменениям и трансформации в соответствии с меняющимися потребностями городского образа жизни. Некоторые архитекторы пытаются уловить принципы местных архитектурных особенностей и применить свое собственное понимание в современных проектах с контекстуальным проявлением традиционных принципов в условиях изменяющегося времени. Этот тип архитектуры известен как новая национальная архитектура. **Цель исследования:** выяснить, оказывает ли местная национальная архитектура влияние на современных архитекторов при проектировании устойчивых зданий? Как эта традиционная мудрость трансформируется в новое измерение, чтобы удовлетворить требования и изменения в стиле жизни в наши дни. Кроме этого, чтобы узнать, насколько эти традиционные знания успешны в удовлетворении потребностей людей 21-го века. **Методы.** Традиционная архитектура выбранных зданий в жарком и сухом климатическом регионе Индии была изучена и сравнена с современными зданиями, спроектированными с использованием принципов народной архитектуры в отношении пространственной конфигурации, формы, строительных материалов, пассивных солнечных стратегий и т. д. **Результаты.** Исследование показало, что архитекторы современной эпохи изменили принципы местной архитектуры, чтобы использовать ее в современном контексте для большего комфорта и соответствия современному стилю жизни людей, придав новое измерение народной архитектуре.

**Ключевые слова:** адаптация; жаркий и сухой климат; новая национальная архитектура; строительная среда.



# Building operation of buildings and constructions

DOI: 10.23968/2500-0055-2024-9-4-49-64

## AN IOT-BASED EARTHQUAKE EARLY WARNING SYSTEM WITH FUZZY LOGIC FOR UTILITY CONTROL IN TEHRAN

Mahdi Akhavan\*, Pooria Rashvand, Mehran Seyed Razzaghi

Qazvin Branch, Islamic Azad University, Qazvin, Iran

\*Corresponding author's email: info@mahdiakhavan.com

### Abstract

**Introduction:** In disaster scenarios, while predicting disasters is challenging, preparation is essential. Internet of Things (IoT) technology, which is well-established, can play a significant role in disaster management. For countries, especially those prone to seismic activity, implementing early warning systems is critical to saving lives and minimizing damage. These systems alert individuals and authorities when disasters strike. However, limited attention has been given to post-disaster decision-making for monitoring essential utilities, such as gas and electricity, during critical times. **Methods:** Integrating IoT with a Fuzzy system can improve decision-making after disasters, reducing costs and destruction in urban areas. Tehran, a city with high seismic risk and an extensive gas network, faces significant dangers from damage to gas and electricity systems in the event of a major earthquake. **Results:** The research highlights that the proposed IoT-Fuzzy system performs effectively when compared to the JICA Seismic Hazard Assessment of Tehran. It issues disconnection commands for critical utilities within 10 seconds based on predicted damage levels, helping to reduce secondary damage after an earthquake. This system shows promise in improving post-disaster response and safeguarding urban infrastructure.

**Keywords:** crisis management; internet of things; fuzzy system; early warning system; smart city; city management.

### Introduction

Earthquake often takes place in particular regions across the world. On a worldwide scale, this disaster causes 2.5 million deaths and destroyed many buildings and infrastructure between 1900 to 2018 (Database, 2019). Therefore, it is important to apply novel technologies as an early warning system to reduce injuries and destruction (Mali and Kumbhar, 2016). Traditional earthquake warning systems, such as seismic networks and ground motion sensors, have demonstrated their importance, but they often face challenges such as delayed response times and limited geographic coverage, particularly in densely populated urban areas. These limitations highlight the need for more efficient and responsive systems that can collect real-time data and trigger rapid decisions.

The recent mega earthquakes damaged to the gas pipeline and infra-structures of the urban area. During the Kobe earthquake the shutdown of the related valves to isolate these blocks began six hours after the earthquake and the last block was isolated 15 hours after the earthquake (Katayama, 2004). Such long delays underscore the inadequacy of traditional, manual-response systems, which are not fast enough to prevent extensive damage and loss of life. Other destructive earthquakes such as San Fernando earthquake in 1971, the Loma Prieta seismic event of 1989, Izmit earthquake in 1999

and San Salvador seismic event in 2001, resulted in damaging the pipelines and infra-structures and left sever injuries (Manshoori, 2011).

The risk of a catastrophic earthquake threatens Iran every year (Database, 2019). Tehran, the capital of Iran, is one of the most populated cities in the world. The city is surrounded by several active faults and thus is at a high risk of a sudden destructive earthquake. The gas transmitting network on the other hand, spreads throughout the city. Thus, occurring catastrophic disasters same to Kobe and Izmit events is probable in Tehran.

Many of natural disasters are unpredictable. Therefore, it is necessary to develop a technology to collect appropriate indicators as fast as possible. However, current systems for earthquake monitoring and response often lack the capability to deliver data at the necessary speed, and their reliance on human intervention can result in delays. IoT is known as one of the pioneering technologies, which is susceptible to data changes and can send the sensed critical data in real-time to the cloud server. Nowadays, IoT plays a dynamic role in diverse areas such as national defense, smart grid, intelligent transportation, smart home, and healthcare (Maglogiannis, 2012; Zhou, 2012). However, while IoT is excellent for real-time data collection, it requires robust decision-making systems to interpret and act on that data efficiently in the case of emergencies.

Lack of real-time precise information about the response of structures and infrastructures leads to the amplification of disasters. The traditional threshold-based warning systems fail to handle the complex and often ambiguous data produced during earthquakes. The IoT technology seems to be an appropriate tool to monitor and manage such issues at the early moments of a post-event, which consequently leads to reduced fatalities and indirect impacts. However, IoT alone may not suffice when rapid and complex decision-making is required. This is where fuzzy logic comes into play. By integrating IoT with fuzzy logic, we propose a more intelligent and adaptive system that can interpret various sensor inputs under uncertain conditions, providing more accurate and faster decisions. Pairing IoT with a fuzzy system can help a crisis manager create a more proactive and efficient network capable of forecasting and managing earthquakes. Such a network may associate with tens of sensing nodes to measure accelerometer data and dispatch them to the cloud server. The measured data is compared to the pre-defined values in the fuzzy system to check if significant changes have occurred.

The proposed system addresses key limitations of current approaches by integrating IoT with fuzzy logic to create an intelligent early warning system that can analyze data more dynamically and respond faster. This paper aims to define the sensor network design for an earthquake early warning system developed based on IoT architecture, incorporating practical experiences and theoretical knowledge. The system is proposed for the possible safe shutdown of gas and electric transmission networks.

This model considers an additional element that may attach to the operational sensors and can process the data using decision-making criteria (DMC). The DMC is defined in the cloud layer and can execute the relevant scenario to reduce indirect loss. By leveraging the fuzzy system's ability to handle ambiguity, the proposed system can enhance decision-making under uncertain conditions, providing quicker and more accurate responses than traditional methods.

#### *Literature review*

Since Kevin Ashton introduced the Internet of Things (IoT) in 1999, there has been a significant surge in the number of devices connected to the internet. Currently, these devices are utilized across various application domains (Atzori et al., 2010). Since the introduction of the Internet of Things (IoT) by Kevin Ashton in 1999, there has been a notable increase in the quantity of devices connected to the internet. At present, these devices are employed across a diverse range of application domains.

The IoT system typically consists of sensors or devices that communicate with the cloud via some form of connectivity. Once the data reaches the cloud,

software processes it and might trigger an action, such as sending alerts or automatically adjusting the sensors or devices — thus enabling IoT to operate autonomously without user intervention. This capacity for real-time, automated responses makes IoT particularly suitable for disaster management, where timely action is critical.

Today, a broad spectrum of industries, from transportation and logistics to healthcare, smart environments, and knowledge management, can benefit from IoT technologies. The continued development of new smart devices and internet-connected products suggests that futuristic applications such as robot taxis, city information models, and enhanced game rooms will soon become mainstream (Nord et al., 2019; Jahanbakhshian et al., 2020; Thoma et al., 2012). Moreover, IoT technologies play a critical role in disaster relief operations, aiding in the planning, management, and analysis of both immediate and long-term impacts (Azizzadeh, 2022; Jianshe et al., 1994).

In the context of earthquake disaster mitigation, recent studies have demonstrated the effectiveness of IoT. For instance, a pilot study validated the integration of IoT technology with ShakeMap data for earthquake early warning systems. The platform was shown to optimize emergency responses by categorizing actions into automatic responses, guidance, and system automation. This demonstrates IoT's potential to enhance public safety during seismic events, making real-time data processing and rapid decision-making possible (Ahn et al., 2024).

One of the primary activities enabled by such technologies is the timely delivery of relief supplies from distribution centers to hospitals in coordination with the schedules of medical teams (Lee et al., 2006). However, effective crisis management planning also depends on several other factors, including climatic conditions, topology, habitat, and the availability of resources (Duhamel et al., 2016). The ability of IoT to provide real-time data on these variables can significantly improve the precision and effectiveness of disaster response.

Recent advancements have led to the development of IoT-based earthquake early warning systems. For example, one system, which utilizes smartphone sensors, Sensor Web Enablement (SWE), and MQTT, was designed for Ecuador's seismic activity and offers up to 12 seconds of warning before the peak seismic impact. This system emphasizes real-time monitoring, customization, and addresses concerns related to energy consumption and user safety (Zambrano et al., 2017). Such systems highlight the practical benefits of IoT in early disaster warning and management, providing communities with crucial seconds to mitigate potential damage.

The term fuzzy logic, introduced by Zadeh in 1965, refers to a form of multivalued logic in which truth values can range between 0 and 1 (Zadeh, 1965). It is used to handle the concept of partial truth, where values can extend between completely true and completely false. Fuzzy logic is particularly valuable in situations where data is uncertain or imprecise, which is often the case during natural disasters like earthquakes. When paired with IoT, fuzzy logic can enhance decision-making by processing complex data and providing a more nuanced understanding of risk.

Fuzzy logic has been widely adopted in civil engineering, especially in earthquake engineering for tasks such as crisis management (Nokhbatolfighahaayee et al., 2010), crisis management in gas transmission networks (Foghahaayeea et al., 2014), hazard evaluation (Şen, 2011), motion earthquake records (Ahumada, 2015) and Earthquake Prediction (Valizadeh et al., 2024). However, a significant research gap exists regarding the integration of IoT and fuzzy logic for earthquake mitigation. While IoT provides a real-time data stream, fuzzy logic can analyze this uncertain and imprecise data, enabling more effective disaster response systems.

Moreover, the role of IoT in disaster management extends beyond earthquakes, with various solutions being developed to address disasters like fires and earthquakes. IoT architecture and its implementations, such as early-warning systems, offer valuable insights for stakeholders in securing smart city infrastructure and effectively managing disaster risks (Abdalzaher, 2023; Sharma et al., 2021; Pierleoni, 2023). This study aims to address this gap by proposing an IoT-based earthquake early warning system that integrates fuzzy logic to improve crisis management and the operational reliability of critical infrastructures such as gas and electricity networks.

## Methods

### *Theoretical Background*

An image of the current literature associated with the studied topic is presented herein. The key role of technology in disaster management is helping to relief forces to More purposeful helping to injury. There is no doubt that efficient emergency response management following an earthquake is a critical element in reducing seismic risk. Research has shown that inadequate emergency responses or secondary disasters can increase the death toll from an earthquake by up to tenfold.

Japan, holding a leading position internationally, places great importance on observational experiments both indoors and outdoors, landslide debris flow studies, research on forecast models, early warning system research, and the advancement of monitoring systems for landslides

and debris flow (Takaoka, 2006). Individuals will have between a few seconds to several dozen seconds to respond, depending on their location. According to the performance report by the Japan Meteorological Agency (JMA) on the earthquake early warning (EEW) system for the Mw 9.0 Tohoku earthquake in 2011 (Hoshiba et al., 2011; Hoshiba and Ozaki, 2014). An earthquake early warning (EEW) was issued more than 15 seconds before the onset of intense ground motion in Tohoku, which was relatively close to the epicenter. This is an excellent example of the effectiveness of an EEW system. The Istanbul Earthquake Rapid Response and Early Warning System (IERREWS) is identified as an EWS solution for earthquake threats. The system collects seismological data through 100 robust motion accelerometers, enabling a better understanding of seismic wave propagation (Erdik et al., 2003).

The fast loss estimate systems is applied in Japan and Taiwan at present defined respectively (Fumio, 2001; Yeh et al., 2006).

A fast loss estimate instrument known as Earthquake Loss Estimation Routine (Bogazici University) was made by the European Commission (EC) funded Network of Research Infrastructures for European Seismology (NERIES) (Özbey et al., 2004) to be applied by European agencies, among them the European Mediterranean Seismological Center (EMSC) to compute and broadcast earthquake loss estimations of near-real-time to the related emergency reaction organizations (Strasser, 2008).

The effectiveness of earthquake early warning (EEW) systems in mitigating earthquake hazards and reducing casualties, particularly in major earthquakes, has been thoroughly demonstrated in both Japan and Mexico (Doi, 2011). In Mexico, earthquake alerts from the seismic warning system were transmitted to Mexico City more than 60 seconds before the destructive waves arrived, facilitated by 12 digitally strong motion field stations along the Coast of Guerrero. In Japan, the earthquake early warning (EEW) system is supported by over 1,000 uniformly distributed stations across the country, providing real-time monitoring data. Both inland and offshore earthquakes are detected, and warnings are issued when the maximum seismic intensity on land exceeds five lower (approximately VII on the Modified Mercalli Intensity scale). The proposed on-site earthquake early warning system (EEWS) has demonstrated an 80 % success rate in accurately predicting earthquake intensity levels and can automatically send an alarm message at least eight seconds before the peak S-wave trains reach the earthquake epicenter (Seng).

The United States Geological Survey (USGS) has been working on a method to detect earthquakes shortly after they begin. This method involves first calculating the energy of the P-wave, which

subsequently provides data on the earthquake's location and intensity.

According to Buzduga et al. (2015), in the event of a survivor in a collapsed building, the electrostatic sensor transmits information via a radio transmitter, which is received by a radio receiver. The survivor's exact location is then identified by the connected microcontroller. Dan Wang et al. designed an earthquake alarm system using wireless sensors, which operates more quickly than other systems. The key to improving the system's overall efficiency lies in the strategic placement of the sensors.

The effectiveness of earthquake early warning (EEW) systems is greatly influenced by the accuracy of P-wave arrival detection. EEW's automated P-wave selecting algorithms have had issues with incorrectly picking up noise and missing P-waves. A convolution neural network (DPick)-based automatic algorithm has been developed (Yanwei, 2021).

Sultanov et al. (2020) have conducted extensive studies on the Strength of underground pipelines under seismic effects.

Alphonsa A et al. introduced a method wherein P-waves detected by sensors are transmitted through a Zigbee transmitter to a Zigbee receiver that is integrated into the Internet of Things (IoT). The IoT subsequently forwards warning messages to smartphones.

*System structure*

The architecture of an early warning system was developed based on IoT technology and fuzzy system with respect to expert knowledge and international researchers. These systems with P-wave recognition could shut-down gas, electric network before the destructive earthquake wave occurs. The system is an advanced version of early warning system discussed in the literature. The system consisted of five sensors measure multi parameters described in sensor section. the data is uploaded to the cloud through multi-hop wireless communication from the data aggregator. After local and server validation, this data will be processed in cloud server and after that system executes the relevant scenarios and Operational sensors are given operational commands (Fig. 1).

Utilizing early warning systems prior to the occurrence of earthquakes can significantly reduce human errors. Hein Hilary posits that over 85 % of safety accidents in enterprises are attributed to unsafe human behavior. Numerous accident investigations corroborate these findings. Therefore, monitoring unsafe behaviors of employees is crucial within an enterprise accident early warning system.

The acquisition of real-time accelerograms based on data from three axes facilitates the early detection of the primary seismic wave (P-wave), which is the first seismic wave that occurs following an earthquake and features a significant compression component.

The P-wave travels faster than other seismic waves but is less hazardous because it is a compression wave, typically resulting in minimal damage. In contrast, the S wave moves at approximately half the speed of the P wave. As a transverse wave, it induces dangerous shaking. R/L waves, which are surface waves generated at the epicenter through the combination of P and S waves, propagate through the Earth's crust until they dissipate their energy. R/L waves create horizontal and vertical oscillations in structures and are considered damaging waves. They travel more slowly than other seismic waves, at about one-third the speed of P waves. Earthquake guard systems utilize this characteristic of R/L waves to „predict“ earthquakes before they are felt by individuals (Aki, 2004).

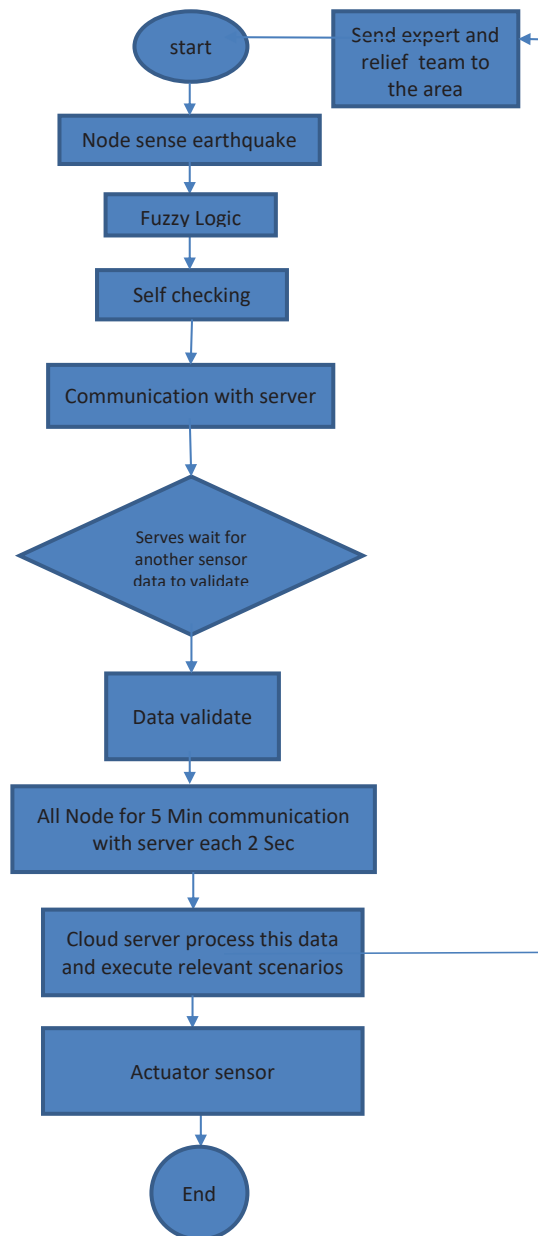

Fig. 1. Flow chart system

The suggested IoT-based solution to manage disaster effectively contains three steps, which is presented in Fig. 2:

1. Information Gathering sensors and Actuator sensors;
2. Information Transmission;
3. Information Processing and Decision making.

*Information gathering sensors and actuator sensors*

This section divided in 2 parts, section one is about the kind of sensor which is getting information, and section two is about actuator sensor to execute cloud server commands.

*Receivers*

This sector is also one of the most significant parts, because the procedure of data processing is the same as the eye system. It is necessary to measure the exact data used in the decision-making stage.

Each node is made up various hardware devices and consists five sensors; PGA (peak

ground accelerator) sensor, fire detection sensor, temperature sensor, humidity sensor GPS sensors to monitor real data (Fig. 3).

*Actuator sensors*

Actuator sensors should be settled upon the gas distribution and electrical substations. Then the server sends the signal to the actuator sensor to disconnect or connect the area controlling by each sensor (Fig. 4).

The expert monitor the site after the earthquake and restore the area, where has not been serious damage.

*Receiver Sensor position*

To establish an effective earthquake monitoring network, it is essential to install a sufficient number of sensors and strategically distribute them across the area to be monitored. According to Mojarab et al. (2017) the sensors should be spaced no more than 10 kilometers apart to accurately detect seismic activity (Fig. 5). Our network covers an area of 1,350 km<sup>2</sup> (30 km × 45 km) and consists of 54 sensor nodes.

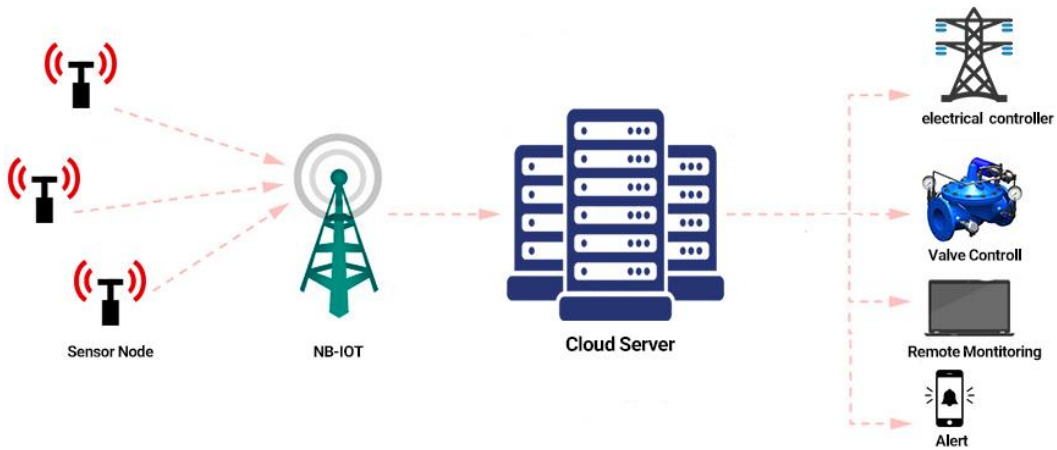

Fig. 2. IoT early warning system architecture

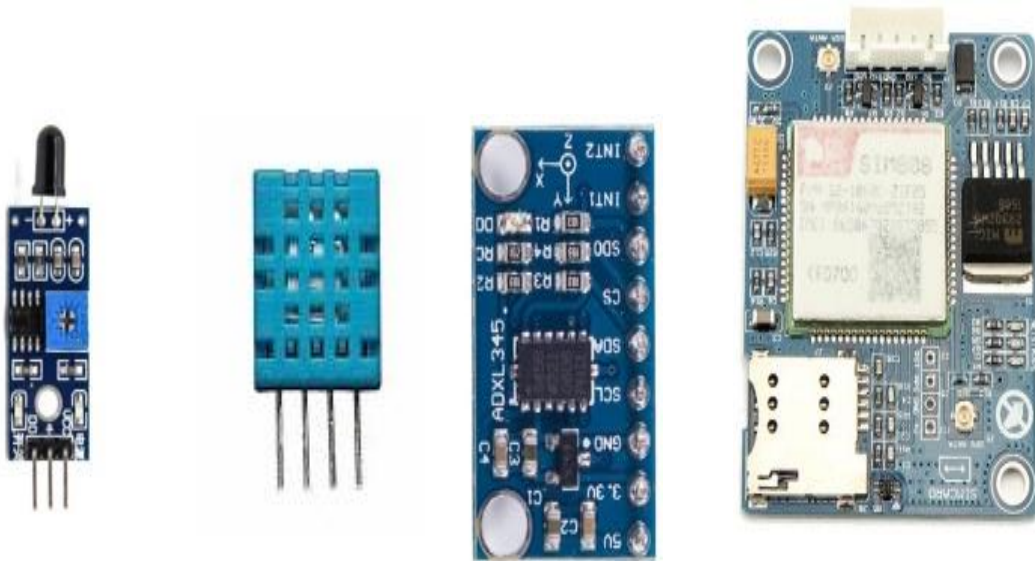

Fig. 3. Receiver Sensors

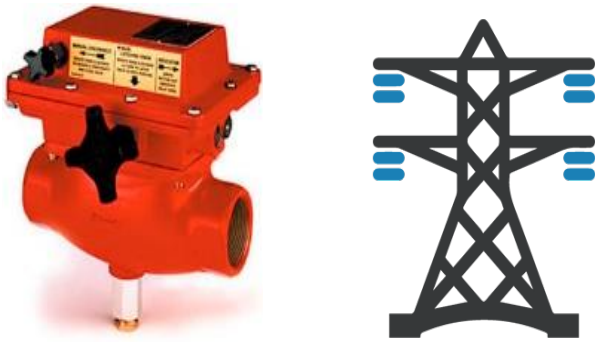

Fig. 4. Gas and Electrical Actuator

These 54 sensor nodes have been carefully positioned throughout Tehran based on a combination of seismic risk assessments and population density. Locations near the active fault lines, such as the North Tehran Fault and Rey Fault, were prioritized, given their heightened risk of significant seismic events. Critical urban infrastructures, including gas pipelines, electricity grids, and densely populated areas, were also key factors in the selection of sensor sites. This ensures both comprehensive monitoring and early warning capabilities for high-risk zones.

In alignment with the Tehran Fault Scenario, the sensors in these specified locations (as illustrated in Fig. 5, which includes a detailed map of the sensor network layout) transmit seismic data to the central server. Additionally, sensors placed outside the predefined fault zones are designated to detect unknown fault activities, ensuring that potential new seismic threats are also monitored.

*Validating input data*

The system is equipped with a self-validation device to check sensor value to decrease the number of errors in the system and prevent from a huge and inefficient data. When the PGA value is more than the defined value (0.1 G) in the system, the data is transmitted to server and sensor will be connected to cloud server directly for 5 minutes every 2 seconds. The next is to check the data received at the same time from at least 2 nearest nodes. This double check reduces the fake alarm and improve accuracy in the system.

*Information Transmission*

Transmission layers are a fusion of various networks. It securely transfers the information obtained from the perceptual layer to the application layer or vice versa.

IoT transmission has developed fast and created different ways to communicate between things to things or things to a human. We compare the best framework in transmission in Table 1, then choose a better transitions framework for the research concept.

The objective of this research is to identify a secure, low-power, stable, and cost-effective communication technology suitable for an IoT-based earthquake early warning system. After careful evaluation of the available technologies, Narrowband IoT (NB-IoT) is selected as the most appropriate choice for this project. Its advantages include extended transmission range, low power consumption, and high operational efficiency.

Given the broader context of the Internet of Things, early warning systems can be considered critical components of smart city infrastructures. Moreover, utilizing NB-IoT eliminates the need for

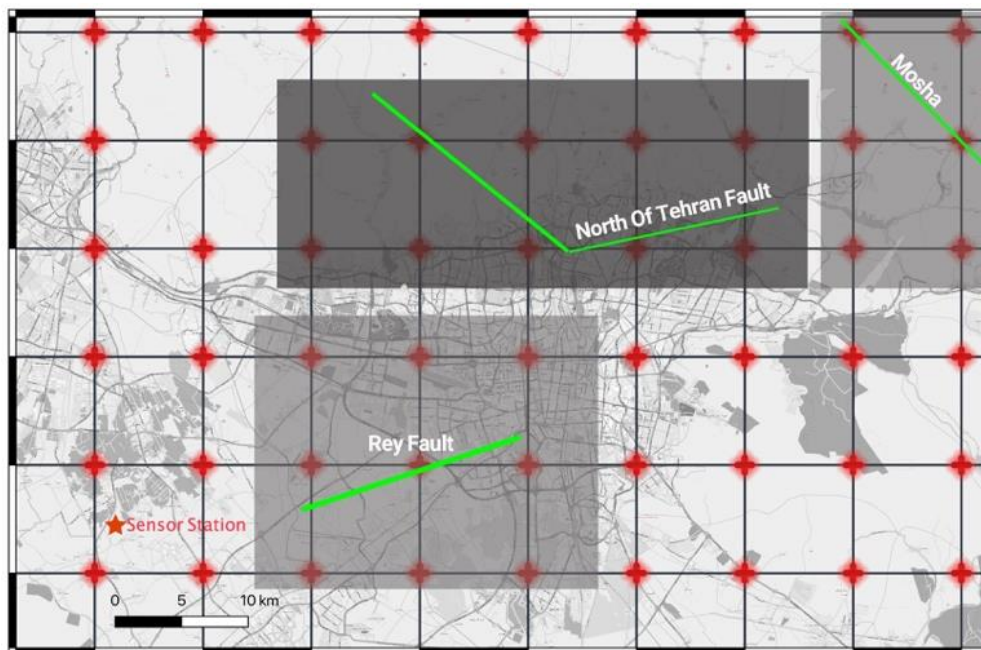

Fig. 5. Sensor position

Table 1. Transport layer (Chen et al., 2017; Raza, 2017)

Technology	Frequency	Data Range	Transmission Range	Date rate (up and down link)	Power Usage (energy Consumption)	Operating life (battery)	Cost
<b>2G/3G</b>	Cellular Bands	10 Mbps	35 Km	No limitation	High	4–8 hours 36 days (idle)	High
<b>Bluetooth 4 LE</b>	2.4 Ghz	24 Mbps	50 m	No limitation	Low	Hours	Low
<b>802.15.4</b>	subGhz, 2.4 GHz	250 kbps	200 m	No limitation	Low	Up to 4 years	Low
<b>LORA</b>	SubGhz, 2.4 GHz (868/915 MHz)	More than 50 kbps	2–10 km	EU: 30 bps – 50 kbps US:100–900 kbps	Low	10–20 years (idle) / 120 hours (communication)	Medium
<b>LTE Cat 0/1</b>	Cellular Bands	1–10 Mbps	Several kilometers	Up to 1 MBPs	Medium	2–3 hours (communication) / 12 days (idle)	High
<b>NB-IoT</b>	Cellular Bands (180 KHZ)	0.1–1 Mbps	10–15 km	150 kbps (NB) up to 1 mbps	Medium		High
<b>SIGFOX</b>	subGhz	< 1 kbps	Several kilometers	4x8 b/day (down) 100 bps (up)	Low	10–20 years (idle) / 120 hours (communication)	Medium
<b>WiMax</b>	subGhz	34 Mbps – 1 Gbps	40 km	No limitation	Low	hours	Low
<b>WIFI</b>	subGhz, 2.4 Ghz, 5 Ghz	0.1–54 Mbps	up to 10 m	No limitation	Medium	4–8 hours 50 days (idle)	Low
<b>ZigBee</b>	2.4 Ghz	250 kbps	10–500 m	No limitation	Low	Up to 2 years	Medium

a separate communication system, thus significantly reducing maintenance costs. This integration will facilitate timely alerts and improve the overall effectiveness of the early warning system in Tehran.

*Information processing and execute command by using Fuzzy Logic*

Due to the severe damages caused by previous earthquakes, collision of gas and electricity network, or gas leakage led to the secondary explosions and damages. This study aims to reduce this type of damage by using the defined fuzzy system.

To detect damages of the gas and electric network, fuzzy logic methods were used with inclusion of four criteria, of gas pipeline, gas compressor, distribution circuits, electric boost station as shown in Fig. 6.

*Input criteria*

The values received from the sensors are transformed into fuzzy sets like 'Low probability risk failures', 'Medium probability risk failures', 'High probability risk failures', based on HAZUS methodology (FEMA, 1999) (Table 2).

*Gas network*

HAZUS methodology is divided in two vulnerable sections of the gas network. Section one is about the compressor station and section two is about gas pipeline. Both of these components are seismically vulnerable. It is worth mentioning that their probable failure can cause fire disasters. So that, this part

discusses stages based on these boundaries (FEMA, 1999).

The fuzzy scenarios defined are appropriate to the conditions of the gas and electricity facilities in Tehran. Compressor stations are regarded to be an Anchored of Compressor Stations.

The damage States Definition in Fig. 7 is based on the HAZUS methodology for Compressor Stations; and since HAZUS has not determined an accurate level of failure for gas pipeline, the damage States Definitions for gas pipelines according to (Lanzano et al., 2014) is displayed in Fig. 8. The membership function for Gas Compressor Stations and gas pipelines shown in Figs. 9–10.

*Electrical network*

Electrical network vulnerability in HAZUS methodology is also divided in two:

1. Distribution Circuits;
2. Electric boost station.

Damage state of Distribution Circuits (contain poles, wires, in-line equipment and utility-owned equipment at customer sites) and Low voltage Substations power (34 kV to 150 kV) shown in Figs. 11–12. The membership function for Distribution circuits and Substations electric shown in Figs. 13–14. Low voltage (34 kV to 150 kV) are regarded for substation power for Tehran city.

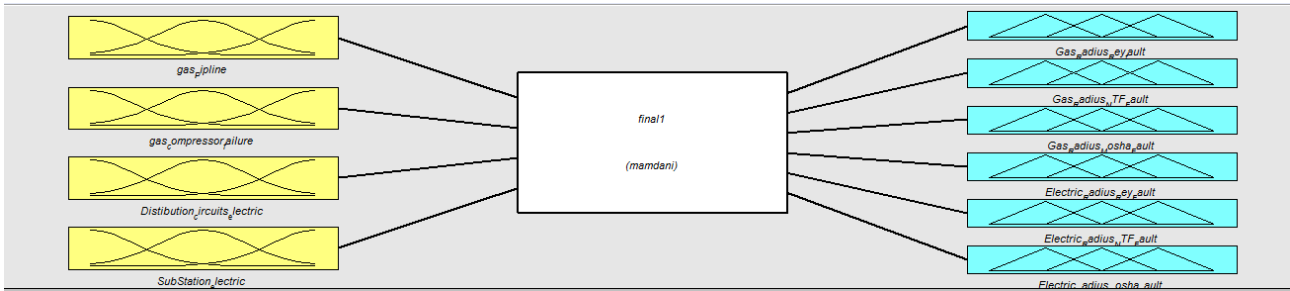

Fig. 6. Fuzzy system of Early warning system

Table 2. Value of linguistic variable

Criteria Variable	Low probability risk failures	Medium probability risk failures	High probability risk failures
Gas Compressor Stations	Acceleration 0-0.238	Acceleration 0.238-0.34	Acceleration 0.34-1.0
Gas Pipeline	Acceleration 0-0.406	Acceleration 0.406-0.58	Acceleration 0.58-1.0
Distribution circuits electric	Acceleration 0-0.28	Acceleration 0.28-0.4	Acceleration 0.4-1.0
Low voltage Substations	Acceleration 0-0.203	Acceleration 0.203-0.29	Acceleration 0.29-1.0

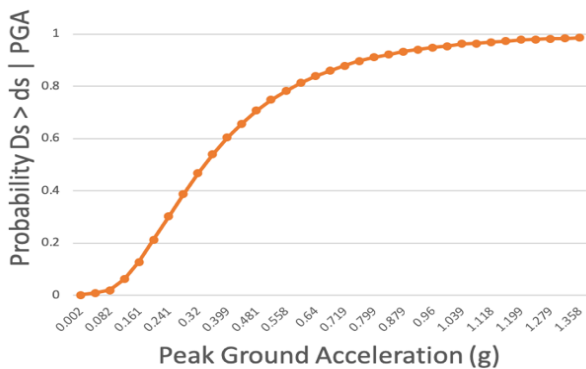

Fig. 7. Fragility Curves for Compressor Stations with Anchored Components (FEMA, 1999)

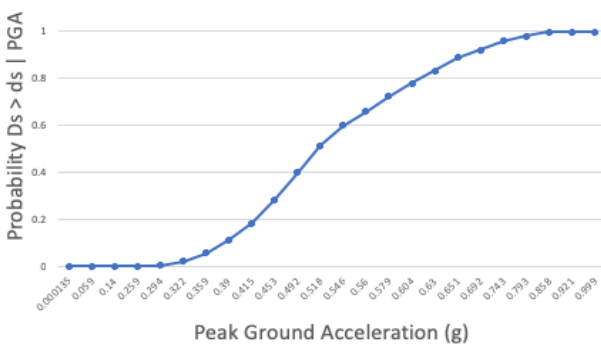

Fig. 8. Fragility curves for gas pipelines (Lanzano et al., 2014)

**Output criteria**

Shut-down and alarm command are the output of this system and transformed into fuzzy sets like "Minor damage", "Moderate Damage", Extensive Damage", "Complete Damage" (Table 3–4). The Rules of this system.

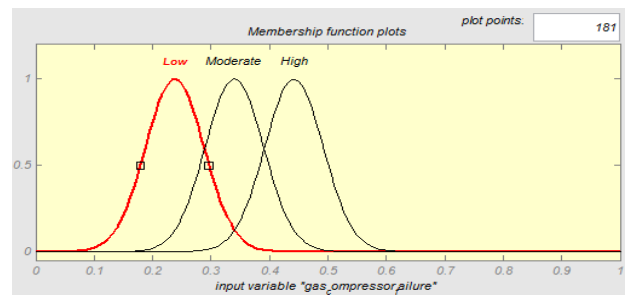

Fig. 9. Membership function Gas Compressor Stations

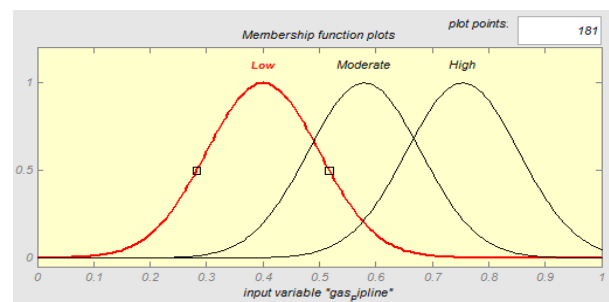

Fig. 10. Membership function gas Pipeline

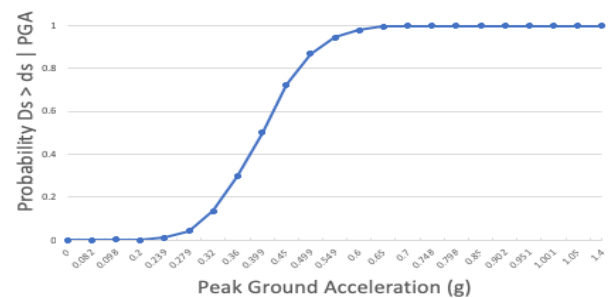

Fig. 11. Fragility curves Distribution Circuits (FEMA, 1999)



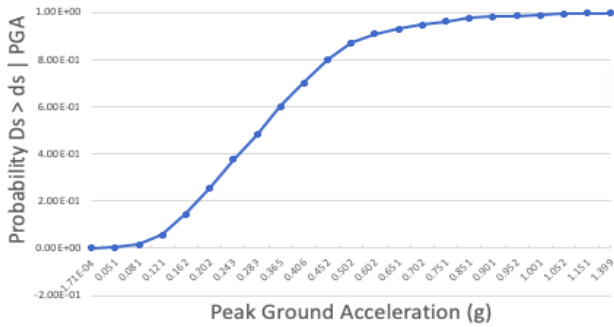

Fig. 12. Fragility curves for Low voltage Substations (FEMA, 1999)

Design base on expert opinion. Membership function shut-down commands shown in Figs. 15–22.

**Case Study: Tehran City**

In the Middle East, Tehran as Iran capital, is the second-largest metropolitan region with a population about 8.5 million. This city is a high seismic hazard area, which can cause significant damages to economic, social and political sectors in the event of an earthquake (Fig. 23). Hence, it is important to use early warning system to prevent secondary destructive damage. Furthermore,

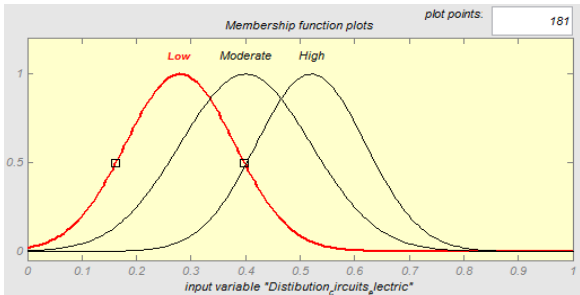

Fig. 13. Membership function Distribution circuits

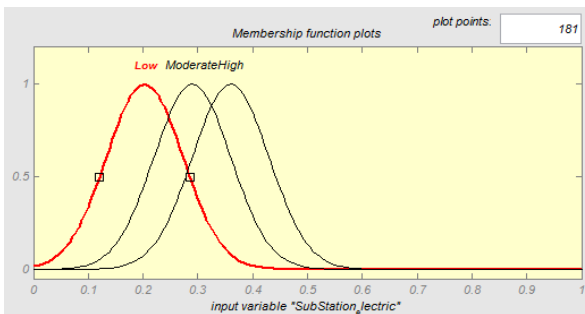

Fig. 14. Membership function Substations electric

**Table 3. Shut-Down Command Gas**

Linguistic Variables	Define	Range
R1	Minor area	0–6
R2	Moderate area	8–14
R3	Major area	16–22
R4	Complete area	24–30

**Table 4. Shut-Down Command Electric**

Linguistic Variables	Define	Range
R1	Minor area	0–8
R2	Moderate area	10–16
R3	Major area	18–24
R4	Complete area	26–30

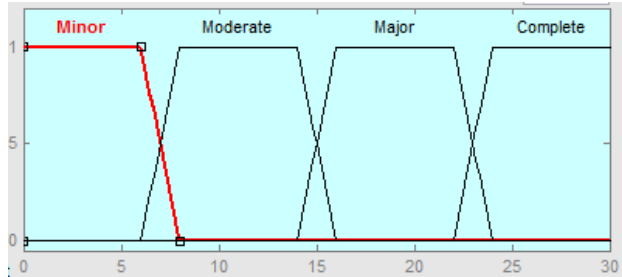

Fig. 15. Membership function shut-down command-gas-Rey fault

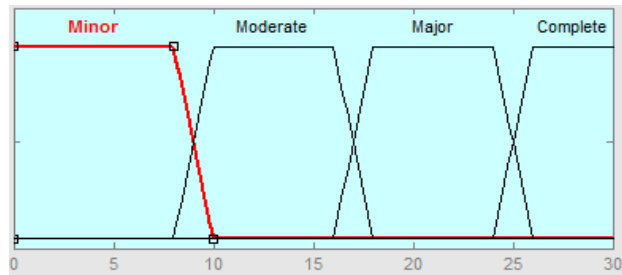

Fig. 16. Membership function shut-down command-electric-Rey fault

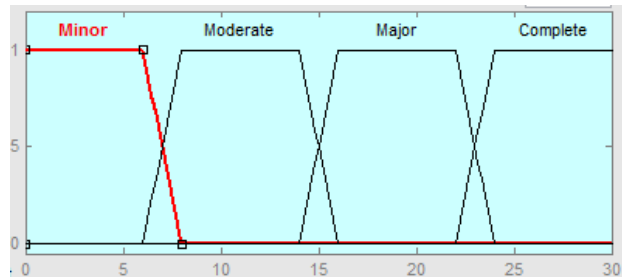

Fig. 17. Membership function shut-down command-gas-North of Tehran fault (NTF)

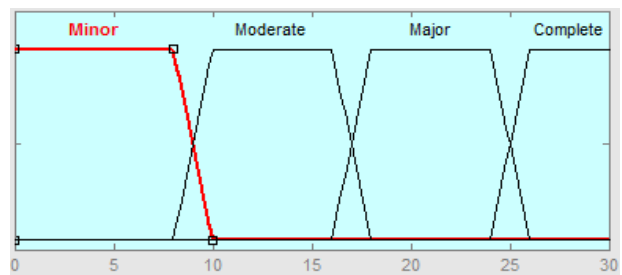

Fig. 18. Membership function shut-down command-electric-North of Tehran fault (NTF)

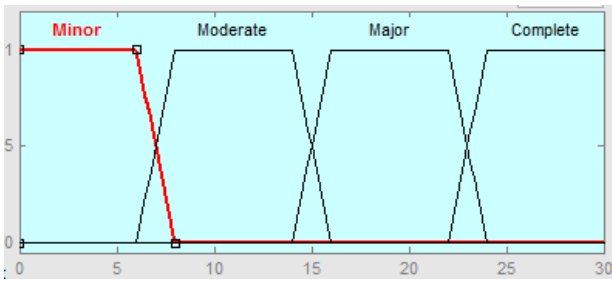

Fig. 19. Membership function shut-down command-gas-Mosha fault

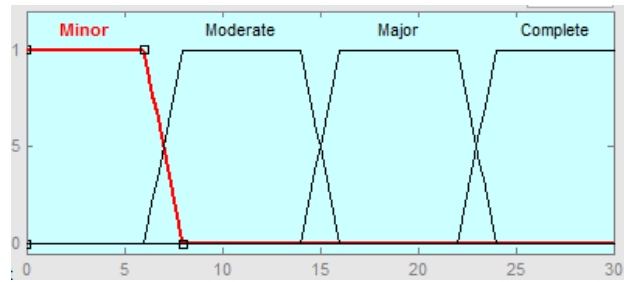

Fig. 21. Membership function shut-down command-gas-undefined fault

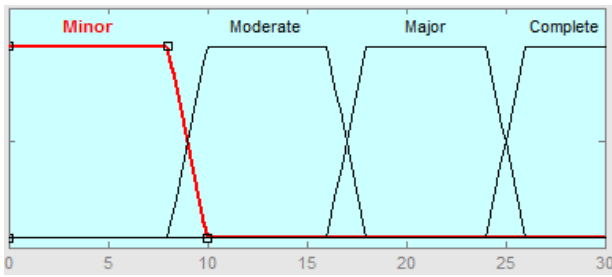

Fig. 20. Membership function shut-down command-electric-Mosha fault

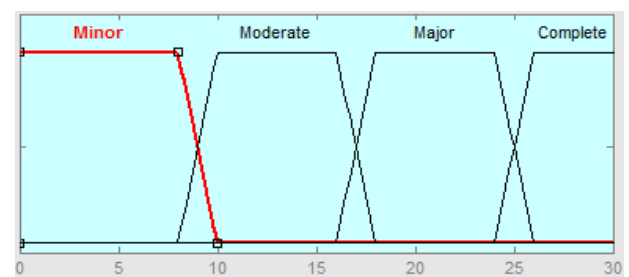

Fig. 22. Membership function shut-down command-electric-undefined fault

there exists more than 65,000 gas riser and approximately 100 km long gas pipeline and make it impossible to manage the city in a traditional way in critical time.

Cooperating with the Tehran Municipality in 2000, the International Co-operation Agency of Japan (JICA) developed the Tehran earthquake damage reduction program. The agency evaluated the

different kinds of earthquake events in Tehran and their damage and casualties.

In Table 5, more thorough data on the characteristics of the faults is presented (JICA)

*Rules*

Tehran, it is located on three major faults, "NTF", "Ray" and "Mosha". If they are activated, it can Bring irreparable damage to the city (JICA).

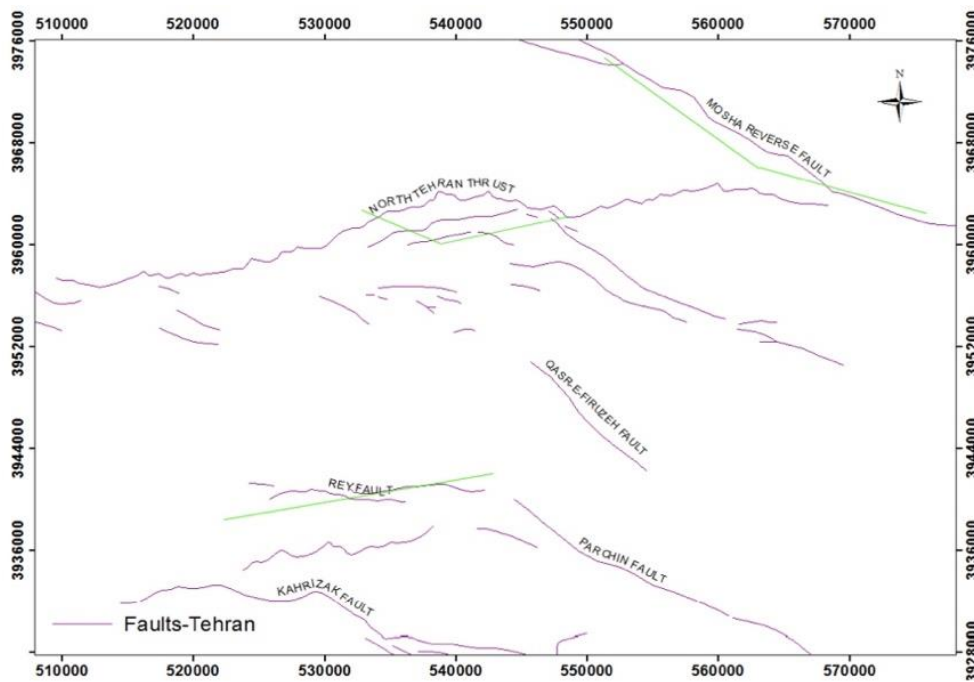

Fig. 23. Fault around the region of Tehran (JICA, 2000)

The final commands issued by the system are defined based on the scenario faults mentioned and for the areas outside the scenario faults, the unknown fault scenario will be implemented. The number of scenarios and rules defined for post-earthquake loss control in Tehran are 72, the scenarios being defined based on the opinion of experts.

These values set like "Minor or R1", "Moderate or R2", "Major or R3", "Complete or R4" (Table 6–7). These functions indicate how radically the gas or electricity should be shut-down command base on the failure level caused and the Maximum amount of PGA produced from each fault. According to these outputs, actions alert and disconnect the valve of gas and electricity executed to prevent secondary destructive damage

Table 5. Name of Tehran Fault with Detail (JICA)

Name	Magnitude (Mw)	Fault length (km)
Mosha fault	7.3	68
North of Tehran fault (NTF)	7.3	90
Rey fault	6.6	20

*Laboratory study*

In the laboratory model, an ADXL345 sensor was utilized to detect seismic activity, while a DHT11 sensor was employed to monitor environmental temperature and humidity. Data from these sensors were transmitted to the server via an Arduino Uno module. The server, developed using Node.js, processes this data and executes the appropriate scenario based on predefined fuzzy logic criteria (Fig. 24–25).

The result of this report was that after creating artificial waves with a vibrating device, the

seismograph sensor detects the waves in less than 4 seconds, and then cuts off the gas and electricity taps in less than 6 second, and also lights up the warning light. This model was made only to test and implement the accuracy of the sensors.

One of the main differences between this model and the previous models is that most models issue warnings a few seconds earlier than the destructive wave, which often have a monitoring aspect. But in this model, due to the dispersion of seismograph sensors in the city, it detects the initial wave in less than 4 seconds, and based on the risk of JICA models (JICA) and the distance from the epicenter to the lifeline, first the level of damage to the gas and electricity network It is predicted and then the relevant scenario is implemented based on that.

**Results**

Using IoT technology and a fuzzy algorithm, this system detects seismic waves and makes decisions based on predefined fuzzy scenarios in less than 10 seconds, issuing executive commands to disconnect the city’s critical lifelines to prevent secondary damage. According to the models mentioned in the Literature Review section of this research, the proposed model demonstrates acceptable results.

Also, in the first chapter of the JICA studies, which is the only documented source of Seismic hazard assessment and enforcement measures to prevent secondary hazards in Tehran’s metropolitan area, it identified the radius that gas and electricity lines would have to be shut-down as scenario faults became active. Using the results of these studies, the performance of the fuzzy system defined in Table 8 is investigated which shows acceptable results (JICA). In addition to gas and electricity transmission lines, the proposed model consider the gas pressure boost compressor stations as

Table 6. Shut-Down - Gas Network

Fault Name	Damage to gas pipeline Damage to compressor station			
		Low	Medium	High
Rey	Low	R1	R3	R3
	Medium	R3	R3	R3
	High	R3	R3	R4
NTF	Low	R1	R3	R3
	Medium	R3	R3	R3
	High	R3	R3	R4
Mosha	Low	R1	R2	R3
	Medium	R2	R2	R3
	High	R3	R3	R4
Undefined	Low	R1	R2	R3
	Medium	R2	R3	R3
	High	R3	R3	R4

Table 7. Shut-Down - Electric Network

Fault Name	Damage to electric network Damage to electric station			
		Low	Medium	High
Rey	Low	R1	R3	R3
	Medium	R3	R3	R3
	High	R3	R3	R4
NTF	Low	R1	R3	R3
	Medium	R3	R3	R3
	High	R3	R3	R4
Mosha	Low	R1	R2	R3
	Medium	R2	R2	R3
	High	R3	R3	R4
Undefined	Low	R1	R2	R3
	Medium	R2	R3	R3
	High	R3	R3	R4



Fig. 24. Laboratory Setup for Testing the Accuracy of the IoT-Based Earthquake Early Warning System with Fuzzy Logic Integration

well as power pressure boost station in the defined fuzzy system.

**Conclusion**

In the face of inevitable seismic events, the unpredictability of earthquakes presents significant challenges for disaster preparedness and response. An effective early warning system is essential for mitigating damage to infrastructure, safeguarding assets, and preserving human lives. This study focused on Tehran, a city with high seismic potential and dense gas and electric utility networks, highlighting its unique vulnerabilities. The proposed IoT-based early warning system, integrated with

fuzzy logic, represents a significant advancement in disaster management strategies. By offering real-time data processing and operational command capabilities, this system addresses critical delays often associated with traditional methods, particularly during the crucial early hours following an earthquake.

The results of this research demonstrate that the proposed system yields acceptable outcomes when compared to the comprehensive Seismic Hazard Assessment of Tehran (JICA). Within less than 10 seconds, based on the predicted level of damage to the city’s lifeline infrastructure, the system issues

```

Arduino Uno
ada345.ino
1 #include "Wire.h" // This library allows you to communicate with I2C devices.
2 const int MPU_ADDR = 0x68; // I2C address of the MPU-6050. If ADDR pin is set to HIGH, the I2C address will be 0x69.
3 int16_t accelerometer_x, accelerometer_y, accelerometer_z; // variables for accelerometer raw data
4 int16_t gyro_x, gyro_y, gyro_z; // variables for gyro raw data
5 int16_t temperature; // variables for temperature data
6 int buzzer = 8; //buzzer pin
7 int gas = 10; //gas pin
8 int deltax,deltay,deltaz;
9 int a[150] = {0};
10 int a2[150] = {0};
11 int a3[150] = {0};
12 int i1=0;
13 char tmp_str[7]; // temporary variable used in convert function
14 char* convert_int16_to_str(int16_t i) { // converts int16 to string. Moreover, resulting strings will have the same length in the debug monitor.
15     sprintf(tmp_str, "%6d", i);
16     return tmp_str;
17 }
18 void setup() {
19     pinMode(buzzer, OUTPUT);
20
21     pinMode(gas, OUTPUT);
22     digitalWrite(gas, HIGH);
23     Serial.begin(9600);
24     Wire.begin();
25     Wire.beginTransmission(MPU_ADDR); // Begins a transmission to the I2C slave (GY-521 board)
26     Wire.write(0x6B); // PWR_MGMT_1 register
27     Wire.write(0); // set to zero (wakes up the MPU-6050)
28     Wire.endTransmission(true);
29 }
30 void loop() {
31     Wire.beginTransmission(MPU_ADDR);
32     Wire.write(0x3B); // starting with register 0x3B (ACCEL_XOUT_H) [MPU-6000 and MPU-6050 Register Map and Descriptions Revision 4.2, p.40]
33     Wire.endTransmission(false); // the parameter indicates that the Arduino will send a restart. As a result, the connection is kept active.
34     Wire.requestFrom(MPU_ADDR, 7*2, true); // request a total of 7*2=14 registers
35
36     // "Wire.read()<<8 | Wire.read();" means two registers are read and stored in the same variable
37     accelerometer_x = Wire.read()<<8 | Wire.read(); // reading registers: 0x3B (ACCEL_XOUT_H) and 0x3C (ACCEL_XOUT_L)
38     accelerometer_y = Wire.read()<<8 | Wire.read(); // reading registers: 0x3D (ACCEL_YOUT_H) and 0x3E (ACCEL_YOUT_L)
39     accelerometer_z = Wire.read()<<8 | Wire.read(); // reading registers: 0x3F (ACCEL_ZOUT_H) and 0x40 (ACCEL_ZOUT_L)
40     temperature = Wire.read()<<8 | Wire.read(); // reading registers: 0x41 (TEMP_OUT_H) and 0x42 (TEMP_OUT_L)
41     gyro_x = Wire.read()<<8 | Wire.read(); // reading registers: 0x43 (GYRO_XOUT_H) and 0x44 (GYRO_XOUT_L)
42     gyro_y = Wire.read()<<8 | Wire.read(); // reading registers: 0x45 (GYRO_YOUT_H) and 0x46 (GYRO_YOUT_L)
43     gyro_z = Wire.read()<<8 | Wire.read(); // reading registers: 0x47 (GYRO_ZOUT_H) and 0x48 (GYRO_ZOUT_L)
44
45     // print out data
46     Serial.print("ax = "); Serial.print(convert_int16_to_str(accelerometer_x));

```

Fig. 25. Arduino Coding for Wave Detection and Data Transmission to Cloud Server

**Table 8. Compare Results of JICA and IoT-Fuzzy Early Warning Model**

<b>Fault</b>	<b>Maximum PGA (G) (JICA)</b>	<b>Network</b>	<b>IoT-Fuzzy early warning model shut down command</b>	<b>Shut-down command by JICA (JICA)</b>
<b>Rey</b>	0.5 G	Gas	19 km	18 km
<b>Rey</b>	0.5 G	Electric	23 km	20 km
<b>NTF</b>	0.3 G	Gas	13 km	10 km
<b>NTF</b>	0.3 G	Electric	16 km	12 km
<b>Mosha</b>	0.1 G	Gas	4 km	2 km
<b>Mosha</b>	0.1 G	Electric	6 km	0 km

disconnection commands, effectively preventing secondary destructive incidents. This rapid response capability marks a key improvement in reducing the overall impact of seismic events in highly vulnerable urban environments.

Several limitations to this study should be acknowledged. First, the system’s effectiveness is largely contingent on the reliability and accuracy of the sensors. Over time, environmental factors, wear, or earthquake-related damage may degrade sensor performance, potentially leading to false alarms or failure to detect seismic events. The use of industrial-grade sensors is recommended for more accurate detection of earthquake waves. Moreover, maintaining and managing a large network of sensors poses significant logistical challenges, necessitating regular maintenance to ensure optimal performance.

Second, the and electric networks, is essential to prevent unauthorized access or potential cyber-attacks. To enhance security, block-chain technology could be integrated to safeguard the integrity of the network and the data it processes.

Future research directions should focus on several key areas to enhance the proposed system. First, integrating additional machine learning techniques could improve predictive accuracy and real-time responsiveness, offering more refined decision-making models. Second, applying this model to

other cities with diverse seismic risks would enable comparative analyses, revealing strengths and weaknesses across different urban environments and contributing to the refinement of disaster response strategies. Third, incorporating advanced sensors — such as environmental sensors, satellite imagery, or structural health monitoring — could further improve the system’s ability to assess and respond to seismic risks. Lastly, exploring the socio-economic impacts of implementing such systems would provide insight into the long-term value and benefits, particularly in terms of cost savings and the reduction of human and material losses during seismic events.

In conclusion, the proposed IoT and fuzzy logic integration represents a promising approach to enhance earthquake preparedness and response in urban environments. By addressing current limitations and exploring new research avenues, future studies can build upon this work to develop more comprehensive solutions that ensure the safety and resilience of communities facing the ever-present threat of earthquakes.

Issue of data privacy and security must be addressed due to the extensive data collection by IoT devices. Protecting sensitive information, particularly in the context of critical infrastructure like gas.

## References

- Abdalzaher, M. S., Krichen M., Yiltas-Kaplan, D., Dhaou, I. B., and Adoni, W. Y. H. (2023). Early Detection of Earthquakes Using IoT and Cloud Infrastructure: A Survey. *Sustainability*, Vol. 15, p. 11723. DOI: 10.3390/su151511713.
- Ahn, J. -K., Kim, T. -H., and Koo, H. (2024). Design for Optimized Public Safety and Earthquake Disaster Mitigation With IoT. *IEEE Access*, Vol. 12, pp. 43485-43494, DOI: 10.1109/ACCESS.2024.3379729.
- Ahumada, A., Altunkaynak, A., Ayoub, A. (2015). Fuzzy logic-based attenuation relationships of strong motion earthquake records. *Expert Systems With Applications*, Vol. 42, Issue 3, pp. 1287–1297. DOI: 10.1016/j.eswa.2014.09.035.
- Aki, K. and Richards, P. (2004). *Quantitative Seismology, 2 University Science Books*, Sausalit.
- Atzori, L., Iera, A., and Morabito, G. (2010). The Internet of Things: A survey. *Computer Networks*, Vol. 54, Issue 15, pp. 2787-2805. DOI: 10.1016/j.comnet.2010.05.010.
- Azizzadeh, F., Babapour H., Akhavan, M., Azizzadeh, S., Khatoon V. D. T., and Hosseini, A. (2022). Expectations and Organizational Realities: The Relationship between Person and Organization. *The International Journal of Interdisciplinary Organizational Studies*, Vol. 17, Issue 1, pp. 23-34. DOI: 10.18848/2324-7649/CGP/v17i01/23-34.
- Buzduga, C., Graur, A., Ciufudean, C., and Vlad, V. (2015). System for the detection earthquake victims construction and principle of operation. *New Developments in Circuits, Systems, Signal Processing, Communications and Computers*, pp. 110-115.
- Chen, M., Miao, Y., Hao, Y., and Hwang, K. (2017). Narrow Band Internet of Things. *IEEE Access*, Vol. 5, pp. 20557-20577. DOI: 10.1109/access.2017.2751586.
- Database, E. O. C. I. D. (2019). Total number of deaths as a result of natural disasters. [online] Available at: <https://ourworldindata.org/natural-disasters> [Date accessed April 25, 2024].
- Doi, K. (2011). The operation and performance of Earthquake Early Warnings by the Japan Meteorological Agency. *Soil Dynamics and Earthquake Engineering*, Vol. 31, Issue 2, pp. 119–126. DOI: 10.1016/j.soildyn.2010.06.009.
- Duhamel, C., Santos, A. C., Brasil, D., Châtelet, E., and Birregah, B. (2016). Connecting a population dynamic model with a multi-period location-allocation problem for post-disaster relief operations. *Annals of Operations Research*, Vol. 247, pp. 693–713. DOI: 10.1007/s10479-015-2104-1.
- Erdik, M., Fahjan, Y., Ozel, O., Alcik, H., Mert, A., and Gul, M. (2003). Istanbul Earthquake Rapid Response and the Early Warning System. *Bulletin of Earthquake Engineering*, Vol. 1, pp. 157–163. DOI: 10.1023/A:1024813612271.
- FEMA (1999) HAZUS Earthquake Loss Estimation Methodology. Technical Manual, Prepared by the National Institute of Building Sciences for the Federal Emergency Management Agency, Washington DC.
- Foghahaayee, H. N., Menhaj, M. B., and Torbatib, H. M. (2014). Fuzzy decision support software for crisis management in gas transmission networks. *Applied Soft Computing*, Vol. 18, pp. 82–90. DOI: 10.1016/j.asoc.2014.01.019.
- Fumio, Y. (2001). Seismic monitoring and early damage assessment systems in Japan. *Progress in Structural Engineering and Materials*, Vol. 3, Issue 1, pp. 66-75. DOI: 10.1002/pse.75.
- Hoshiba, M., Iwakiri, K., Hayashimoto, N., Shimoyama, T., Hirano, K., Yamada, Y., Ishigaki, Y., and Kikuta, H. (2011). Outline of the 2011 off the Pacific coast of Tohoku Earthquake (Mw 9.0) — Earthquake Early Warning and observed seismic intensity. *Earth, Planets and Space*, Vol. 63? No 7. DOI: 10.5047/eps.2011.05.031.
- Hoshiba, M. and Ozaki, T. (2014). Earthquake Early Warning and Tsunami Warning of the Japan Meteorological Agency, and Their Performance in the 2011 off the Pacific Coast of Tohoku Earthquake M9. In F. Wenzel & J. Zschau (Eds.), *Early Warning for Geological Disasters: Scientific Methods and Current Practice*, pp. 1–28. Springer Berlin Heidelberg. DOI: 10.1007/978-3-642-12233-0\_1.
- Jahanbakhshian, P., Akhavan, M., Rezapour, A., and Ashrafi, N. (2020). The relationship between organizational commitment and organizational performance with respect to knowledge sharing (Case study: Selected Project-based organizations). *Turkish Journal of Computer and Mathematics Education (TURCOMAT)*, Vol. 12, Issue 13, pp. 4906-4916.
- Jianshe, D., Shuning W., and Xiaoyin, Y. (1994). Computerized support systems for emergency decision making. *Annals of Operations Research*, Vol. 51, Issue 7, pp. 313–325. DOI: 10.1007/BF02048553.
- JICA (2000). The study on seismic microzonation of the Greater Tehran Area in the Islamic Republic of Iran.
- Lanzano G., Salzano E., Santucci de Magistris F., and Fabbrocino G. (2014). Seismic vulnerability of gas and liquid buried pipelines. *Journal of Loss Prevention in the Process Industries*, Vol. 28, pp. 72–78. DOI: 10.1016/j.jlp.2013.03.010.
- Nord, J. H. , Koohang, A., and Paliszkieviczc, J. (2019). The Internet of Things: Review and theoretical framework. *Expert Systems With Applications*, Vol. 133, pp. 97–108. DOI: 10.1016/j.eswa.2019.05.014.
- Nokhbatolfoghahaayee, H., Menhaj, M. B., and Shafiee, M. (2010). Fuzzy decision support system for crisis management with a new structure for decision making. *Expert Systems with Applications*, Vol. 37, Issue 5, pp. 3545–3552. DOI: 10.1016/j.eswa.2009.10.011.

- Katayama, T. (2004). Earthquake disaster risk mitigation before and after the 1995 Kobe earthquake. *13th world conference on earthquake engineering*, Vancouver, B.C., Canada, No. 5005.
- Lee, E. K., Maheshwary, S., Mason, J., and Glisson, W. (2006). Decision support system for mass dispensing of medications for infectious disease outbreaks and bioterrorist attacks. *Annals of Operations Research*, Vol. 148, pp. 25–53. DOI: 10.1007/s10479-006-0087-7.
- Maglogiannis, C. D. I. (2012). Bringing IoT and Cloud Computing towards Pervasive Healthcare. Sixth International Conference on Innovative Mobile and Internet Services in Ubiquitous Computing, Palermo, Italy, 2012, pp. 922-926. DOI: 10.1109/IMIS.2012.26.
- Mali, J. R. and Kumbhar, M. S. (2016). Wireless Sensor Based Landslide Detection. *International Journal of Latest Trends in Engineering and Technology*, Vol. 7, Issue 1. DOI: 10.21172/1.71.066.
- Manshoori, M. R. (2011). Evaluation of Seismic Vulnerability and Failure Modes for Pipelines. *Procedia Engineering*, Vol. 14, pp. 3042–3049. DOI: 10.1016/j.proeng.2011.07.383.
- Mojarab, M., Shahvar, M. P., Poorveis, M., Norozi, N., and Asadi, Z. (2017). Feasibility study of Tehran earthquake rapid earthquake warning network design. *Managing environmental hazards*, Vol. 4, Issue 1, pp. 63–81. DOI: 10.22059/jhsci.2017.63055.
- Pierleoni, P., Concetti, R., Belli, A., Palma, L., Marzorati, S., and Esposito, M. (2023). A Cloud-IoT Architecture for Latency-Aware Localization in Earthquake Early Warning. *Sensors*, Vol. 23, Issue 20. DOI: 10.3390/s23208431.
- Şen, Z. (2011). Supervised fuzzy logic modeling for building earthquake hazard assessment. *Expert Systems With Applications*, Vol. 38, Issue 12, pp. 14564–14573. DOI: 10.1016/j.eswa.2011.05.026.
- Sharma, K., Anand, D., Sabharwal, M., Tiwari, P. K., Cheikhrouhou, O., and Frikha, T. (2021). A Disaster Management Framework Using Internet of Things-Based Interconnected Devices. *Mathematical Problems in Engineering*, Vol. 2021, Issue 1, p. 9916440. DOI: 10.1155/2021/9916440.
- Sultanov K., Kumakov J., Loginov P., and Rikhsieva B. (2020). Strength of underground pipelines under seismic effects. *Magazine of Civil Engineering*, Vol. 93, pp. 97–120. DOI: 10.18720/MCE.93.9.
- Raza, U., Kulkarni, P., and Sooriyabandara, M. (2017). Low Power Wide Area Networks: An Overview. *IEEE Communications Surveys & Tutorials*, Vol. 19, No 2, pp. 855–873. DOI: 10.1109/COMST.2017.2652320.
- Takaoka, H., Hashimoto, H., Ikematsu, S., and Hikida, M. (2006). Prediction Of Landslide-induced Debris Flow Hydrograph: The Atsumari Debris Flow Disaster In Japan. In: Monitoring, Simulation, Prevention and Remediation of Dense and Debris Flows. DOI: 10.2495/DEB060031.
- Thoma, M., Meyer, S., Sperner, K., Meissner, S., and Braun, T. (2012). On IoT-services: Survey, Classification and Enterprise Integration. 2012 IEEE International Conference on Green Computing and Communications, pp. 257–260. DOI 10.1109/GreenCom.2012.47.
- Valizadeh, J., Ghahroudi, A. G., Soltani, S., Akhavan, M., Zaki, A., and Heravi, P. (2024). Mathematical modeling for the closed-loop supply chain with consideration of sustainability risks: a hybrid optimization approach. *Environment, Development and Sustainability*. DOI: 10.1007/s10668-023-04324-4.
- Yanwei, W., Xiaojun, L., Zifa, W., Jianping, Sh., and Enhe, B. (2021). Deep learning for P-wave arrival picking in earthquake early warning. *Earthquake engineering and engineering vibration*, Vol. 20, pp. 391–402. DOI: 10.1007/s11803-021-2027-6.
- Yeh, C.-H., Loh, C.-H., and Tsai, K.-C. (2006). Overview of Taiwan Earthquake Loss Estimation System. *Natural Hazards*, Vol. 37, pp. 23–37. DOI: 10.1007/s11069-005-4654-z.
- Zadeh, L.A. (1965). Fuzzy sets. *Information and Control*, Vol. 8, Issue 3, pp. 338-353.
- Zambrano, A. M., Perez, I., Palau, C., and Esteve, M. (2017). Technologies of Internet of Things applied to an Earthquake Early Warning System. *Future Generation Computer Systems*, Vol. 75, pp. 206–215. DOI: 10.1016/j.future.2016.10.009.
- Zhou, H., Liu, B., and Wang, D. (2012). Design and Research of Urban Intelligent Transportation System Based on the Internet of Things. In: Wang, Y., Zhang, X. (eds) Internet of Things. Communications in Computer and Information Science, Vol. 312. Springer, Berlin, Heidelberg. DOI: 10.1007/978-3-642-32427-7\_82.

## СИСТЕМА РАННЕГО ПРЕДУПРЕЖДЕНИЯ ЗЕМЛЕТРЯСЕНИЙ НА ОСНОВЕ IOT С НЕЧЕТКОЙ ЛОГИКОЙ ДЛЯ УПРАВЛЕНИЯ КОММУНАЛЬНЫМИ СЛУЖБАМИ В ТЕГЕРАНЕ

Махди Ахаван\*, Пурия Рашванд, Мехран Сейед Раззаги

Исламский университет Азад, Филиал в г. Казвин, Казвин, Иран

\*E-mail: info@mahdiakhavan.com

### Аннотация

**Введение.** Сценарии стихийных бедствий предсказать сложно, но подготовиться к ним необходимо. Технология Интернета вещей (IoT), получившая широкое распространение, может сыграть значительную роль в борьбе со стихийными бедствиями. Для стран, особенно подверженных сейсмической активности, внедрение систем раннего предупреждения имеет решающее значение для спасения жизней и минимизации ущерба. Эти системы оповещают людей и власти о наступлении стихийных бедствий. Однако принятию решений после стихийных бедствий по мониторингу основных коммунальных услуг, таких как газ и электричество, в критические периоды уделяется ограниченное внимание. **Методы.** Интеграция IoT с экспертной системой на основе нечеткой логики (Fuzzy system) может улучшить процесс принятия решений после стихийных бедствий, сократить расходы и разрушения в городских районах. Тегеран, город с высоким сейсмическим риском и разветвленной сетью газоснабжения, сталкивается со значительной опасностью повреждения газовых и электрических систем в случае сильных землетрясений. **Результаты.** Исследование показало, что предложенная система IoT-Fuzzy эффективно работает по сравнению с оценкой сейсмической опасности Тегерана, проведенной Японским управлением международного сотрудничества (ЯУМС/ JICA). Система выдает команды на отключение критически важных коммуникаций в течение 10 секунд, основываясь на прогнозе уровня повреждений, помогая снизить вторичный ущерб после землетрясения. Эта система показывает перспективы в улучшении реагирования после стихийных бедствий и защиты городской инфраструктуры.

**Ключевые слова:** управление кризисными ситуациями; интернет вещей; экспертная система на основе нечеткой логики (Fuzzy system); система раннего оповещения; электронные административные услуги (умный город); городское управление.



# STUDY ON LOCAL MICROCLIMATE OF OUTDOOR DOMESTIC SPACES AFTER APPLYING FLOOR AREA RATIO AND MAXIMUM GROUND COVERAGE IN DHAKA CITY

Iftekhhar Rahman, Abhijit Mazumdar\*

Shahjalal University of Science and Technology, Sylhet-3114, Bangladesh

\*Corresponding author's email: abhijit-arc@sust.edu

## Abstract

**Introduction:** Urbanization in Bangladesh is a growing phenomenon. Dhaka is the capital of Bangladesh and has become known as one of the world's megacities. This urban fabric influences the local microclimate of the respective areas. In 2023, the revised building construction rules with Floor Area Ratio and Maximum Ground Coverage introduced outdoor open spaces at ground level within the plots. Thus, various changes in the microclimate are expected, but very little research can be found on these issues. **Aim:** The purpose of this study was to analyze different configurations of outdoor domestic spaces at ground level with a view to the microclimate situation in the context of a planned residential area in Dhaka City. Furthermore, it compares the microclimate of the space configurations. Finally, it is expected to act as a guideline to help the architects and planners. **Method:** Microclimate-based computer simulation and statistical analysis were performed using ENVI-met, SPSS software. Varieties of building blocks (L, N, T, O, H, I, and U) were taken into consideration to see the impact. **Result:** Various building configurations were found to influence the local microclimate. Thus, at the end of this study, potential building configurations essential for a comfortable microclimate were suggested.

**Keywords:** microclimate; urbanization; outdoor domestic space; FAR; MGC.

## Introduction

Urbanization is now a global phenomenon. The world's urban population reached 4.2 billion in 2018 and is expected to rise to 6.7 billion by 2030. Only 30 % of the world's population lived in urban areas in 1950; this proportion increased to 55 % by 2018 (UN, 2018). It is projected that 68 % of the population will live in urban areas by 2050 (UN, 2018). Populations are particularly concentrated worldwide in and around major cities (Yu et al., 2020). Moreover, a report by the (UN, 2018) states that 90 % of urban population growth will occur in Asia and Africa, indicating that the cities in developing countries will face significant challenges in the coming years.

Dhaka serves as the capital of Bangladesh, with an estimated population of 14 million inhabitants (Rahman et al., 2015) with an urbanization rate over 2.5 % (Sharmin et al., 2015). To accommodate this vast urban population, infrastructure in various arenas is expanding, resulting in the proliferation of multi-story buildings in residential sectors. This urban fabric influences local microclimate of these areas, and Dhaka's environmental issues are among the most severe in developing cities. Moreover, microclimate factors are important to the design of outdoor areas to effectively affect user behavior (Ravnikar et al., 2023). Ragheb et al. (2016) assert that integrating climate analysis into the design process must occur at an early stage before the obstruction of spaces by poor choices (Ravnikar et al., 2023). Outdoor spaces facilitate an active

lifestyle, encompassing social and cultural activities; thus, it is a significant challenge and obligation for town planners and scholars to evaluate these places and enhance their accessibility to society (Kumar and Sharma, 2020). Therefore, this study examines how building regulations may affect the local microclimate of the domestic outdoor spaces of buildings. More specifically, it explores how two critical building regulation parameters — Floor Area Ratio (FAR) and Maximum Ground Coverage (MGC) — impact the microclimate in the outdoor spaces of residential buildings in Dhaka City. From these results, urban planners and architects can provide more insightful design solutions to the national level's intervention.

The Dhaka Metropolitan Building Regulations 2023 (MoHPW, 2023) outlines:

$$\text{FAR} = (\text{Total Floor Area}) / (\text{Total Land Area})$$

$$\text{Ground Coverage} = (\text{Built Area} \times 100) / (\text{Total Land Area})$$

## *Background of the study and Statement of the problem*

One of the burning concerns of microclimatic change is the Urban Heat Island Effect. Moreover, it is prevalent in the most major cities and is a well-documented urban phenomenon (Abdollahzadeh and Bioria, 2021). This phenomenon in metropolitan areas are significantly influenced by the unique properties and features of the surfaces present in those regions (Macleane et al., 2021; Gapski et al., 2023). For instance, buildings and paved surfaces in urban

areas absorb solar energy, which is subsequently re-radiated, raising surface temperatures by up to 5.5–10 °C (Akbari, 2009).

Additionally, the urban microclimate is controlled by factors such as street layout, building spacing, building heights, building density, roughness length, urban permeability, surface materials, albedo, vegetation presence, and human heat generation (Oke et al., 1991). Except for the last three factors, the rest are primarily components of urban geometry. Diversity in urban geometry can result in considerable changes in microclimatic conditions (Sharmin et al., 2017). Urban planners, designers, and architects, who are responsible for determining these components, play a crucial role in reducing thermal stress and its impact on health, well-being, and productivity in both indoor and outdoor environments. However, achieving these goals in high-density tropical cities in developing nations poses significant challenges.

Urban residents cannot rely on air conditioning as an efficient remedy due to the limited availability and high cost of electricity. Additionally, air conditioning can exacerbate the issue by increasing anthropogenic heat output, further deteriorating air quality, which is already compromised by vehicle pollutants and nearby brick kilns (Begum et al., 2011). Cooling energy consumption, peak electricity demand, heat-related mortality and morbidity, urban environmental quality, local vulnerability, and comfort are all significantly affected by elevated ambient temperatures (Santamouris, 2020).

Passive ventilation techniques are insufficient to provide unpolluted and comfortable airflow within buildings, as the external environment does not support the demand for indoor environmental quality (IEQ). Dhaka's traditional outdoor spaces, including parks, gardens, squares, and narrow alleys, have historically been hubs of urban activity. The average air temperature, except on wet days, did not exceed 35 °C, making these outdoor spaces habitable. However, in recent decades, due to land scarcity and rising property prices, developers have overtaken these spaces, leading to reduced vegetation and increased air temperatures that directly impact the comfort of urban outdoor areas (Mourshed, 2011).

The spatial distribution of maximum and mean Land Surface Temperature (LST) in Dhaka city indicated increases of 4.62 °C and 6.43 °C, respectively (Imran et al., 2021). Effective urban planning and design could improve the overall microclimate and ensure a healthy living environment both indoors and outdoors. However, reducing city density is a long-term goal that depends on decentralizing the capital, a challenging task in developing nations where the capital serves as the economic hub. Urban planners and designers thus face more challenges and fewer options, necessitating the exploration

of other means to achieve thermal comfort both indoors and outdoors. Dhaka's rapid urbanisation and uncontrolled expansion have led to the urban heat island (UHI) effect and increased air pollution (Azad and Kitada, 1998). In recent decades, the city has seen an unprecedented increase in its urban population. Inadequate planning controls and poor construction laws have resulted in substandard building standards with diminished thermal and ventilation performance. The current construction codes set minimal requirements for space, light, and airflow to maximize the use of existing space (World Bank, 2007). Moreover, Floor Area Ratio significantly impacts the microclimate of urban domestic spaces, influencing the comfort and well-being of residents. High FAR often translates to taller buildings and denser urban forms, creating urban canyons that trap heat and limit air circulation (Jamei et al., 2016; Yu et al., 2020). This tradeoff is particularly pronounced in dense, rapidly urbanizing cities like Dhaka (Sharmin et al., 2015).

To ensure practical interior and outdoor thermal comfort, the Government of Bangladesh (GoB) implemented the Dhaka Imarate Nirman Bidhimala 2008 building regulation acts. Two key regulations, the Floor Area Ratio (FAR) and Maximum Ground Coverage (MGC), are mandatory to obtain permits for architectural building plans. These regulations are responsible for different building shapes and creation of various outdoor spaces for residential buildings in Dhaka City (MoHPW, 2023).

#### *Rationale of the study*

Scopes were increased in the design of buildings by architects after applying the Floor Area Ratio (FAR) and Maximum Ground Coverage (MGC) in Dhaka's building construction rules. Applying FAR and MGC resulted in design variations within the structures designed by architects. Recently, this can be observed in building design by designing different types of outdoor domestic open space configurations at ground levels in buildings, but the question remains: what impact do the outdoor domestic spaces have, considering microclimate (at the local level)? Thus, various changes in microclimate are expected, but very little research can be found on these issues. The setting of each city is distinct; thus, conducting field studies in many cities is essential to enhance our current understanding of creating healthy urban environments (Sharmin et al., 2019). Therefore, this research focuses on multiple shapes of outdoor domestic spaces created at the ground level of buildings after applying FAR and MGC based building construction rules and investigates the various outcomes of the local microclimate effect due to different building forms through microclimate-based computer simulation. It is expected to act as a guideline to help the architects and

planners. Additionally, when designing buildings, after applying the **FAR** and **MGC** based building construction rules of Dhaka City for a desired microclimate-based outcome, it is expected that the readers, architects, microclimate environment researchers, environmentalists, and building regulation authorities would be very interested and would like to go through this study.

#### *Objectives of the study*

##### *General Objective*

The objective of the study is to investigate whether microclimate variations can be observed at ground-level domestic open spaces created after applying **FAR** and **MGC** in residential areas considering adjacent building blocks.

##### *Specific Objectives*

I. To investigate the interrelationships of considered parameters MRT (Mean Radiant Temperature), DBT (Dry Bulb Temperature), RH (Relative Humidity) and WS (Wind Speed) due to various domestic space configurations within plot areas.

II. To find out possible outdoor spaces within plots after applying FAR & MGC in residential areas in Dhaka city.

III. To investigate the impact of outer façade of a built structure orientation on local microclimate of domestic spaces within plot areas.

IV. To simulate the microclimate situation of outdoor domestic spaces through ENVI-met (software) for analysis.

V. Statistical analysis of the microclimate data from simulation to find out which configuration/s are best fit considering microclimate conditions in residential urban blocks of domestic outdoor spaces after applying FAR and MGC of building construction rules practiced in Dhaka city.

#### **Methods**

First of all, relevant published materials and previously done research on street morphology, urban canyons, urban microclimate, outdoor thermal comfort, and FAR regulations was thoroughly analyzed. Initially, eight planned residential neighborhoods in Dhaka, including Gulshan, Dhanmondi, Banani, Uttara, and Baridhara, was observed visually. The "Uttara residential region" was chosen for reconnaissance based on the availability of residential structures in such areas. As there is no sector in those residential neighborhoods where all buildings have been created in accordance with FAR regulation, a reconnaissance study was done to identify two sectors where at least **fifty per cent** of structures have been constructed in accordance with FAR & MGC rules, 2008. In the reconnaissance study, all orthogonal routes in the residential area of Uttara were thoroughly explored.

The research was conducted through microclimate simulation software **ENVI-met** version 3.1, beta 5, an established and authenticated software vastly

used for urban outdoor microclimate analysis. A planned residential block (sector-14, Uttara) was considered in the research. As varieties of building blocks are possible in an urban block, selected varieties of building block shapes were taken into consideration to see the impact on the urban microclimate environment and closely observed the changes achieved. Besides, the simulation field survey was conducted in planned residential area/s to compare and justify the study. Various points were selected within the domestic spaces selected in the research, in a view to having equal distances for having true scenario as much as possible for collecting the measurements of microclimatic data, such as **DBT** (Dry Bulb Temperature), **MRT** (Mean Radiant Temperature), **RH** (Relative Humidity) and **WS** (Wind Speed) and analysis was done through statistical software **SPSS** version 23.

#### *Research quality consideration*

Research quality considerations were as follows:

##### *- Independent variables:*

- Orientation
- Domestic shape configuration due to Form layout/building shape

##### *- Dependent variables: [Microclimate parameters]*

- Temperature
  - MRT (Mean radiant temperature) (K)
  - DBT (Dry bulb temperature) (K)
  - DBT diff. (K)
  - DBT change (K/h)

- Wind speed
  - Wind speed (m/s)
  - Wind speed change (%)

##### *- Unit of assignment*

- Domestic outdoor spaces
- Outdoor activity areas

##### *- Control group [Groups to which no treatment is applied]*

- Surrounding surface materials
- Different plot sizes
- Vegetation
- Other FARs and MGCs
- Impact of vehicular movements

##### *- Focus on Causality*

- The focus on causality was "the effect of outdoor domestic space configuration on local microclimate considering "on-ground" and "elevated" structures".

#### *Sampling for the simulation*

Different possible building shapes were considered to have outdoor domestic spaces after applying FAR and MGC. The simulation was done on a hot summer day (March to June). 33 decimal plots in the residential area were considered during the simulation. Simulation in the evening time is

considered to be 5 pm and 6 pm (considering outdoor activities). Different possible building shapes were considered, such as 'L', 'N', 'T', 'O', 'H', 'I', and 'U' shaped blocks at different positions having outdoor domestic spaces (Fig. 1), and data were collected at different points of the domestic spaces (Fig. 2). In this case, the "on-ground" and "elevated" building structures were taken into consideration for separate the simulation. Residential buildings classified as "on-ground" are those whose ground floors are designed for family living. In contrast, there are no residential arrangements, and the ground floors of the "elevated" residential building are left to be used for parking or security facilities only.

**Results**

Simulation result outputs are shown on Figs. 3–4.

*Data analyses for "On-ground" structures*

In the above table (Table 1), data that were statistically significant are marked "yellow", and the shape of the corresponding building patterns are shown, where it can be seen that considering various building shapes impacts microclimate data in various ways. Having open domestic spaces at different locations thus impacts significantly considering different times also. As for a tropical climate, a lower temperature and higher wind speed are desirable for better microclimatic comfort. Keeping these two factors in mind, from this data set we can state that the inverted 'T' shape building is more suitable.

*Data analyses for "Elevated" Structures*

Similarly, in the above table (Table 2), data which were statistically significant are marked "yellow", and

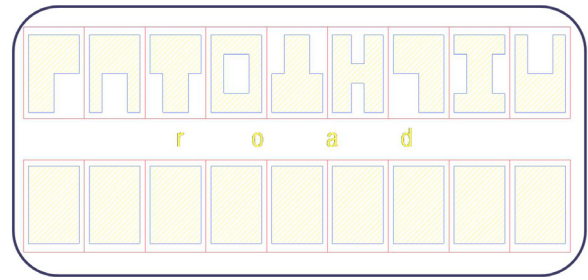
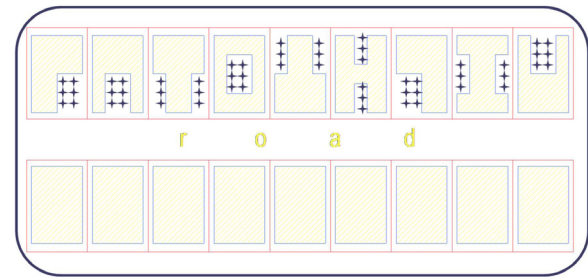

Fig. 1. Considered different shapes of buildings within the plots



+ Data collection points

Fig. 2. Considered points of data extraction considering domestic spaces of different building shapes

the shape of the corresponding building patterns are shown where it can be seen that considering various building shapes impacts microclimate data in various ways. Having open domestic spaces at different locations thus impacts significantly considering different times also. As was previously mentioned,

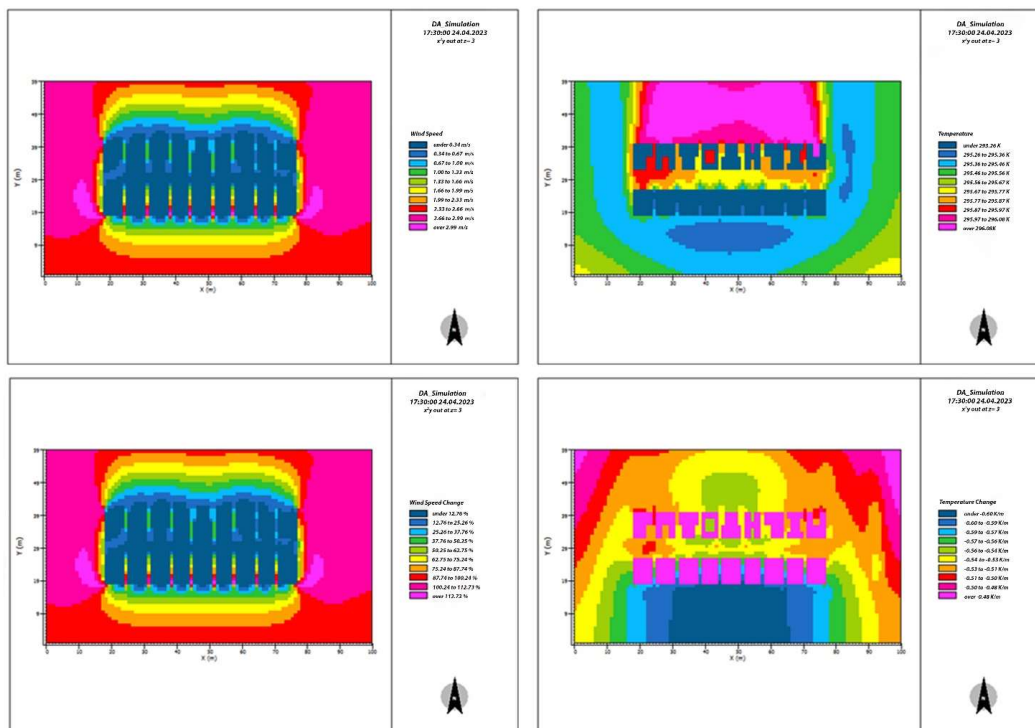

Fig. 3. Simulation outputs considering "On-ground" structures

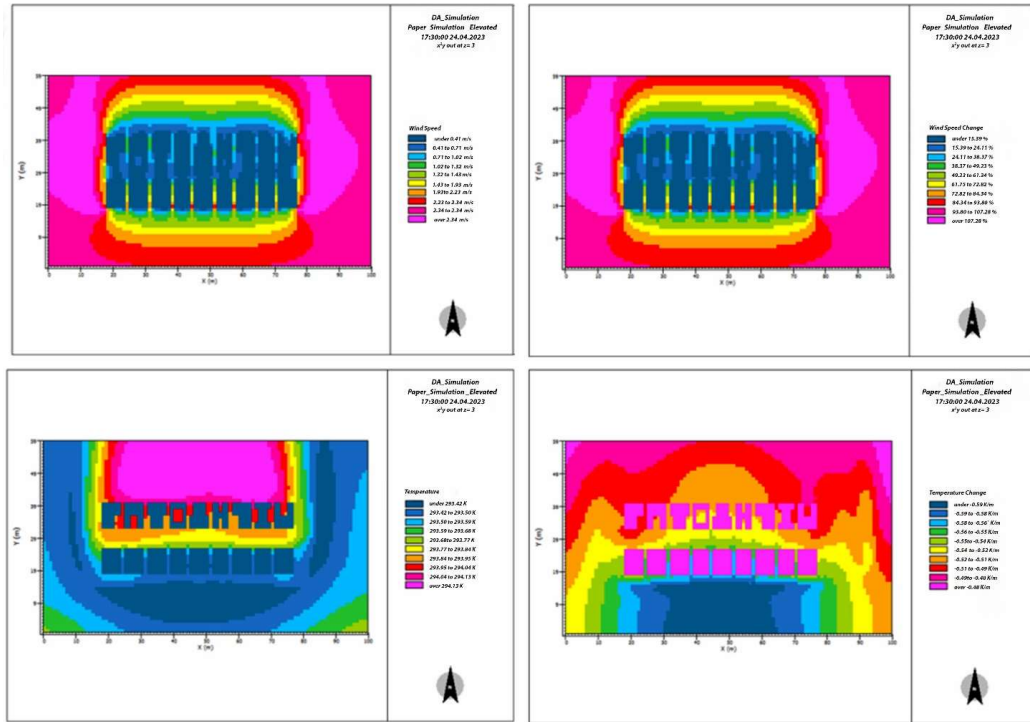

Fig. 4. Simulation outputs considering "Elevated" structures

Table 1. Micro-climate data considering "On-ground" structures at 5 pm and 6 pm

5 pm						On-ground structures	6 pm					
Wind speed (m/s)	Wind speed change (%)	MRT (K)	DBT (K)	DBT temp. diff. (K)	DBT temp. change (K/h)	Building shapes	Wind speed (m/s)	Wind speed change (%)	MRT (K)	DBT (K)	DBT temp. diff. (K)	DBT temp. change (K/h)
0.34–0.67	12.84–25.26	Under 293.57	296.26–296.36	0.29–0.39	2–3.7		0.34–0.67	12.73–25.23	287.69–288.17	295.54–295.66	0.26–0.37	–0.69––0.66
Under 0.34	Under 12.84	Under 293.57	296.31–296.42	0.34–0.44	1.16–2.85		Under 0.34	Under 12.73	287.93–288.42	295.54–295.66	0.26–0.37	–0.69––0.66
0.34–0.67	12.84–25.26	293.57–297.10	296.16–296.26	0.18–0.29	0.31–2.00		0.34–0.67	12.73–25.23	287.45–287.93	295.32–295.43	0.04–0.15	–0.71––0.68
5 pm						On-ground structures	6 pm					
Under 0.34	Under 12.84	Under 293.57	296.36–296.47	0.39–0.49	0.31–2.00		Under 0.34	Under 12.73	288.17–288.66	295.54–295.66	0.26–0.37	–0.66––0.62
0.67–1.00	25.26–37.69	Under 293.57	296.16–296.26	0.18–0.29	2.00–3.70		0.67–1.00	25.23–37.73	287.20–287.69	295.38–295.49	0.095–0.21	–0.71––0.68
Under 0.34	Under 12.84	293.57	296.26–296.36	0.29–0.39	1.38–0.31		Under 0.34	Under 12.73	288.17–288.66	295.54–295.66	0.26–0.37	–0.69––0.66
0.34	12.84–25.26	293.57–297.10	296.16–296.26	0.18–0.29	0.31–2.00		0.34	12.73–25.23	287.69–288.17	295.32–295.43	0.04–0.15	–0.69––0.66
Under 0.34	12.84–25.26	293.57–297.10	296.21–296.31	0.24–0.34	2.00–3.70		Under 0.34	Under 12.73	288.17–288.66	295.43–295.54	0.15–0.26	–0.68––0.64
Under 0.34	Under 12.84	Under 293.57	296.36–296.47	0.39–0.49	2.85–4.55		Under 0.34	Under 12.73	287.45–287.93	295.66–295.77	0.37–0.49	–0.66––0.62

Table 2. Micro-climate data considering ‘Elevated’ structures at 5 pm and 6 pm

5 pm						Elevated structures	6 pm					
Wind speed (m/s)	Wind speed change (%)	MRT (K)	DBT (K)	DBT temp. diff. (K)	DBT temp. change (K/h)	Building shapes	Wind speed (m/s)	Wind speed change (%)	MRT (K)	DBT (K)	DBT temp. diff. (K)	DBT temp. change (K/h)
0.72–1.02	38.59–50.11	Under 293.57	296.24–296.33	0.22–0.31	0.29–1.33		0.56–0.87	15.4–26.86	288.14–288.62	295.56–295.66	0.22–0.32	-0.78–-0.30
5 pm						Elevated structures	6pm					
0.41–0.72	15.55–27.07	Under 293.57	296.33–296.42	0.31–0.41	0.29–1.33		0.41–0.71	15.4–26.86	287.18–287.66	295.56–295.66	0.22–0.32	-0.78–-0.30
0.72–1.02	15.55–27.07	293.57–297.11	296.33–296.42	0.31–0.41	Over 1.33		0.41–0.71	21.13–32.59	287.42–287.90	295.56–295.66	0.22–0.32	-1.25–-0.78
Under 0.41	Under 15.55	293.57–297.11	296.38–296.47	0.36–0.46	0.29–1.33		Under 0.41	Under 15.40	287.66–288.14	295.66–295.76	0.32–0.42	Over -0.3
0.71–1.02	27.07–38.59	293.57–297.11	296.38–296.47	0.36–0.46	Over 1.33		0.56–0.87	21.13–32.59	286.94–287.42	295.56–295.66	0.27–0.37	-1.72–-2.2
0.41–0.72	15.55–27.07	293.57–297.11	296.33–296.42	0.31–0.41	0.29–1.33		0.41–0.71	15.4–26.86	287.66–288.14	295.61–295.71	0.27–0.37	-1.25–-0.30
0.72–1.02	38.59–50.11	293.57–297.11	296.29–296.38	0.27–0.36	0.29–1.33		0.41–0.71	15.4–26.86	286.94–287.42	295.56–295.66	0.22–0.32	-0.78–-0.30
0.41–0.72	15.55–27.07	293.57–297.11	296.33–296.42	0.31–0.41	Over 1.33		0.56–0.87	21.13–32.59	287.66–288.14	295.61–295.76	0.27–0.42	-1.72–-0.78
0.41–0.72	27.07–38.59	Under 293.57	296.33–296.38	0.31–0.36	0.29–1.33		0.56–0.87	21.13–32.59	286.94–287.42	295.66–295.76	0.32–0.42	-0.78–-0.30

for better microclimatic comfort, lower temperatures and higher wind speeds are preferred. Considering these two factors, we can state that the two inverted ‘L’ shapes facing each other are the most suitable placement for the elevated structures.

**Discussion**

After analyzing the corresponding data of the simulation outputs, desirable building shapes considering favourable microclimate conditions for ‘on-ground’ and ‘elevated’ structures can be divided in the following ways (Fig. 5 and Fig. 6).

*Limitations of the study & Further scope of work*

Although the study yielded useful insights, it also revealed many shortcomings that indicate possible areas for further research. Initially, the presence of *vegetations* was not taken into account, which could have a substantial influence on the outcomes, particularly in investigations of urban microclimates. The simulation was carried out during a *24-hour period*, which restricted the study’s temporal range and may have disregarded any *seasonal fluctuations*. Additionally, the study solely simulated wind blowing towards the *south*, disregarding the impacts of breezes coming from *other directions (i. e. north, east and west)*, which could produce contrasting outcomes in an actual situation.

Furthermore, the research failed to consider the diversity in *road widths* that could affect

environmental factors such as heat retention and wind flow, and it only accounted for a single road width. It also presumed that all building materials were the same. Additionally, irregular building forms, which may have a significant impact on how airflow and temperature are distributed in cities, were not taken into account and the study only looked at 33 decimal plots. Finally, the study disregarded the influence of traffic movements, so neglecting a crucial factor that could potentially effect air quality and noise levels in urban settings.

These constraints indicate that future research should encompass a wider array of factors, such as diverse construction materials, multiple wind orientations, varying road widths, different plot dimensions, irregular building shapes, and the influence of vegetation and vehicular movements. This will yield a more comprehensive comprehension of the topic.

**Conclusion**

The study aimed to examine if there are observable microclimate changes in ground-level domestic open spaces that are generated after implementing FAR (Floor Area Ratio) and MGC (Maximum Ground Coverage) in residential areas, taking into account the nearby building blocks. From the study above, it can clearly be stated that there is a significant relationship in terms of

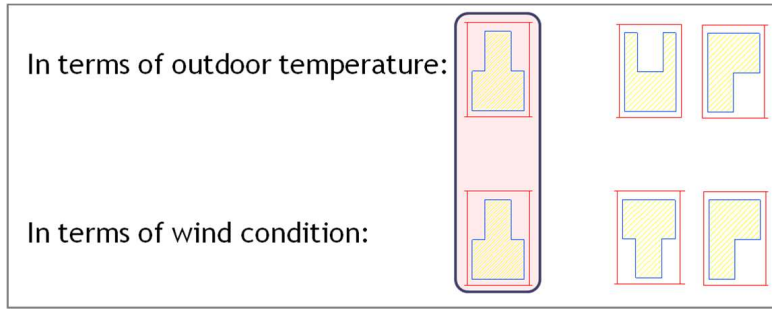

Fig. 5. Graphical presentation of favorable results considering "On-ground" structures [In the left, shaded part denotes most suitable building shape regarding temperature and wind condition]

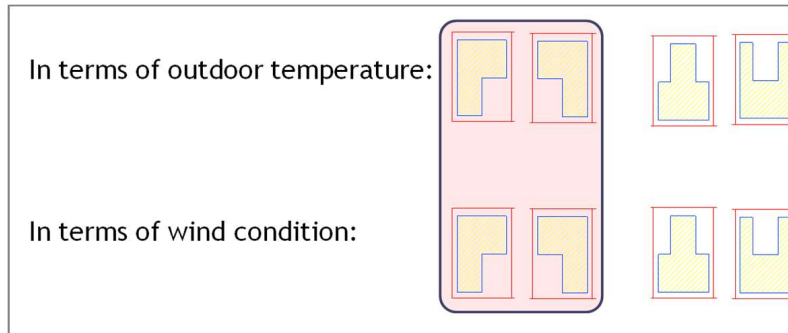

Fig. 6. Graphical presentation of a favorable result considering "Elevated" structures [In the left, shaded part denotes most suitable building shape regarding temperature and wind condition]

building shape and outdoor domestic spaces used, considering the local microclimate. In the case of a tropical climate, achieving a lower temperature and higher wind speed is preferable in order to enhance microclimatic comfort. By considering these two factors, it is evident from the study that the inverted 'T' shape building is more appropriate for on-ground structures, while the two inverted 'L' shapes that face each other are the most suitable positioning for elevated structures. Apart from the limitations of the study and considering the future aspects of further

work in this regard, it is necessary to examine such relationships, which will eventually help in future domestic space design for residential buildings to improve the outdoor environment and thus influence urban microclimate.

#### Funding

The article was prepared as part of the work on the research project by the Shahjalal University of Science and Technology Research Center, Sylhet-3114, Bangladesh [grant numbers AS/2022/1/03].

## References

- Abdollahzadeh, N. and Biloría, N. (2021). Outdoor thermal comfort: Analyzing the impact of urban configurations on the thermal performance of street canyons in the humid subtropical climate of Sydney. *Frontiers of Architectural Research*, Vol. 10, Issue 2, pp. 394–409. DOI: 10.1016/j.foar.2020.11.006.
- Akbari, H. (2009). Cooling our Communities. A Guidebook on Tree Planting and Light-Colored Surfacing'. *Lawrence Berkeley National Laboratory* [Preprint]. Available at: <https://escholarship.org/uc/item/98z8p10x> (Accessed: January 1, 2024).
- Azad, A. K. and Kitada, T. (1998). Characteristics of the air pollution in the city of Dhaka, Bangladesh in winter. *Atmospheric Environment*, Vol. 32, Issue 11, pp. 1991–2005. DOI: 10.1016/S1352-2310(97)00508-6.
- Begum, B. A., Biswas, S. K., and Hopke, P.K. (2011). Key issues in controlling air pollutants in Dhaka, Bangladesh. *Atmospheric Environment*, Vol. 45, Issue 40, pp. 7705–7713. DOI: 10.1016/j.atmosenv.2010.10.022.
- Gapski, N. H., Marinoski, D. L., Melo, A. P. and Guths, S. (2023). Impact of urban surfaces' solar reflectance on air temperature and radiation flux. *Sustainable Cities and Society*, Vol. 96, p. 104645. DOI: 10.1016/j.scs.2023.104645.
- Imran, H. M., Hossain, A., Islam, A. K. M. S., Rahman, A., Bhuiyan, A. E., Paul, S., and Alam, A. (2021). Impact of Land Cover Changes on Land Surface Temperature and Human Thermal Comfort in Dhaka City of Bangladesh. *Earth Systems and Environment*, Vol. 5, Issue 3, pp. 667–693. DOI: 10.1007/s41748-021-00243-4.
- Jamei, E., Rajagopalan P., Seyedmahmoudian, M., and Jamei, Ya. (2016). Review on the impact of urban geometry and pedestrian level greening on outdoor thermal comfort. *Renewable and Sustainable Energy Reviews*, Vol. 54, pp. 1002–1017. DOI: 10.1016/j.rser.2015.10.104.
- Kumar, P. and Sharma, A. (2020). Study on importance, procedure, and scope of outdoor thermal comfort – A review. *Sustainable Cities and Society*, Vol. 61, p. 102297. DOI: 10.1016/j.scs.2020.102297.
- Maclean, I. M. D., Duffy, J. P., Haesen, S., Govaert, S., De Frenne, P., Vanneste, Th., Lenoir, J., Lembrechts, J. J., Rhodes, M. W., and Meerbeek, K. V. (2021). On the measurement of microclimate. *Methods in Ecology and Evolution*, Vol. 12, Issue 8, pp. 1397–1410. DOI: 10.1111/2041-210X.13627.
- MoHPW (2023) *Dhaka Metropolitan Building Regulations 2023*. Bangladesh: Ministry of Housing and Public Works. Available at: <https://mohpw.gov.bd/site/notices/b5d3dd6d-d569-4a4d-aeb2-1d945808c521/>.
- Mourshed, M. (2011). The impact of the projected changes in temperature on heating and cooling requirements in buildings in Dhaka, Bangladesh. *Applied Energy*, Vol. 88, Issue 11, pp. 3737–3746. DOI: 10.1016/j.apenergy.2011.05.024.
- Oke, T. R., Johnson, G. T., Steyn, D. G., and Watson, I. D. (1991). Simulation of surface urban heat islands under “ideal” conditions at night part 2: Diagnosis of causation. *Boundary-Layer Meteorology*, Vol. 56, Issue 4, pp. 339–358. DOI: 10.1007/BF00119211.
- Ragheb, A. A., El-Darwish, I.I., and Ahmed, S. (2016). Microclimate and human comfort considerations in planning a historic urban quarter. *International Journal of Sustainable Built Environment*, Vol. 5, Issue 1, pp. 156–167. DOI: 10.1016/j.ijbsbe.2016.03.003.
- Rahman, Md. Z., Siddiqua, S., and Kamal, A. S. M. M. (2015). Liquefaction hazard mapping by liquefaction potential index for Dhaka City, Bangladesh. *Engineering Geology*, Vol. 188, pp. 137–147. DOI: 10.1016/j.enggeo.2015.01.012.
- Ravnikar, Ž., Bahillo, A., and Goličnik Marušić, B. (2023). A Protocol for Microclimate-Related Street Assessment and the Potential of Detailed Environmental Data for Better Consideration of Microclimatology in Urban Planning. *Sustainability*, Vol. 15, Issue 10, p. 8236. DOI: 10.3390/su15108236.
- Santamouris, M. (2020). Recent progress on urban overheating and heat island research. Integrated assessment of the energy, environmental, vulnerability and health impact. Synergies with the global climate change. *Energy and Buildings*, Vol. 207, p. 109482. DOI: 10.1016/j.enbuild.2019.109482.
- Sharmin, T., Steemers, K., and Humphreys, M. (2019). Outdoor thermal comfort and summer PET range: A field study in tropical city Dhaka. *Energy and Buildings*, Vol. 198, pp. 149–159. DOI: 10.1016/j.enbuild.2019.05.064.
- Sharmin, T., Steemers, K., and Matzarakis, A. (2015). Analysis of microclimatic diversity and outdoor thermal comfort perceptions in the tropical megacity Dhaka, Bangladesh. *Building and Environment*, Vol. 94, pp. 734–750. DOI: 10.1016/j.buildenv.2015.10.007.
- Sharmin, T., Steemers, K., and Matzarakis, A. (2017). Microclimatic modelling in assessing the impact of urban geometry on urban thermal environment. *Sustainable Cities and Society*, Vol. 34, pp. 293–308. DOI: 10.1016/j.scs.2017.07.006.
- UN (2018) *World urbanization prospects : the 2018 revision*. ST/ESA/SER.A/421. New York, p. 323. Available at: <https://digitallibrary.un.org/record/639679?ln=enandv%3Dpdf&v=pdf> (Accessed: 5 December, 2023).



World Bank (2007) *Dhaka : Improving living conditions for the urban poor*. Working Paper (Numbered Series) 27. Washington, D.C: World Bank Group. Available at: <http://documents.worldbank.org/curated/en/938981468013830990/Dhaka-Improving-living-conditions-for-the-urban-poor>.

Yu, Z., Chen, S., and Wong, N. H. (2020). Temporal variation in the impact of urban morphology on outdoor air temperature in the tropics: A campus case study. *Building and Environment*, Vol. 181, p. 107132. DOI: 10.1016/j.buildenv.2020.107132.

# ИССЛЕДОВАНИЕ МЕСТНОГО МИКРОКЛИМАТА НАРУЖНЫХ БЫТОВЫХ ПОМЕЩЕНИЙ ПОСЛЕ ПРИМЕНЕНИЯ КОЭФФИЦИЕНТА ПОЛЕЗНОЙ ПЛОЩАДИ И МАКСИМАЛЬНОГО ПОКРЫТИЯ ЗЕМЕЛЬНЫХ УЧАСТКОВ В ГОРОДЕ ДАККА

Ифтехар Рахман, Абхиджит Мазумдар\*

Шахджалальский университет науки и технологий (SUST), г. Силхет, 3114, Бангладеш

\*E-mail: abhijit-arc@sust.edu

## Аннотация

**Введение.** Процесс урбанизации в Бангладеш приобретает все больший размах. Дакка — столица Бангладеш, которая стала известна как один из мегаполисов мира. Городская структура влияет на микроклимат прилегающих районов. В 2023 году в соответствии с измененными правилами строительства зданий с учетом коэффициента полезной площади и максимального покрытия территории введены правила строительства открытых пространств на уровне первого этажа в пределах земельных участков. В связи с этим ожидаются различные изменения микроклимата, однако исследований по этим вопросам очень мало. **Цель исследования:** анализ различных конфигураций открытых пространств жилых домов на уровне первого этажа с точки зрения микроклимата на примере проектируемого жилого района в городе Дакка. Помимо этого, в исследовании проводится сравнение микроклимата при различных конфигурациях пространств. Мы предполагаем, что этот документ станет хорошим подспорьем для архитекторов и проектировщиков. **Методы.** Компьютерное моделирование микроклимата и статистический анализ проводились с использованием программ ENVI-met, SPSS. Для определения воздействия были приняты во внимание различные варианты строительных блоков («L», «N», «T», «O», «H», «I» и «U»). **Результаты.** Было установлено, что различные конфигурации конструкций зданий оказывают воздействие на местный микроклимат. Поэтому по результатам проведенного исследования были предложены потенциальные конструкции зданий, обеспечивающие комфортный микроклимат.

**Ключевые слова:** микроклимат; урбанизация; открытое пространство жилого дома; коэффициент полезной площади (FAR); коэффициент максимального покрытия земельных участков (MGC).

## THERMOPHYSICAL PROCESSES IN HARDENING CONCRETE AS A FACTOR FOR QUALITY ASSURANCE OF ERECTED REINFORCED CONCRETE STRUCTURES OF TRANSPORT FACILITIES

Sergey Fedosov<sup>1</sup>, Ivan Pulyaev<sup>2\*</sup>, Olga Aleksandrova<sup>1</sup>, Nadezhda Cherednichenko<sup>3</sup>, Evgeniya Derbasova<sup>2</sup>, Yuliya Lezhnina<sup>4</sup>

<sup>1</sup>Moscow State University of Civil Engineering (National Research University), Moscow, Russia

<sup>2</sup>Moscow Polytechnic University, Moscow, Russia

<sup>3</sup>Russian University of Transport (MIIT), Moscow, Russia

<sup>4</sup>MIREA – Russian Technological University (RTU MIREA), Moscow, Russia

\*Corresponding author's email: ivanes50@mail.ru

### Abstract

**Introduction.** This paper presents the main issues of maintenance of structural properties of concrete depending on the effect of temperature factor and heat and mass transfer processes in contact with the environment during the construction of transport facilities erected from monolithic reinforced concrete under different initial and limiting conditions. **Purpose of study:** quality assurance of preliminary design studies of reinforced concrete structures, including full-scale modeling of the considered thermophysical processes in hardening concrete, including use of modern calculation and analytical software packages. **Methods:** application of a special software package for calculation of temperature changes and strength of hardening concrete, estimation of temperature factor impact on the following concrete properties: frost resistance, water resistance, strength and crack resistance. **Results:** it is shown that recording of the thermal stressed state of hardening concrete allows to ensure required operational properties of structures: quality, reliability, durability, including prevention of appearance of temperature and shrinkage cracks, — one of the most common defects in transportation construction, that reduce quality of the erected surface. The studies described in this paper have been widely tested at Russian transportation facilities in Moscow, St. Petersburg, Kuban, Crimea and other regions, the obtained results have resonated with the transport industry. The paper will be interesting and useful for persons involved in the processes of quality assurance of defect-free concreting of multi-mass concrete structures of transportation facilities, as well as for engineers and technicians engaged in the real sector of construction.

**Keywords:** concrete; thermal stresses; thermophysical processes; crack resistance; modulus of structure surface.

### Introduction

The radical changes in the economic conditions of the operation and development of the country's production sector that took place in Russia at the end of the 20<sup>th</sup> century led to the priority use of road transport in our country. This in turn required the construction of appropriate motorways, flyovers, bridge crossings, tunnels, numerous road junctions and other types of transport facilities throughout its territory (Ginzburg, 2014; Kosmin et al., 2014; Vasiliev and Veitsman, 2015; Solovyanchik et al., 2006; Balyuchik and Cherny, 2010).

The required scope of construction works since the end of the 90 s has been met mainly due to the large-scale use of monolithic reinforced concrete in transport construction, which successfully provides architectural expressiveness and diversity of design solutions used in practice.

Wide application of monolithic reinforced concrete was mainly facilitated by supply of highly efficient

and highly productive equipment to the transport market for preparation, transportation and delivery of concrete mixtures to the place of paving, as well as wide use of new modern additives of different effect. (Sokolov, 2002; Passek et al., 2002; Komandrovsky, 2003; Velichko and Cherny, 2013; Solovyanchik and Shifrin, 2000).

However, the initial experience of large transportation facilities construction, including reconstruction of the Moscow Ring Road, showed that in the process of construction of structural elements of different masses, various defects began to appear on their surface in the form of cracks, spalls, sinks, which led to intensive and consistent destruction of the erected structures at the initial stage of their active operation and loading (Pryakhin, 2009; Sokolov, 2002; Solovyanchik et al., 2002; Solovyanchik et al., 2003; Kosmin and Mozalev, 2014).

It turned out that, during the use of concrete of high classes in combination with the intensive pace

of concrete works and the need to erect structures in massive blocks, a fundamentally new integrated approach is required to ensure the necessary quality, reliability and durability of transport structures, related to the effects of a whole series of thermophysical processes both on the hardening concrete and on the erection of individual structural elements and the structure as a whole (Pryakhin, 2009; Tarasov et al., 2007; Velichko, 1987; Evlanov, 2019).

However, the current rules and regulations with its requirements regarding thermal processes occurring in hardening concrete reflects only restrictions in permissible heating temperature of the concrete mixture and on critical temperature differences between the concrete and the environment during formwork removal from concrete structures (Concu and Trulli, 2018; Zvorykin et al., 2017). At the same time, the latter limitation is formulated only for structures with a surface modulus of  $2 \text{ m}^{-1}$  or more.

Physical picture of the thermal processes development in the system ‘hardening concrete plate — formwork’, can be presented in the form of a graph in Fig. 1.

The curves illustrate development of temperature fields in the model plate and formwork. It is assumed that inside the plate (in its entire area) there is a distributed source of heat —  $q_{VT}(\tau)$ , due to the effects of hydration of cement components. From the side surface the heat flux —  $q_f(\tau)$  is discharged. This flux is transferred by heat conduction through the formwork layer of size —  $\delta_f$  and then from the outside of the formwork is removed to the environment by the mechanism of convective heat transfer.

Based on the above stated physical and mathematical picture of the processes occurring in a solidifying monolithic reinforced concrete slab, we synthesize a mathematical model of the processes of interconnected heat and mass transfer in a plate of limited dimensions, complicated by the thermal

effect of hydration reactions of binder components (Fedosov, 2010; Fedosov et al., 2024):

$$\frac{\partial t}{\partial \tau} = \nabla(a\nabla t) + \varepsilon \frac{r^*}{c} \frac{\partial u}{\partial \tau}; \quad (1)$$

$$\frac{\partial u}{\partial \tau} = \nabla(k\nabla u) + \nabla(k\delta_T\nabla t). \quad (2)$$

Equation (1) is a differential equation of non-stationary heat conduction and reflects the fact that in a given point of space of the hardening concrete mass, the temperature change —  $t(x,y,z,\tau)$  — occurs both in time  $t$  and in coordinates —  $x,y,z$ .

At the same time, both temperature (in particular) and temperature field (in general) are impacted by material properties: density ( $\rho_0$ ), heat capacity ( $c^*$ ), thermal conductivity ( $\lambda$ ), which also generally depend on temperature and humidity and, therefore, vary both in time and in coordinates

Equation (2) is a differential equation of unsteady moisture conduction; it shows that moisture transport in a given point of space is determined by mass conduction (diffusion in solid  $k$ ), as well as by such phenomena as thermodiffusion  $\delta_T$  and pressure transfer  $\delta_p$ .

As a rule, the initial conditions for nonstationary heat and mass transfer problems are the values of potentials at the moment of time taken as the origin:

$$t(x,y,z,\tau)|_{\tau=0}; u(x,y,z,\tau)|_{\tau=0}; \rho(x,y,z,\tau)|_{\tau=0}, \quad (3)$$

The limiting conditions, in general, should be recorded in the form of conditions of the III kind, they define the conditions of heat and mass transfer at the plate boundaries:

$$\alpha [t_c(\tau) - t(R,\tau)] = \lambda \nabla t(R,\tau) + q_m(\tau) r^*; \quad (4)$$

$$q_m(\tau) = \beta [u_{nc}(\tau) - u_c(\tau)] \rho_g = -k [\nabla u(R,\tau) + \delta_T \nabla t(R,\tau)], \quad (5)$$

where  $q_m(\tau)$  is the moisture flux from a unit of material surface  $\text{kg/m}^2\text{s}$ .

In thermal treatment processes of the greater part of construction materials, the temperature does not reach the value of  $100 \text{ }^\circ\text{C}$  (otherwise, moisture boiling occurs in the material, leading to a change in the B/C ratio and the subsequent procedure of structure formation). Taking this into consideration, the system of equations (1), (2) may be transformed to a simpler form:

$$\frac{\partial t}{\partial \tau} = \nabla(a\nabla t) + q_{VT}; \quad (6)$$

$$\frac{\partial u}{\partial \tau} = \nabla(k\nabla u) + \nabla(k\delta_T\nabla t). \quad (7)$$

At the same time, we pay attention to the fact that in absence of internal moisture evaporation ( $\Sigma = 0$ ), the last element of the right-hand side in equation (1) turns to zero. But, at the same time, there are processes of hydration of binder components

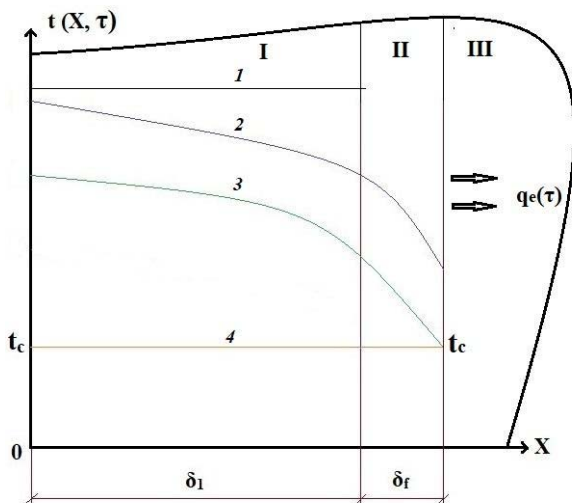

Fig. 1. Illustration of the dynamics of heat exchange processes

in the concrete mixture. They are accompanied by the release of reaction heat. This phenomenon is characterized by a new element in the right part of equation (6) — a volumetric source of heat due to chemical transformations.

In accordance with the stated physical concepts of the process, let us consider the mathematical model of heat transfer in the system under study in one-dimensional formulation.

In this case, it is logical to assume symmetry of the temperature field in the model plate. In this case, the boundary value problem of heat conduction for the plate is written as follows:

$$\frac{\partial T_1(\bar{x}, F_{O1})}{\partial F_{O1}} = \frac{\partial^2 T_1(\bar{x}, F_{O1})}{\partial \bar{x}^2} + Po(\bar{x}, F_{O1});$$

$$F_{O1} > 0; 0 \leq \bar{x} \leq 1; \quad (8)$$

$$T_1(\bar{x}, F_{O1})|_{F_{O1}} = T_{1,0}(\bar{x}); \quad (9)$$

$$\frac{\partial T_1(\bar{x}, F_{O1})}{\partial \bar{x}}|_{\bar{x}=0} = 0; \quad (10)$$

$$\frac{\partial T_1(\bar{x}, F_{O1})}{\partial \bar{x}}|_{\bar{x}=1} = -Ki_l(F_{O1}). \quad (11)$$

The equation (9) shows that, in general, the initial temperature distribution is non-uniform along the coordinate. Equation (10) represents a symmetry condition. Equation (11) shows that there is a heat flux at the boundary of the concrete slab with the formwork, the magnitude of which is generally a function of time variable.

The heat conduction requirement for the formwork may be represented as follows:

$$\frac{\partial T_2(\bar{x}, F_{O2})}{\partial F_{O2}} = \frac{\partial^2 T_2(\bar{x}, F_{O2})}{\partial \bar{x}^2}; F_{O2} > 0; 0 \leq \bar{x} \leq 1; \quad (12)$$

$$T_2(\bar{x}, F_{O2})|_{F_{O2}} = T_{2,0}(\bar{x}); \quad (13)$$

$$\frac{\partial T_2(\bar{x}, F_{O2})}{\partial \bar{x}}|_{\bar{x}=0} = -Ki_l(F_{O2}); \quad (14)$$

$$\frac{\partial T_2(\bar{x}, F_{O2})}{\partial \bar{x}}|_{\bar{x}=1} = -Ki_r(F_{O2}). \quad (15)$$

Together with the condition of temperature equality, they constitute the limiting condition of the IV kind. Equation (15) characterizes the condition of heat exchange of the external surface of the formwork with the environment.

For dimensionless values and similarity criteria we shall use the following formula:

$$T_1(\bar{x}, F_{O1}) = \frac{t_1(x, \tau) - t_{1,0}}{t_e}; \quad (16)$$

$$T_2(\bar{x}, F_{O2}) = \frac{t_2(x, \tau) - t_{2,0}}{t_e}; \quad (17)$$

$$\bar{x} = \frac{x}{\delta}, \quad \delta = [\delta_1, \delta_f]; \quad (18)$$

$$F_{O1} = \frac{a_1 \tau}{\delta_1^2}; F_{O2} = \frac{a_2 \tau}{\delta_f^2}. \quad (19)$$

Pomerantsev criterion:

$$Po(\bar{x}, F_{O1}) = \frac{q_{VT}(\tau) \delta_1^2}{\lambda_1 t_e}. \quad (20)$$

Kirpichev Criteria:

at the edge of the formwork:

$$Ki_l(F_{O1}) = \frac{q_l(\tau) \delta_1}{\lambda_1 t_e}; \quad (21)$$

at the interface between the formwork and the medium:

$$Ki_r(F_{O2}) = \frac{q_r(\tau) \delta_f}{\lambda_2 t_e}. \quad (22)$$

The solution of the limiting value problem (8)–(11) obtained by methods of mathematical physics is given in (Fedosov, 2010). This equation is used for non-uniform initial temperature distribution and heat transfer criteria ( $Po$ ,  $Ki_l$ ), varying in coordinate and time.

The mathematical record of the solution is rather tedious.

Below is an equation for the uniform initial temperature distribution and constant values of the criteria:

$$T_1(\bar{x}, F_{O1}) = T_{1,0} + \frac{Ki_l}{6} [6F_{O1} + 3\bar{x}^2 - 1] + \frac{1}{6} Po [6F_{O1} + 3\bar{x}^2 + 1]. \quad (23)$$

Accordingly, the solution of the boundary value problem (12)–(15) will have the form:

$$T_2(\bar{x}, F_{O2}) = T_{2,0} + \frac{1}{2} \left\{ Ki_l \left[ (1-\bar{x})^2 - \frac{1}{3} \right] - Ki_r \left[ \bar{x}^2 - \frac{1}{3} \right] \right\} - [Ki_l - Ki_r] F_{O2} - \frac{2}{\pi^2} \sum_{n=1}^{\infty} \frac{1}{n^2} [Ki_l - (-1)^n Ki_r] \times \cos(\pi n \bar{x}) \exp(-\pi^2 n^2 F_{O2}). \quad (24)$$

Some results calculated according to the above equations are shown in Fig. 2.

Some results of calculations according to equations (23) and (24) are shown in Figs. 1–2. It should be noted that the calculations were done for constant values of the transfer coefficients, for greater clarity of the physicality of the processes. At the same time, when using numerical and analytical methods of calculation, to which can be referred the "zonal method" (Fedosov, 2024; Rudobashta, 2015) and the "method of microprocesses" (Fedosov, 2010; Fedosov et al., 2020), it becomes possible to create mathematical models and engineering calculation methods of heat and mass transfer processes occurring at any dependencies of thermophysical

Table 1. Hardening parameters of concrete mixture during erection of 2.0 m diameter piers

$t_{c.m.}, ^\circ\text{C}$	$t_{aver}, ^\circ\text{C}$	$t_{max}, ^\circ\text{C}$		$\Delta t$ at $t_{max}, ^\circ\text{C}$	Time of gaining strength $R = 0,7R_{28}, \text{h}$	
		core	surface		core	surface
10	5	66	46	20	56	72
10	10	69	49.5	19.5	56	70
15	10	73	52	21	48	54
15	15	75.5	56	19.5	48	54
20	20	82	62	20	40	48

coefficients on temperature and humidity of the material and the external environment. It should also be noted that these methods allow us to use the originated mathematical models with the reference to available experimental information on the kinetics and dynamics of thermal effects of hydration reactions in the medium of hardening concrete mass (Usherov-Marshak, 2002). Some data illustrating and supporting these opportunities are presented below in the *Results and Discussion* section.

**Subject matter, Purposes and Methods of the Study**

The impact of the temperature factor on such basic properties as frost resistance, water resistance, strength and cracking resistance of hardening concrete has been studied with the use of a special software package “ZA” (Solovyanchik et al., 1992) for calculation of temperature changes and strength

of hardening concrete. It has been established that when the surface modulus of the structure is less than  $5 \text{ m}^{-1}$ , a temperature gradient of more than  $10 \text{ }^\circ\text{C}$  in the concrete structure is observed. This gradient is even more critical at edges and faces as well as at the other corner areas of the structure, which should be used as a reference for setting of time for demoulding of the element covered with concrete. Otherwise, underestimation of the non-uniformity of concrete heating can lead to early freezing of the material and to surface cracks formation (Solovyanchik et al., 1989; Kollegger et al., 2018).

When the structure is massive with a surface modulus below  $2.0 \text{ m}^{-1}$ , there is a problem with high concrete warm-up, limits of which to ensure the design frost resistance are  $70 \text{ }^\circ\text{C}$  for non-surface conditions of the structure and  $80 \text{ }^\circ\text{C}$  for severe conditions (Baluchik et al., 2012).

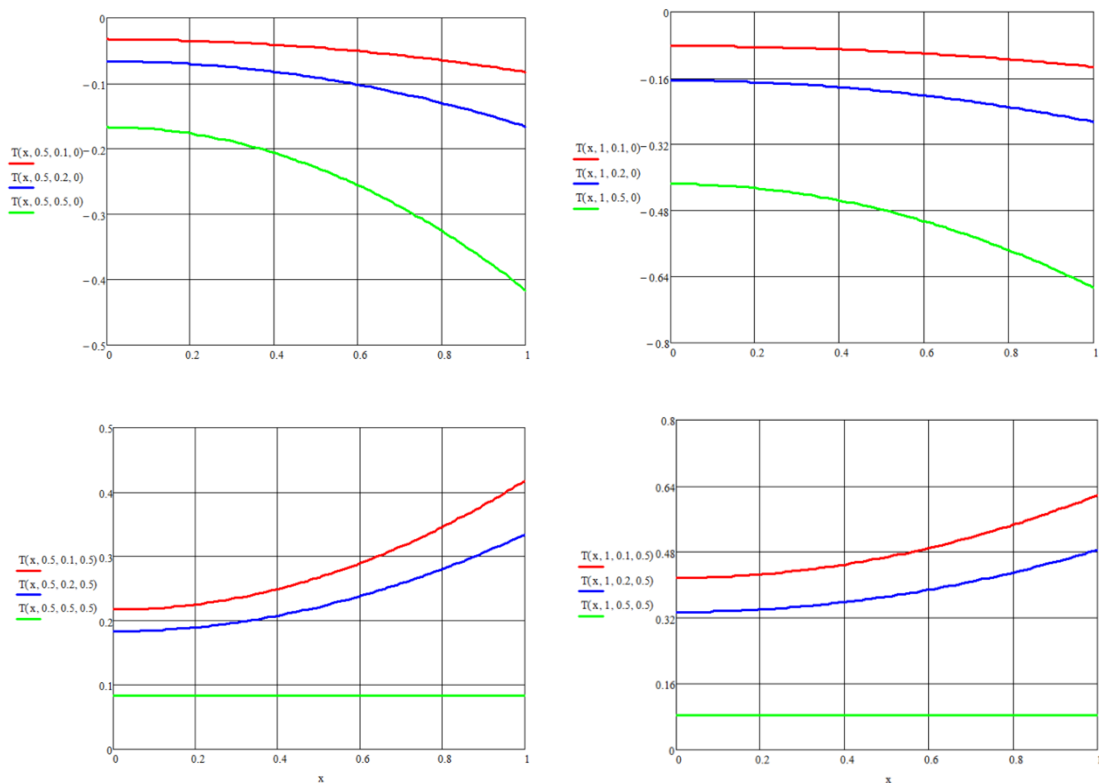

Fig. 2. Uniform initial distribution: a)  $T_0 = 0, K_1 = 0.1; 0.2; 0.5. F_0 = 0.5; P_0 = 0$ ; b)  $T_0 = 0, K_1 = 0.1; 0.2; 0.5. F_0 = 1; P_0 = 0$ ; c)  $T_0 = 0, K_1 = 0.1; 0.2; 0.5. F_0 = 0.5; P_0 = 0.5$ ; r)  $T_0 = 0, K_1 = 0.1; 0.2; 0.5. F_0 = 1; P_0 = 0.5$

The nature of temperature non-uniformity, which arises, for example, in pillars construction of a diameter of 2.0 m (surface modulus of  $2.0 \text{ m}^{-1}$ ) may be explained by the data from Table 1, which show that the problem of concrete heating decrease in structures of this type arises at a medium temperature above  $10 \text{ }^\circ\text{C}$ .

The current solution to the problem of reduction of concrete heating consists mainly in the timely prediction of maximum temperatures in specifically considered units or elements of a transport structure, since the performed researches allowed to identify modern modifiers, which provide reduction of concrete heating either by slowing down the hydration process at a certain stage of its hardening, or by using super plasticizers or organo-mineral complexes, which provide the possibility of essential reduction of the concrete heating. On top of this, calorimetric measurements of the heat release of concrete have shown that the reduction in the heating of concrete is directly proportional to the reduction in the cement consumption in it.

In order to illustrate the effect of introduction of organomineral additives into the concrete composition, Fig. 3 shows the change of temperatures in the process of its hardening during the thermophysical calculation of the foundation slab of a residential building with a thickness of 1500 mm and the foundation slab of the air terminal building with a thickness of 1400 mm. In the first instance, the concrete class was assumed to be B40 and a complex modifier such as “Embelit” was used in the selection of concrete mix composition; and in the second instance, when the design class of concrete was B35, only traditional super plasticizer and air-entraining agent were used in its composition.

## Results and discussion

Comparison of the presented data shows that during construction of the foundation slab with the use of concrete based on the modifier “Embelit 8-100” the maximum heating as a result of exothermic processes occurring during the hardening of cement in the core of the foundation slab is  $9\text{...}14 \text{ }^\circ\text{C}$  lower than in similar situation with the use of traditional composition concrete, even despite the higher class of concrete and greater thickness of the structure under consideration (Fig. 4).

The second important impact of the temperature factor for provision of marketable properties of concrete is associated with conditions of formation of its own thermal stress state, which is determined by the specifics of the impact on the structural formation of the matrix and by temperature increase in the volume of the structure during its hardening, depending on external and internal heat and mass exchange processes occurring in the concrete structure.

The emergence of thermal stressed state of concrete is explained by the fact that due to the process of uneven distribution of temperature gradient over the maximum cross-section of the concreted structure, its individual elements (as a rule, ribs and faces) undergo significant deformations. Under the conditions of the ongoing concrete hardening process, despite the fact that he observed difference in strain magnitude is recorded, the strain changes are not clearly demonstrated. This ultimately leads to formation and separation of residual (intrinsic temperature) stresses, which in certain conditions are the main cause of intensive and uncontrolled cracking.

Prof. V.S. Lukyanov (Lukyanov and Denisov, 1970) in the old days experimentally proved that the

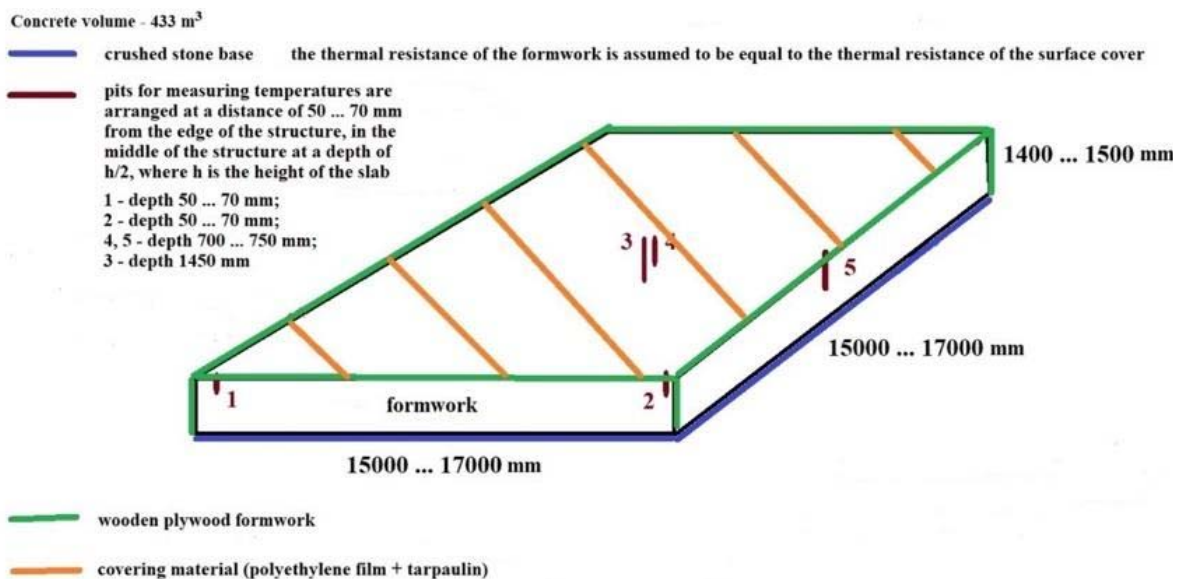

Fig. 3. Schematic diagram of the foundation slab

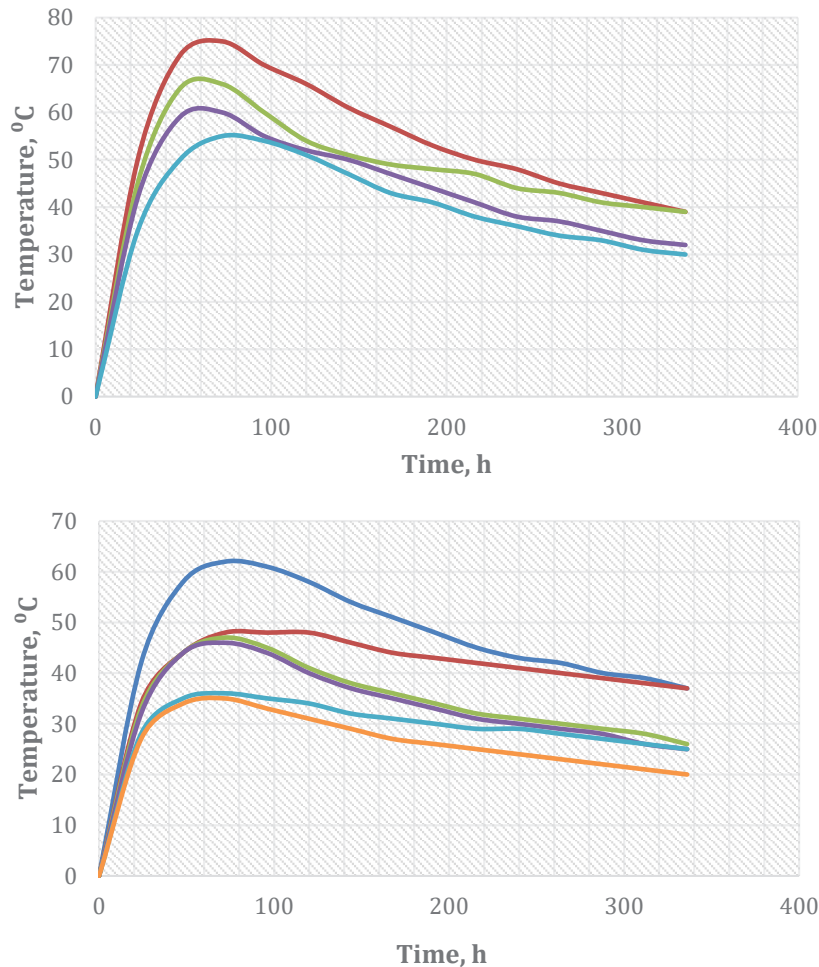

Fig. 4. Graphs of temperature gradient in concrete hardening during construction of foundation slabs with the use of different types of concrete: a) 1400 mm thick (concrete class B35, without special modifiers); b) 1500 mm thick (concrete class B40, with "Embeilit 8-100" modifier).

intrinsic temperature macro stresses in a concreted structure should be considered at the moment of temperature gradient equalization in its entire mass and under the condition of absence of external mechanical effects and phenomena of uneven shrinkage throughout the thickness during this period of time. Prof. V.S. Lukyanov proposed and later justified the hypothesis, according to which the nature and magnitude of the effect of intrinsic temperature stresses has a direct dependence on the formed temperature gradient across the cross-section of the concrete structure, while at this point in the structure such stresses are completely absent. This temperature distribution is called the temperature field (or more often - temperature curve) of zero stresses. A diverse understanding of the nature of emergence of thermal stress state under the direct impact of the temperature factor on the concrete structure, conducted by Prof. A.R. Solovyanchik (Lukyanov and Solovyanchik, 1972), showed that the time of formation of the temperature curve of zero stresses corresponds to the time of transition of primary unstable structures

from hydrosulfoalumoferritic and hydroalumoferritic new formations into secondary stable ones from calcium hydrosilicates in zones of the structure with the greatest lag in temperature. At this time, the strength of concrete is in the range of 25...30 % of  $R_{28}$  (Solovyanchik et al., 1994).

Estimation of the concrete's own thermal stress state is made by the calculated temperature difference between the most and the least heated zones of the structure, which is calculated by reduction of the temperature difference at the most unfavorable temperature distribution over the cross-section of the structure by the temperature difference at the moment of formation of the temperature curve of zero stresses. An example of such estimation can be traced on the characteristics of concrete mixture hardening in the columns of channel piers of the bridge crossing over the Oka River, presented in Table 2.

The calculations of this structure, which has a surface modulus  $M_n = 0.95 \text{ m}^{-1}$ , showed that at the consumption of cement per cubic metre of concrete mixture equal to  $425 \text{ kg/m}^3$  in both winter and summer periods of the year during the placement



**Table 2. Values of concrete intrinsic thermal stress state during construction of bridge supports piers over the Oka River in Nizhny Novgorod Region**

Calculation parameters			Formwork design		Maximum heating temperature, °C		Temperature gradient, °C			Time of cooling down to acceptable temperature, day
Cement consumption, kg/m <sup>3</sup>	t <sub>concrete</sub> , °C	t <sub>aver</sub> , °C	steel w/o heat insulation	steel with heat insulation	surface	core	at strength of 0.3 R <sub>28</sub>	at the moment of maximum heating	design	
425	9	4	+	-	29	72	16	42	25	2,9
425	9	4	-	+	64	74	1	9	7	6,4
425	18	18	+	-	27	74	11	46	34	1.9
425	19	19	-	+	61	85	8	23	14	4.4
375	9	4	+	-	24	56	11	31	19	2.9
375	9	4	-	+	39	52	3	12	8	4.4
375	18	18	+	-	34	67	9	32	12	1.6
375	19	19	-	+	49	67	5	16	10	3.4

of concrete mixture in the formwork made of metal, the value of non-uniform temperature distribution in the concrete appeared to be the most dangerous, first of all, in terms of the probability of formation of temperature cracks in the structure, because the temperature difference exceeded 15 °C. Additional heat insulation of the formwork system makes it possible to provide the required temperature differences, which in this situation vary within 9...16 °C.

It is obvious that the achievement of a greater effect on reduction of the gradient of uneven heating of concrete in the process of its hardening in the construction of low-mass bridge piers is directly achieved with a systematic reduction in cement consumption from 425 to 375 kg/m<sup>3</sup> respectively. In this case, when concrete works are carried out in the hot period, the permissible temperature difference can be guaranteed without additional formwork insulation, including steel formwork.

The intrinsic thermal stress state of concrete has a direct impact on the quality and reliability not only of individual elements of the erected structure covered with concrete, but also on the specified properties of concurrently concrete-enveloped, diverse in mass and configuration elements, as well as on the force interaction of the considered element with the previously concrete-enveloped element. This interaction as a rule takes place at stage-by-stage construction of tunnels, bridges, other facilities, when at each subsequent stage of concreting the hardened concrete becomes "restrained" by the previously placed and hardened concrete, and this restraint, limiting the manifestation of free deformations of hardened concrete, leads to emergence of thermal stresses, the value of which forms the maximum allowable size of the concrete structure and, accordingly, the distance between the construction joints, at which it does not form defects and cracks.

The distance between construction joints is directly related to the permissible temperature

difference in the mass of hardening concrete, as well as in the zone of restraint into the foundation, which, in the event of assessment of the intrinsic thermal stress state of concrete, occurs at the time when the concrete forms a secondary structure of calcium hydrosilicates, i.e. when the strength of hardening concrete in this zone is 25...30 % of the strength at the age of 28 days R<sub>28</sub>.

The performed calculations have shown that if the temperature difference between the concrete placed in the formwork in the restrained zone and the foundation at the moment when the concrete has gained strength equal to 30 % of the strength R<sub>28</sub>, not more than 20 °C, the acceptable length of the blocks to be covered with concrete shall not exceed 15–17 m. However, contrary to this, a proper thermo-physical expertise of the emerging temperature conditions of concrete hardening is not provided during development of design documentation (MS), as a result of which the sizes of concrete blocks are often assigned arbitrarily, in relation to which through-temperature cracks with opening width up to 1.0 mm are inevitably formed in the erected structure at the commencement of active operations.

At present a number of thermal engineering methods have been developed, including by the authors, which help to carry out pouring of blocks restrained in the base up to 35 m long, and in the event of the possibility of partial concrete compression — up to 50 m long. The proposed methods were used for concreting of walls and slabs (with the length 30–35 m) of a number of tunnels in Moscow, which provided almost one and a half times reduction of the construction time of these facilities in critical segments of the schedule of concrete works.

The need to consider the probability of temperature cracks and develop appropriate measures to eliminate and minimize them often arises during simultaneous concreting of structures with elements of different massiveness, for example, during the construction of overpasses with slab-and-ribbed spans.

In structures of such type, there are significant variations during concrete heating, which, on the one hand, lead to formation of significant heterogeneity in its physical and mechanical characteristics, and on the other hand, require additional assessment of the interaction between intrinsic thermal stress states of the bearing rib and the slab part of the span structure.

In this situation, the problem of thermal stress reduction may be solved with the use of formwork systems and additional thermal and moisture protective coatings with variable thermal resistance of thermal insulation, the values of which are set by a special thermophysical calculation. Such approach ensures complete elimination of cracking during construction of overpasses with slab-on-ribbed spans, and it has been implemented at various transportation facilities.

In addition to the temperature factor, formation of structural properties of concrete is primarily impacted by the process of heat and mass transfer during its placement in the concrete structure being erected. One of the most important factors from this point of view is the process of moisture exchange between the exposed concrete surface and the environment. Underestimation of this process can lead to plastic shrinkage of concrete and, as a consequence, to irreversible process of moisture loss of the whole erected massif.

Thermal and humidity regime of the concrete of a structure during its construction plays an almost dominant role in formation of stresses arising in concrete and leading to its shrinkage and plastic deformations, as well as in the process of determination of physical and mechanical properties of the hardening concrete. These features have a direct impact on the periods of interruption in the overlay of concrete mixture layers, and this factor directly depends on many factors, one of which is the shape of the structure, its architectural design features, speed of placement of the concrete mixture into the formwork, guarantee of uninterrupted logistic flows, as well as variability of concrete and environmental temperatures, including the factor of solar radiation, also directly affecting the level of moisture loss. These factors shall be taken into consideration during approval of restrictive measures for construction works.

The conducted studies have allowed to establish that the period of direct environmental impact on the concrete surface in the process of its hardening should be regulated by the time period from the start of the concrete placement into the formwork until the moment when moisture loss by the end of the process of overlapping layers does not exceed for concrete class B30 — 10.5 % of the volume of mixing water and 10 % — for concrete class B40. The above remark is valid provided that the

workability of the concrete mixture previously placed in the formwork system is not less than 2.5 cm of the Abrams standard cone settlement, and the time of joint vibro-compaction of two adjacent layers varies within the limits equal to 25...30 s. At the same time for the top - the final layer of concrete mixture to be placed in the formwork system, the allowable level of the moisture loss, at which the gain of the design strength of concrete is guaranteed with a security of 0.98, and there is no reduction in the grade of concrete frost resistance, is about 6.9 % of the volume of mixing water for concrete class B30 and 6.4 % — for concrete class B40.

The adopted limits on the permissible moisture loss boundaries allowed to outline the optimum period of environmental exposure on the poured concrete. The results are presented in Table 3.

The critical challenge related to the care and handling of fresh concrete by the time the formwork is completed and the exposed surface of the structure is finished can be divided into two key sub-challenges.

The first is the need for absolute elimination of further moisture loss from the concrete surface. Bearing this in mind, the hardening concrete maintenance period shall be calculated according to the time of critical strength gain relative to moisture loss in the surface layers of the placed concrete. The physical determination of the values of this parameter is recommended to be carried out on the concrete mixture compositions selected in advance in laboratory conditions and planned for use. If performance of such tests is unavailable, the above value should be taken as 75 % of the concrete strength at  $R_{28}$  age.

Implementation of the method described above shall be carried out by covering the exposed concrete surface of the structure under consideration with prepared polymeric materials, which are fixed on the concrete surface as appropriate.

The second sub-challenge is to ensure the required conditions for formation of temperature homogeneity across the cross-section of the erected structure. For its solution, it is sufficient to use various covering materials having a certain thermal resistance, the number of layers of which, including an additional layer of PE film protecting the covering material from getting wet, shall be determined in advance by a special thermo-physical calculation.

It should be noted that pooled data on methods of reduction of the degree of inhomogeneity of concrete temperatures in different massiveness of elements can only be indicative. Therefore, for each newly designed structure, it is necessary to carry out individual calculations on simulation models in search for options that ensure exclusion of formation of through-temperature cracks.

Table 3. Regulated period of environmental exposure of the concrete surface when the structure is concreted in layers

No	Concrete class	Concrete structure temperature, °C	Medium parameters			Regulated period of environment exposure, min	
			temperature, °C	mobility, m/s	radiation, W/m <sup>2</sup>	top layer	layer-by-layer laying
1	B30	14	9	-	-	115	146
2	B30	18	24	-	-	35	87
3	B30	19	25	1.0	-	22	24
4	B40	14	9	-	-	145	175
5	B40	19	24	-	-	37	62
6	B40	20	25	1.0	-	19	29
7	B40	21	26	1.0	300	21	31
8	B40	22	27	0	300	27	38

### Conclusions

The described features of the impact of processes related to thermal physics on ensuring the necessary structural properties of transportation structures should be taken into consideration in the development of process regulations as part of Method Statements, which are an integral part of the industry quality management system in relation to transportation infrastructure facilities.

The primary goal of the developed rules for a particular construction facility is to determine and fix the conditions and techniques that ensure reduction of defects and cracks, including in conditions of discontinuity of technical processes, and with reference to compliance with the requirements to ensure performance of work at a fast pace.

It is important to note that the implementation of these techniques, depends on availability of research and technical support of the construction of transport infrastructure structures, the main purpose of which is to validate reliability of the decisions on the formation of the specified structural properties of concrete in practice with possibility of making operational adjustments to the decisions taken (if appropriate), with reference to thermophysical processes, which is directly evidenced by a sufficient degree of coincidence between the calculated and experimentally obtained data on the temperature difference of concrete during hardening at those facilities where this support was carried out, as well as absence of defects and cracks in structures for which the provisions of process regulations were perfectly observed.

## References

- Balyuchik, E. A. and Chernyi, K. D. (2010). Increasing crack resistance of monolithic concrete bridge supports by structural methods. *Collection of scientific papers of the Central Research Institute of Structural Engineering*, No. 257, pp. 49–57.
- Balyuchik E.A., Velichko V.P., and Chernyi K.D. (2012). Manufacturing of facing blocks in winter period of bridge construction across the river Angara. *Transport construction*, No. 10, pp. 4-7.
- Concu, G. and Trulli, N. (2018). Concrete defects sizing by means of ultrasonic velocity maps. *Buildings*, Vol. 8, Issue 12, pp. 176. DOI: 10.3390/buildings8120176.
- Evlanov, S. F. (2002). Technological cracks on the surface of monolithic span structures. *Scientific works of JSC CRITC "Problems of standardization and research of consumer properties of bridges"*, No. 208, pp. 27-36.
- Fedosov, S. V. (2010). Heat and mass transfer in technological processes of the construction industry: Monograph. Ivanovo: IPK "PressTo". p. 363.
- Fedosov, S. V. (2024). Methods of the Theory of Heat Conduction in Applications to Problems of Modeling the Processes of Drying and Heat Treatment of Solid Materials: Monograph. Moscow, Vologda: Infra-Engineering. p.212.
- Fedosov, S. V. and Mizonov, V. E. (2020). Fundamentals of the theory and mathematical modeling of mechanical and thermal processes in the production of building materials, Switzerland: Palmarium Academic Publishing. p. 256.
- Ginzburg, A. V. (2014). Ensuring high quality and efficiency of the works in the process of constructing the tunnels of in-situ concrete. *Vestnik MGSU*, No. 1, pp. 98–110.
- Kollegger, J., Kromoser, B., and Suza, D. (2018). Erection of bridges and shells without formwork-challenges for the computational modeling. *Computational Modeling of Concrete Structure*, pp. 43-54. DOI: 10.1201/9781315182964-4.
- Komandrovsky, A. F. (2003). Experience in constructing span structures from monolithic prestressed reinforced concrete. *Bulletin of Bridge Construction*, No. 3–4, pp. 24–29.
- Kosmin, V. V. and Mozalev, S. V. (2014). Problems of research, design and construction of large-span bridges. *Bulletin of Bridge Construction*, No. 1, pp. 19–24.
- Lukyanov, V. S. and Denisov, I. I. (1970). Calculation of thermoelastic deformations of massive concrete bridge supports for the development of measures to improve their crack resistance. *Collection of scientific papers of the Central Research Institute of Structural Engineering*, No. 36, pp. 4-43.
- Lukyanov, V. S. and Solov'yanchik, A. R. (1972). Physical bases of forecasting proper thermal stress state of concrete and reinforced concrete structures. *Collection of scientific works of the Central Research Institute of Structural Engineering*, No. 73, pp. 36-42.
- Passek, V. V., Zakovenko, V. V., Antonov, E. A., and Efremov, A. N. (2002). Application of artificial cooling in the process of temperature control of erected reinforced concrete arches. *Scientific works of JSC CRITC "From hydraulic integrator to modern computers"*. No. 213, pp. 73–75.
- Prjakhin D.V. (2009). Investigation of stay cable span bridge structure work by physical modelling. *Transport construction*, No. 10, pp. 11–13.
- Rudobashta S. P. (2015). Thermal Engineering. Moscow: "Pen". p. 672.
- Sokolov, S. B. (2002). The influence of air temperature fluctuations in greenhouses on the temperature of hardening concrete during the construction of monolithic slab-ribbed span structures in the cold season. *Scientific works of JSC CRITC "From a hydraulic integrator to modern computers"*, No. 213, pp. 167-172.
- Solov'yanchik, A. R., Shifrin, S. A., Ilyin, A. A., and Sokolov, S. B. (2006). Selection of technological parameters for the production of concrete works during the construction of massive grillages and supports of the arch pylon of the cable-stayed bridge across the Moskva River. *Scientific works of JSC CRITC "Research of transport structures"*. No. 230, pp. 24-30.
- Solov'yanchik, A. R. and Shifrin, S. A. (2000). Management of thermally stressed state of monolithic reinforced concrete structures in high-speed year-round construction of transport facilities. *Scientific works of the Central Research Institute of Structural Engineering*, No. 203, pp. 25–32.

- Solov'yanchik, A. R., Korotin, V. N., Shifrin, S. A., and Veitsman, S. G. (2002). Experience in reducing crack formation in concrete from temperature effects during the construction of the Gagarin Tunnel. *Bulletin of Bridge Construction*, No. 3-4, pp. 53-59.
- Solovyanchik, A. R., Krylov, B. A., and Malinsky, E. N. (1994). Inherent thermal stress distributions in concrete structures and method for their control. Thermal Cracking in Concrete at Early Ages. *Proceedings of the International RILEM Symposium. Munich*. pp. 5.
- Solov'yanchik, A. R., Shifrin, S. A., Korotin, V. N., and Veitsman, S. G. (2003). Implementation of the concept of "quality" in the construction of the Gagarin tunnel in Moscow. *Scientific works of JSC CRITC "Technologies and quality of erected structures from monolithic concrete"*, No. 217, pp. 206-212.
- Solov'yanchik, A. R., Velichko, V. P., and Zorina, V. A. (1992). Development of a new methodology for studying the temperature regime, strength of hardening concrete and thermal stress state of transport structures using a PC. *Collection of scientific papers of the Central Research Institute*, No. 112, pp. 75–77.
- Solov'yanchik, A. R., Velichko, V. P., and Zorina, V. A. (1989). Calculation of thermal and thermally stressed state of concrete and reinforced concrete structures with modified geometry during their manufacture. (ZA200). *Collection of scientific papers of CRITC*, No. 108, pp. 10–15.
- Tarasov, A. M., Bobrov, F. Yu., and Pryakhin, D. V. (2007). Application of physical modeling in the construction of bridges and other structures. *Bulletin of Bridge Construction*, No. 1, pp. 21–26.
- Usharov-Marshak, A. V. (2002). *Calorimetry of cement and concrete*. Kharkov: Selected works. p.180.
- Vasiliev, A. I. and Veitsman, S. G. (2015). Modern trends and problems of domestic bridge construction. *Bulletin of Bridge Construction*, No. 1, pp. 2–17.
- Velichko, V. P. (1987). Methodology of using hydraulic analogies of V. S. Lukyanov in developing an algorithm and solving transport construction problems on a computer. *Collection of scientific papers of the Central Research Institute of Structural Engineering*, No. 100, pp. 15–22.
- Velichko V.D. and Chernyi K.D. (2013). Consideration of stress-strain state in precast monolithic bridge pillars at its construction. *Transport construction*, No. 2, pp. 11–13.
- Xu, G., He, C., Lu, D., and Wang, S. (2019). The influence of longitudinal crack on mechanical behavior of shield tunnel lining in soft-hard composite strata. *Thin-Walled Structures*, Vol. 144, pp. 106282. DOI: 10.1016/j.tws.2019.106282.
- Zvorykin, A., Mahdi, M., Popov, R., Barati, F. K., and Piro, I. (2017). Heat transfer to supercritical water (liquid-like state) flowing in a short vertical bare tube with upward flow. *International Conference on Nuclear Engineering. London, England: Proceedings, ICONE 9*. pp. 14. DOI: 10.1115/ ICONE26-81608.

## ТЕПЛОФИЗИЧЕСКИЕ ПРОЦЕССЫ В ТВЕРДЕЮЩЕМ БЕТОНЕ КАК ФАКТОР ОБЕСПЕЧЕНИЯ КАЧЕСТВА ВОЗВОДИМЫХ ЖЕЛЕЗОБЕТОННЫХ КОНСТРУКЦИЙ ТРАНСПОРТНЫХ ОБЪЕКТОВ

Сергей Федосов<sup>1</sup>, Иван Пуляев<sup>2\*</sup>, Ольга Александрова<sup>1</sup>, Надежда Чередниченко<sup>3</sup>, Евгения Дербасова<sup>2</sup>, Юлия Лежнина<sup>4</sup>

<sup>1</sup>Национальный исследовательский Московский государственный строительный университет, г. Москва, Россия

<sup>2</sup>Московский политехнический университет, г. Москва, Россия

<sup>3</sup>Российский университет транспорта (МИИТ), г. Москва, Россия

<sup>4</sup>МИРЭА – Российский технологический университет (РТУ МИРЭА), г. Москва, Россия

\*E-mail: ivanes50@mail.ru

### Аннотация

**Введение.** В настоящей статье рассмотрены основные вопросы обеспечения конструкционных свойств бетона в зависимости от воздействия на него температурного фактора и теплообменных процессов в контакте с окружающей средой при строительстве транспортных объектов, возводимых из монолитного железобетона при различных начальных и граничных условиях. **Цель исследования:** обеспечение качества предпроектных исследований железобетонных конструкций, включающих натурное моделирование рассматриваемых теплофизических процессов в твердеющем бетоне, в том числе с использованием современных расчётно-аналитических комплексов. **Методы.** Применение специального программного комплекса для расчета изменения температур и прочности твердеющего бетона, оценки влияния температурного фактора на обеспечение свойств бетона: морозостойкости, водонепроницаемости, прочности и трещиностойкости. **Результаты.** Показано, что учёт термонапряженного состояния твердеющего бетона позволяет гарантированно обеспечить требуемые эксплуатационные свойства конструкций: качество, надежность, долговечность, в том числе в части недопущения появления температурных и усадочных трещин, как одних из самых распространенных в настоящее время в транспортном строительстве дефектов, снижающих качество возводимой поверхности. Описанные в настоящей статье исследования были неоднократно апробированы на транспортных объектах России в Москве, Санкт-Петербурге, на Кубани и в Крыму, других областях и нашли широкий отклик в транспортной индустрии. Статья будет интересна и полезна лицам, интересующимся процессами обеспечения бездефектного бетонирования разномассивных конструкций транспортных объектов, а также инженерно-техническим работникам, занятым в реальном секторе строительства.

**Ключевые слова:** бетон; температурные напряжения; теплофизические процессы; трещиностойкость; модуль поверхности конструкции.

# CONSTRUCTION METHOD AND APPLICATION OF A BASIC DIGITAL DATABASE FOR THE INTELLIGENT MANAGEMENT AND MAINTENANCE OF EXISTING RAILWAY TUNNELS

Haiying Lv<sup>1,2\*</sup>, Lei Wang<sup>3</sup>, Huilin Yang<sup>1,2</sup>, Ruijie Sun<sup>1,2</sup>, Jin Yang<sup>4</sup>

<sup>1</sup>CCCC Rail Transit Technology R & D Center, Beijing, China

<sup>2</sup>Rail Transit Branch of China Communications Construction Co., Ltd, Beijing, China

<sup>3</sup>Shenshuo Railway Branch of China Shenhua Energy Co., Ltd., Yulin City, China

<sup>4</sup>China Communications Railway Design and Research Institute Co., Ltd, Beijing, China

\*Corresponding author's email: 121910470@qq.com

## Abstract

**Introduction:** China has an extensive network of tunnels requiring maintenance. An intelligent management and maintenance of these tunnels based on a digital information system can be useful. To this end, it is necessary to collect relevant digital information regarding the tunnel body and surrounding environment for long-term maintenance. **The purpose of the study** was to take an existing operational tunnel as the research subject; this study applied various information technology methods to construct a basic digital database for the intelligent management and maintenance of tunnels. **The following methods** were used: data statistics, drone aerial photography, ground penetrating radar, full-section laser scanning and theoretical analysis. As a **result**, the database can be used as a reference for similar projects.

**Keywords:** smart management and maintenance; digitization; basic database; aerial photography; full-section laser scanning; ground penetrating radar.

## Introduction

According to statistics, as of 2022, China has operationalized a total of 17873 railway tunnels covering approximately 21987 km (Gong et al., 2023). With this, China has become a major country with a large number of tunnel maintenance tasks, and an intelligent management and maintenance of these tunnels based on the principles of digitization has become a necessary path. With the proposal of smart cities, smart management and maintenance technologies are gradually being developed. Currently, China mainly focuses on the development of new tunnels. For old tunnels, particularly those built before 2000 (a total of approximately 6887 tunnels with a total length of 3667 km) (Tian et al., 2021), the design drawings and other construction materials are mostly hand-drawn versions.

Establishing a basic database for digital smart management and maintenance of tunnels, and obtaining existing and historical data that can truly and comprehensively reflect the state of tunnels are key research directions, and these are discussed in this study. Conventional tunnel maintenance is largely based on the long-term understanding and tracking of tunnel diseases by maintenance personnel. This approach strongly relies on the skill and experience of the personnel, sense of responsibility, and business skills. Although there are qualitative and quantitative descriptions, such as in the form of maintenance records, they cannot help track and evaluate diseases

or other anomalies appearing in the tunnel. Carrying out full lifecycle operation and maintenance based on digital monitoring can help objectively record the entire process of disease formation, development, and deterioration, and incorporate the experience of enterprise employees into an information system as long-term accumulated data, thus providing a strong support for decision-making (Dai, 2022). Hence, it is necessary to collect digital information regarding the tunnel body and surrounding environment for long-term maintenance.

### *Project Overview*

An existing double-track tunnel with a total length of 5804 m was considered as the research subject in this work. The construction of this tunnel started in 1989 and was completed in 1993. It was operationalized in 1996. The tunnel has been designed using the principles of the new Austrian design method, with a curved wall composite lining. The construction method was drilling and blasting, with a spray anchor support.

The following issues have been noted in the current maintenance process of this tunnel: (1) Difficulty in terms of the engineering aspects. The tunnel is not only located in a complex loess hilly terrain but also passes through multiple gullies. In terms of the complex geological conditions, it mainly passes through layers of sand and mudstone interbedded with coal seams containing abundant groundwater. Since its completion, the tunnel has

frequently seen diseases, mainly including lining damage and cracking, softening of the foundation bed, mud pouring from the base, blockage of drainage facilities, groundwater infiltration, and related issues. The tunnel underwent multiple disease treatments in 1997, 1998, 2000, 2001, and 2013. However, in recent years, tunnel diseases have continued to develop, and there is a further deterioration trend. (2) Insufficient information on the current state of the tunnel. After 30 years of operation, the surrounding environment has undergone significant changes; the tunnel now passes through multiple factories and roads and multiple coal mines below. The maintenance and testing data collected over the years are complex and inconsistent, and there is no systematic system in place, making it impossible to predict and identify the causes of existing diseases. (3) There is heavy traffic in the tunnel, and skylights are few. After the tunnel was opened, the operation of the line was busy, and the transportation pressure was very high. On average, a train passed every 8 min, and the transportation volume has increased year by year. Since 2012, the transportation volume has exceeded the 200 million ton mark for 11 consecutive years, with the highest annual transportation volume reaching 277 million tons. The difficulty and pressure in terms of transportation safety assurance, route maintenance, and equipment inspection and repair are enormous. There are few sunroof points for maintenance, and there can only be 2–3 sunroof points per week, with each sunroof point lasting 3–4 h.

In summary, to ensure the continuous safe operation of the line and ensure transportation capacity, it is necessary to establish a basic digital information system that can support operation and maintenance requirements and one that is convenient for maintenance comparison and decision-making. Furthermore, an intelligent management and maintenance technology characterized by either no personnel (unmanned) or minimal personnel and high efficiency should be developed.

#### *Construction of a Basic Digital Database for Tunnels*

##### *Basic Database Objectives*

To effectively control operational risks, ensure operational safety, and prevent tunnel diseases from affecting driving safety, it is necessary to conduct a comprehensive and systematic diagnosis of the tunnel and make necessary structural improvements. Before systematically rectifying tunnel diseases, a comprehensive and systematic digital database must be established. Based on this, analysis and diagnosis work should be performed, and the safety state of the tunnel should be evaluated to lay a solid foundation for disease treatment work.

The basic requirements in building a basic digital database (Fig. 1) for tunnels are the

comprehensiveness and accuracy of the data. To ensure the comprehensiveness of the collected data, the data must contain information related to the entire life cycle of the tunnel, mainly including historical data and the current state of the tunnel. Historical data include all tunnel-related information during its construction and operation periods. The above information should be comprehensively collected, analyzed, and organized. The current state of the tunnel includes the comprehensive external environment and the internal environment and structure of the tunnel. The comprehensive digital collection of the current state of the tunnel mainly requires an environmental investigation of the external terrain, underground mining areas, and goaf, as well as sorting out of the internal environment, structural state, and disease database of the tunnel. Data collection methods are mainly employed for this process, such as drone photography, ground penetrating radar, and 3D scanning technology. The collected data are supplemented and verified using manual tapping verification, numerical simulation, comprehensive investigation and analysis, and other methods. To ensure the accuracy of the data collection, multiple self-verification tests and mutual verification of the results obtained using conventional manual testing and information technology testing were adopted.

##### *Digitization of Historical Data*

A comprehensive understanding of the state of a tunnel requires the collection of all historical data such as geological survey data, design documents, construction inspection reports, construction logs, design change data, supervision data, and completion documents from the construction period. Moreover, it is necessary to comprehensively collect all previous inspection and maintenance data and daily operation and maintenance data during the operation period of the tunnel. Finally, all the collected information should be converted into an electronic format, and then classified, organized, and archived.

The design materials and drawings for the tunnel were hand drawn versions, while the construction materials were handwritten versions. In conjunction with the construction of a digital archive, all the materials were scanned into digital electronic files. The collected materials were sorted by year and by category (Table 1). All the handwritten excavation process data were converted into digital tables, which can be equipped with 3D models in the later stage for 3D demonstrations and data analysis of the construction process. From the analysis and organization of the historical data, it is possible to have a better understanding of the tunnel and discover many potential diseases from the beginning of its construction. For example, at that time, the design standards were low, and waterproof boards



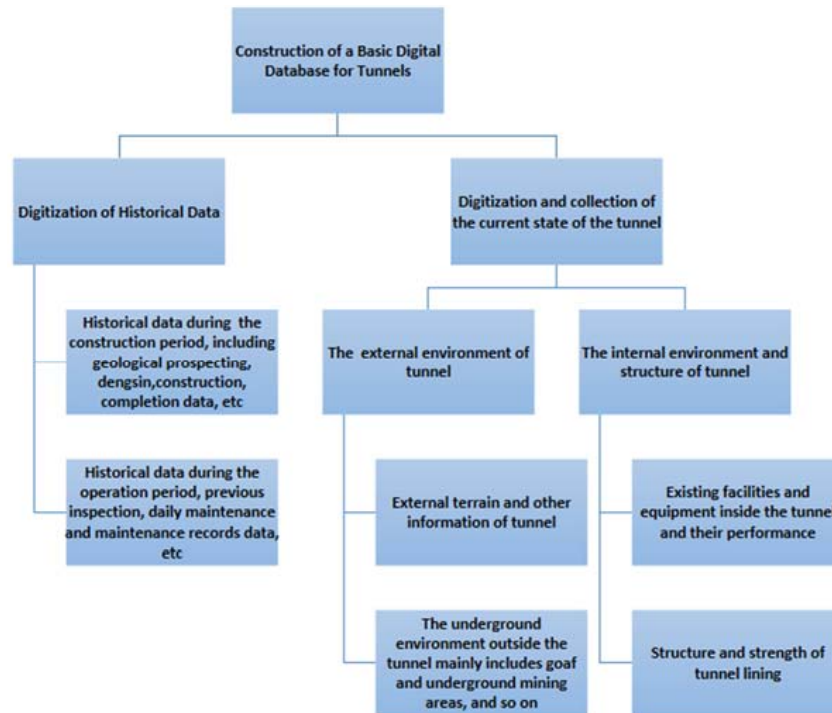

Fig. 1. Technical roadmap for the construction of a basic digital database

were not used in the lining. Waterproof measures were only used in some shallow buried trenches. The construction technology level for the lining was insufficient, and the construction conditions were limited, resulting in significant collapse and deformation during the construction process, which caused many voids behind the tunnel lining. The water temperature and geological conditions were poor, and a coal seam of 1987 m was present in the tunnel, accounting for 34.24 % of the total tunnel length. The tunnel contains abundant groundwater, including the presence of a loess tunnel groundwater

layer, which led to more diseases at the bottom of the tunnel. Inadequate supervision and lack of a supervision system during construction were also noted. The digital historical data can be accessed and retrieved at any time through the building information modeling (BIM) platform in the later stage (Sun et al., 2020).

*Digitalization and Analysis of Tunnel Environment*

For the digital acquisition of the external environment of a tunnel, drone aerial photography technology, combined with completion data and manual on-site investigation and verification

Table 1. General Catalogue of Historical Data Collection and Sorting for an Existing Operating Tunnel

Number	File Overview	Number	File Overview
1	1990 Design Documents	12	Design documents for engineering and disease control in 2001
2	Tunnel excavation construction logs from 1990 to 1993	13	Tunnel clearance survey in 2005
3	Completion data for 1996	14	2012 non-destructive testing data
4	1996 Completion Drawing	15	2013 full line re survey
5	Data on disease control in 1997	16	Completion data for disease control in 2014
6	1998 drilling data	17	Disease control in the 2014 engineering year
7	Completion data for disease control in 1998	18	2016 Disease Settlement Data (2014)
8	1998 Engineering Information	19	Renovation of Drainage Ditches and Escape Caves in 2017
9	1999 Disease Control Engineering	20	2020 Flood Control and Renovation Design Documents
10	Completion data for disease control in 2000	21	Design Document for Rectification of Corrugated Plate Diseases in 2021
11	2000 Engineering Information		

methods, was mainly adopted (Li et al., 2005). The surface topography and terrain conditions of the entire line were comprehensively determined, and existing basic data were verified and revised, laying a good foundation for a comprehensive understanding of the current state of the tunnel from the perspective of an external comprehensive environment and for future intelligent operation and maintenance work.

A comprehensive aerial photography of the ground surface was conducted within a range of approximately 200 m on both sides of the tunnel centerline using drones. External environmental data were also collected, such as terrain and topography along the tunnel, gullies, nearby factory buildings, underground mining areas, current state of entrances and exits, and burial locations and conditions of auxiliary tunnels. Based on the collected basic image data, the key terrain and topography information within the survey area were modeled and processed. Based on the collected "Tunnel Completion Map" and other drawing materials, as well as the comprehensive external environment of the tunnel collected by drones, on-site surveys were conducted to compare and verify the collected data. Key environmental features, such as important gullies, nearby factories and mines, and tunnel auxiliary tunnels, were investigated and verified (Fig. 2), to discover possible and potential harmful environments. Through a comprehensive comparative analysis, the tunnel structure below the gully was found to be prone to severe water leakage, while the tunnel structure under the factory and mine was prone to more diseases. The internal structure of the auxiliary tunnel was also severely corroded by water leakage.

The digital assets collected mainly include a set of surface panoramic orthophoto data with a total

width of 400 m on both sides of the tunnel centerline. A skewed model map (Fig. 3), displaying the current state of the tunnel surface from a full perspective, can be used as basic data for regular surface condition collection and terrain comparison measurement. In the later stage, it can be combined with the BIM to serve as basic digital data for relevant early warning systems to timely grasp the changing trends of surface diseases and to expand the digital assets of tunnels (Cheng et al., 2019). A topographic map of the tunnel was constructed as well. By combining the completed plan and longitudinal section, an electronic version of the topographic map and an electronic version of the longitudinal section can be formed.

In this inspection, the main focus was on surface data collection. Regarding underground mining areas and goafs, relevant information was mainly obtained through investigation and site visits. The relative position relationship between the tunnel and the mining area was obtained by analyzing data collected from government departments. In the later stage, special geological surveys can be conducted to address issues related to the goaf, in order to make the data more accurate and complete.

*Collecting Data of the Ontology Information of Tunnel Structure*

1) Vectorization of surface disease information inside the lining.

A full-section laser scanning technology was adopted for the digital acquisition of the internal surface of the tunnel. The purpose of using a full-section laser scanner to scan and image the tunnel lining was to collect data regarding the internal appearance and existing facilities and equipment of the tunnel, in order to meet the requirements of identifying tunnel surface diseases, detecting basic

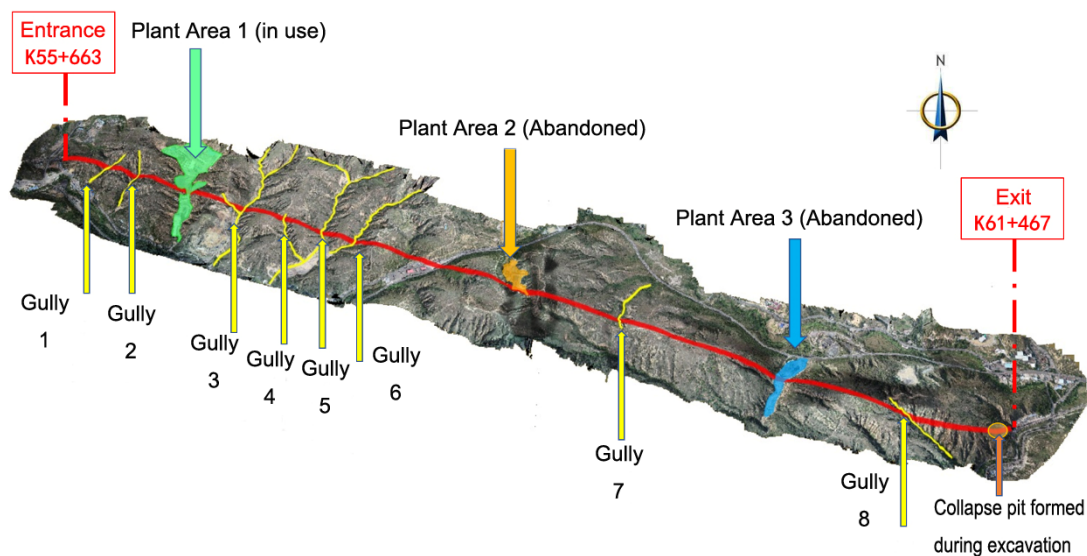

Fig. 2. Distribution of gully landform above the tunnel

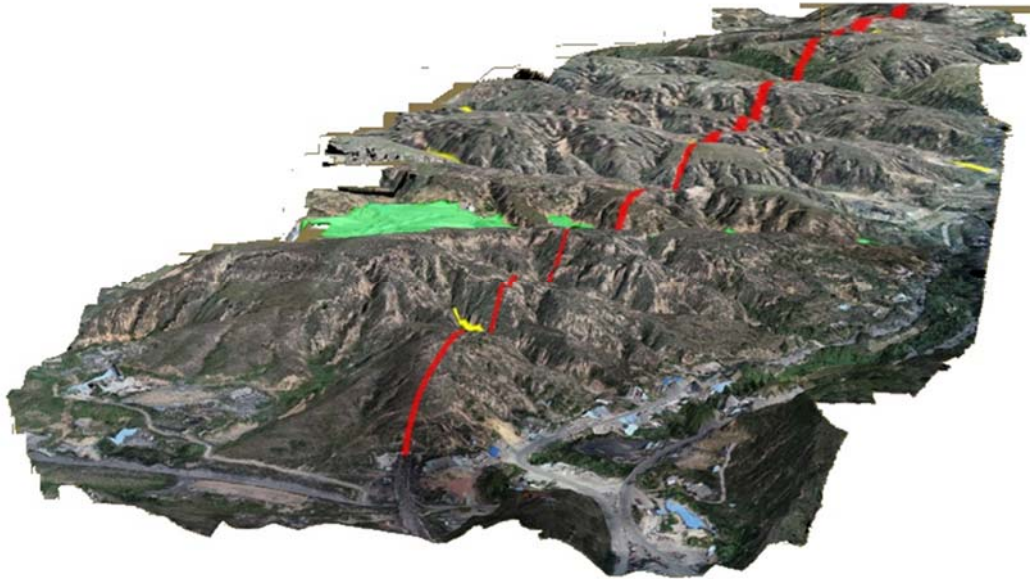

Fig. 3. Skewed 3D model results

building limits, and recording intrusion locations in the later stage. Key findings include surface cracks, cracks, misalignment, falling blocks, water leakage, foreign objects, and other surface diseases in the lining, as well as the location of tunnel intrusion limits.

The GRP5000 tunnel scanning system (Fig. 4), which is currently one of the more advanced tunnel detection technologies, was used for the digital acquisition (Wen et al., 2014). The system meets the requirements of railway tunnel clearance, convergence deformation, and surface disease detection. It integrates a manually pushed rail inspection car and a high-speed laser scanning measurement technology. This makes it suitable to rapidly detect tunnels during tunnel operation, establish digital operation archives, guide maintenance operations, and improve operation and management levels.

A laser scanner was used to perform a full-section high-density scanning of the tunnel in a spiral

shape (Fig. 5). The acquisition software gathers image information of the inner surface of the tunnel lining by analyzing the intensity of the emitted and received laser signals, forming a grayscale image (Fig. 6). By analyzing the phase difference between the emitted and received laser signals, the 2D coordinates of the scanning points on the surface of the tunnel lining can be obtained. Combined with the external absolute positioning of the total station or inertial navigation, the 3D absolute coordinates of all the measurement points can be obtained. The true unfolding map and cross-sectional contour information of the tunnel surface diseases can be



Fig. 4. GRP5000 tunnel scanning system

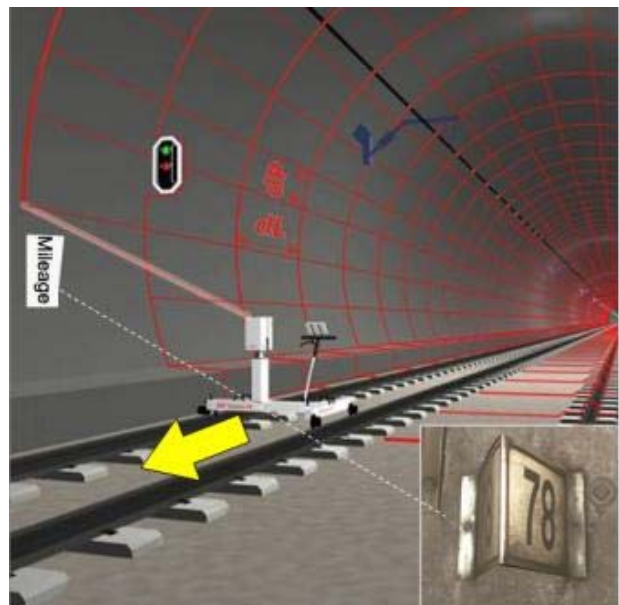

Fig. 5. Schematic of the full-section scanning of a tunnel

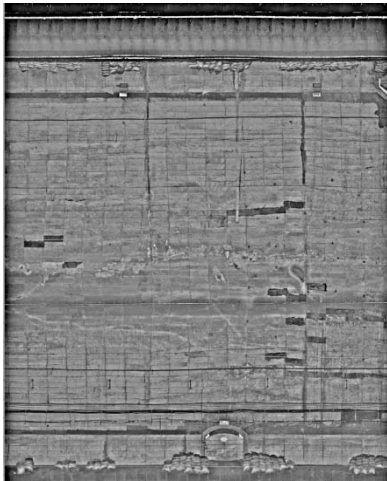

Fig. 6. Grayscale image

determined using professional post-processing analysis software (Fig. 7).

The main digital assets collected include a set of 3D point cloud data on the surface of the tunnel. This set was used for the later 3D modeling inside the tunnel, full tunnel high-definition grayscale imaging, and tunnel cross-section mapping (using a 2 m section for this project). Through a comprehensive analysis, a set of apparent disease display charts was formed.

2) Digital collection of tunnel lining structure and surrounding rock state.

In the digital acquisition of the current state of tunnel structures, the geological radar detection technology was mainly used for a comprehensive nondestructive testing of the tunnel lining structures (Shao et al., 2023). Diseases in the lining structure and surrounding rock, and other diseases, were mainly discovered.

Based on the current internal state of the tunnel, the SIR-3000 geological radar host and a 400 MHz

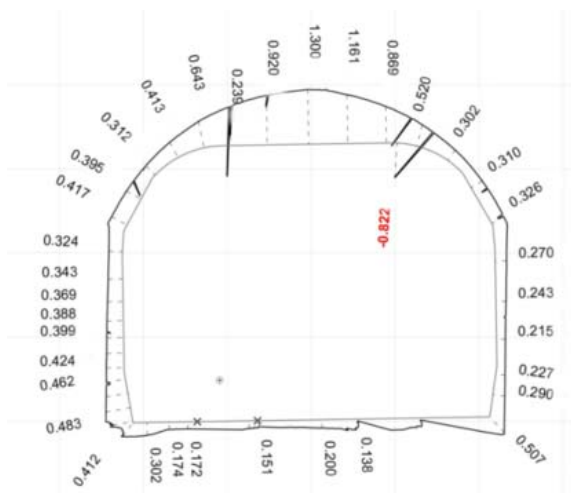

Fig. 7. Cross-sectional view Unit (m)

shielded antenna were used for detection. This radar system host is lightweight, highly automated, has stable signals, high detection speed, and high resolution. It can display the detected profiles in real time, allowing for post-processing and interpretation of the data on a computer, thus integrating the data collection and processing steps. Ten survey lines were set up throughout the tunnel (Fig. 8), including two at the bottom of the tunnel, two on its side walls, and six on the arches. The lining inside the tunnel has a significant amount of fly ash, and the existing facilities and equipment are relatively outdated, and there is a need to avoid more interference. Therefore, the method used in this study was manual small carts (Fig. 9), which can adapt well to the characteristics of the coal transportation line in the tunnel. This method can not only closely adhere to the tunnel wall but also timely avoid old facilities,

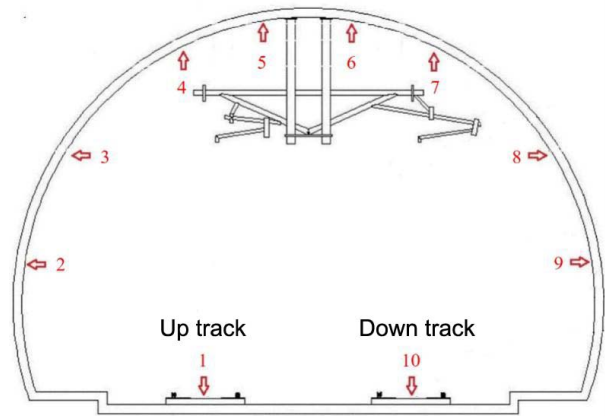

Fig. 8. Schematic of the geological radar

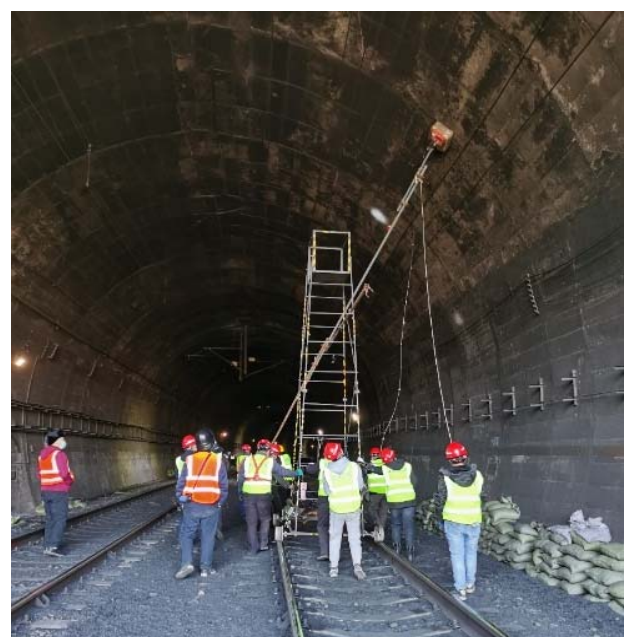

Fig. 9. Ground penetrating radar detection of tunnel lining

and the detected data are accurate and reliable. The detected contents mainly include the thickness of the tunnel secondary lining, void and non-dense distribution inside and behind the secondary lining, cracks and water accumulation on the tunnel floor, and other issues.

A set of ground penetrating radar data was obtained, including information related to the position, shape, structure, and size of the detected target body. Clear and interpretable geological radar image profiles were generated through data processing. A search for areas in the radar wave spectrum where the reflection wave has discontinuous in-phase axes produced bending, strong reflection wave energy, and strong echo amplitude response. Based on the phase, frequency, and amplitude changes of the radar waves, a comprehensive qualitative judgment was made, and the density of the backfill (or grouting) behind the lining, the thickness of the lining, and the distribution of steel frames and steel bars inside the lining were ultimately determined.

The digital assets collected include a set of geological radar data, clear and interpretable geological radar image profiles, and typical disease images inside (behind) the lining (Fig. 10).

3) Concrete strength data collection at a typical section.

A digital collection of the concrete strength data for tunnel lining was performed using a concrete rebound meter for testing. In accordance with the standard, each detection point was located 50 m away, and 234 detection areas were tested along the entire line. By revising, a table of the concrete strength for the entire tunnel was formed, and areas with insufficient concrete strength were identified. A total of 60 tested areas were found to have

insufficient concrete strength (Fig. 11), including 29 upstream side walls and 31 downstream side walls.

The HT-225A concrete rebound tester was used. It complies with the relevant provisions of the national standard GB/T9138-2015 “Rebound Tester,” JJG817-2011 “Rebound Tester Verification Technical Regulations,” and TB10426-2019 “Railway Engineering Structure Concrete Strength Testing Regulations.” This tester is suitable for testing the strength of general building components, bridges, and various concrete components (slabs, beams, columns, and bridges)

*Information integration*

*Tunnel Disease Statistics*

The main focus of the inspection was tunnel lining diseases, and the types of tunnel diseases detected are summarized as follows.

1) Apparent diseases of tunnel arch walls include cracking, falling blocks, cracking, and moisture accumulation in the tunnel lining.

Diseases such as lining corrosion and damage

2) The diseases of the tunnel arch wall structure include insufficient lining thickness, insufficient strength, non-dense lining cavities, lining corrosion, intrusion, and other diseases.

3) The main diseases at the bottom of the tunnel include cracking, non-compaction, water filling, sinking, mud pouring, and insufficient thickness of the tunnel bottom.

4) The diseases of the drainage system include broken blind pipes, water leakage, broken ditches, blockage and paralysis of the drainage system, and paralysis of the drainage system of the dewatering well.

5) The main diseases inside the car shelter include water leakage, deformation, peeling, and other diseases.

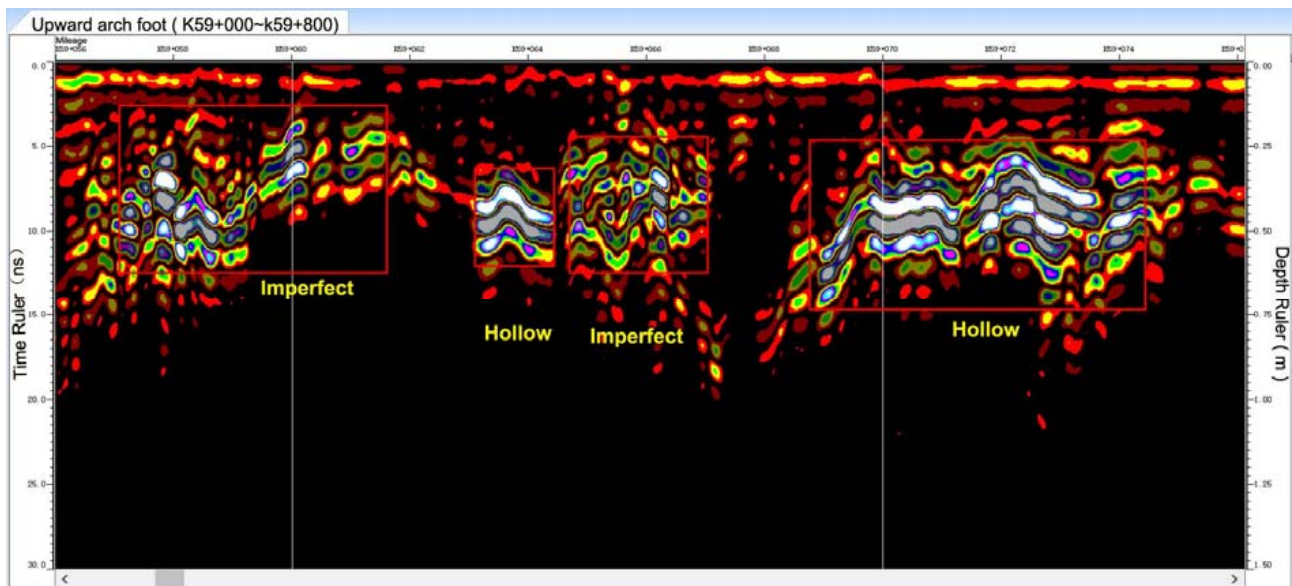

Fig. 10. Typical image of voids and non-compact areas inside (behind) the lining

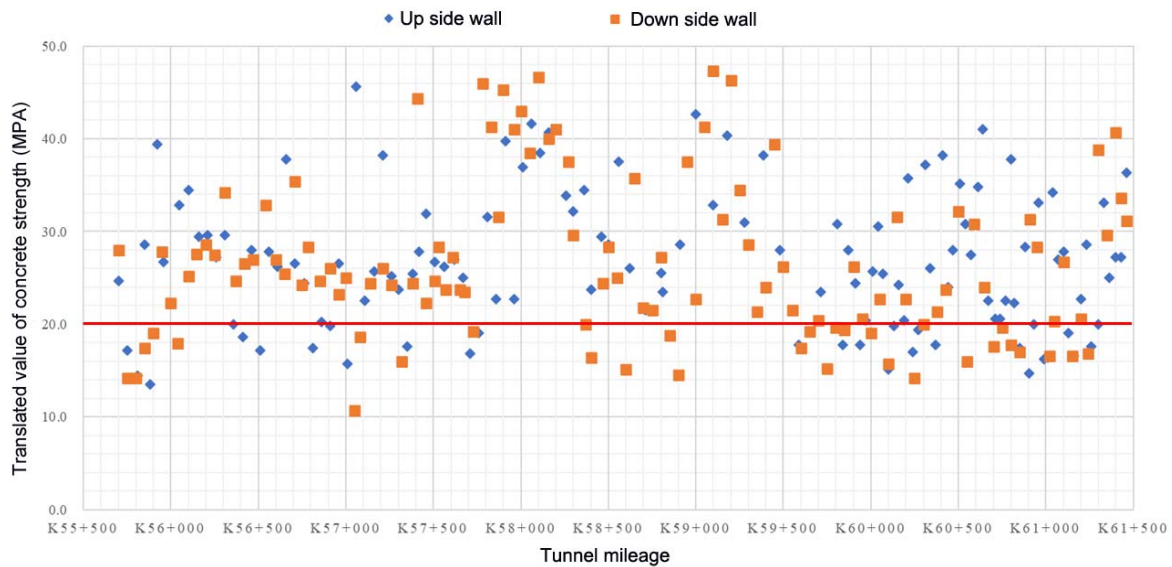

Fig. 11. Distribution of the concrete strength of existing tunnel lining side walls by mileage

6) Other diseases include a large number of missing stakes in the line, severe water accumulation in ventilation openings, and the proximity of other underground mining tunnels to the tunnels.

The results of all the diseases detected in this test are summarized in the table 2. For a detailed display, please refer to the "Comprehensive Disease Display Diagram of a Certain Tunnel".

#### *Comprehensive display diagram of tunnel diseases*

By integrating all the historical data and inspecting the disease data, a comprehensive disease display chart for a certain tunnel was drawn, aiming to fully display the current state and existing disease state of the tunnel. This map is based on the longitudinal section map measured this time, and three parts were collected: historical data statistics, detection results, and historical disease treatment statistics. The first part of the tunnel longitudinal section diagram collects information from the completion data, including the type of surrounding rock, lining section (design thickness, changes, and reference drawings), geological conditions (overall overview and coal seam statistics), geomorphology, steel support statistics, construction collapse statistics (construction length, collapse amount, maximum arch cavity height, and single linear meter collapse amount), ground elevation, inner rail top surface elevation, design slope, construction auxiliary tunnels, and ground changes. This section fully reflects the original structure of the tunnel. The second part shows the disease state identified by all the information tested in this test, including the distribution of arch wall diseases, tunnel bottom diseases, arch wall lining inspection thickness, tunnel bottom inspection thickness, and side-wall concrete

inspection strength, all of which are shown in the figure. In the longitudinal section, the positions of the gullies, factory buildings, and terrain change points detected in the comprehensive environment, as well as the auxiliary tunnels are shown. From the graph, all the detected diseases at any cross-section can be read. The third part is the layout diagram of previous disease rectification and reinforcement, from which we can see which reinforcement measures have been taken in these areas.

For example, the K56+830–57+000 mileage section is located below the third gully, and its developed small gully is consistent with the direction of the line here. During construction, this section experienced significant collapse, with a maximum collapse of 34.38 cubic meters per linear meter and a maximum void height of 3 m. There is also a ventilation shaft outside this site, which is well exposed and has a significant amount of internal water accumulation. The lining inside the tunnel has serious water leakage, and the lining surface has a large area of corrosion. The arch crown is cracked and falls seriously, and the concrete strength (17.4 MPa) is relatively low. The right arch waist is limited, and there are serious cavities and non-compact diseases behind the lining. The bottom plate of the tunnel is not compact, filled with water, and cracked severely, and there is serious mud pouring. There has been a history of arch crown anchor rod reinforcement. It is recommended to perform rectification as soon as possible.

The K60+790–K60+970 mileage section is located below the eighth gully. There are two longitudinal cracks that run through the arch waist, with many cracks, severe water leakage, and limited penetration. Other issues are the insufficient lining thickness and low concrete strength. The arch crown contains coal seams, voids, etc. The arch crown has

Table 2. Disease Detection Results

Number	Project	Unit	Nondestructive testing	Manual tapping and investigation	External environmental investigation	Remarks
1	Lining chipping	place		43		
2	Invasion limit	place	267			
3	Insufficient lining thickness	place	4942			
4	Insufficient concrete strength	place	60			
5	Cracks (0.3–0.5 mm)	place	151			
6	Cracks (>0.5 mm)	place	2752	37		Cracking of lining
7	Cracking	place	3			
8	Yin dampness	place	1698	91		Leakage water
9	Lining corrosion	place	3			
10	Damaged lining	place	284			
11	Interior panel	place	96			
12	Empty	place	1073	164		
13	Not dense	place	1046			
14	Bottom plate cracking	place	22			
15	Bottom of the tunnel is not dense enough	place	120			
16	Tunnel bottom is not compacted and filled with water	place	82			
17	Tunnel bottom churning and mud seepage	place		19		
18	Gully fracture	place		13		
19	Avoiding tunnel diseases	quantity		239		
20	Investigation of the water level in the side ditches	place		32		
21	Investigation of the water level in precipitation wells	quantity		64		
22	Gully	quantity			8	Outside the tunnel
23	Auxiliary tunnel	quantity			11	Outside the tunnel
24	Coal mine roadway	quantity			2	underground
Total		place	13301		21	

been reinforced with anchor rods. It is recommended to perform rectification as soon as possible.

*Evaluation of tunnel disease level*

The tunnel was graded in sections of 100 m, and all the sections were graded based on nondestructive testing results. The results of each section were rated as AA level, and combined with manual tapping and observation results, according to the Provisional Regulations on Safety Level Evaluation of Railway Operation Tunnel Lining, the safety level of the tunnel lining is extremely severe, i.e., AA level. The tunnel should be renovated as soon as possible and 24 h monitoring work be conducted to ensure driving safety.

*Verification and supplementation of digital collection results*

The above digital achievements in the rapid machine inspection of information technology were verified and supplemented through methods such

as manual tapping, numerical simulation, and comprehensive investigation and analysis.

(1) Tunnel manual tapping detection technology: The method of manually tapping the tunnel wall (Fig. 12) was used to investigate hidden dangers in the tunnel lining (Bao et al., 2023). The main factors to be investigated include concrete cracks, falling blocks, voids, water leakage, water accumulation in ditches, diseases in car shelters, and mud pouring from the tunnel. The main results are various disease tables, including data on voids and cracks, which are mutually verified with nondestructive testing results. A comparative analysis showed that the results of nondestructive testing and manual testing mostly overlap with each other, proving the high accuracy of the nondestructive testing data in this study.

(2) Numerical simulation: By comprehensively analyzing all the detection results, weak links and typical sections of tunnel structures and diseases



Fig. 12. Tunnel manual tapping detection

were identified, modeling was done with measured data, a numerical simulation analysis was conducted on the tunnel, the trend in the tunnel deterioration was identified, and preparations were made for later operation and maintenance of the tunnel. The MIDAS-GTS software was used in the numerical simulation calculation of this tunnel. Based on all the detection results, 76 typical cross-sections in areas with severe diseases were selected and subjected to 2D and 3D numerical simulations (Fig. 13) to determine the bearing capacity of the tunnel lining and the safety of the tunnel structure, and to analyze and predict the further deterioration trend of the tunnel. After using the load structure method to calculate and analyze the tunnel lining structure with different thicknesses and strengths, it was found that the safety factor at the intersection of the arch and the side walls on both sides did not meet the regulatory requirements in all 76 sections, and the safety factor at the arch crown, arch waist, and arch foot of some sections did not meet the requirements. The calculation results obtained using the geological structure method and the load structure method exhibited consistent trends.

(3) Comprehensive investigation and analysis method: By investigating the daily regular inspection

data in tunnel engineering, combined with historical data, tunnel interior surveys, nondestructive testing results of tunnel lining diseases, and manual testing results, special investigations and research were conducted on tunnel boundaries, water damage inside the tunnel, tunnel bottom diseases, and water quality. The intrusion limit inside the tunnel was mostly caused by historical reinforcement measures and the increase in the amount of ballast at the bottom of the tunnel. The water quality inside the tunnel was good and noncorrosive. Due to the poor geological conditions, unclear inverted arch structure, paralyzed drainage system, increased transportation volume, repeated action of heavy-duty trains, and untimely operation and maintenance, the tunnel bottom exhibited serious diseases.

**Conclusions**

(1) Basic working methods were established. By digitizing historical tunnel data and applying information collection technologies, such as drone aerial photography, ground penetrating radar, and full-section laser scanning, a basic database for the intelligent management and maintenance of existing operational tunnels was established.

(2) A comprehensive analysis method was established. Through methods, such as manual tapping, numerical simulation, and comprehensive investigation and analysis, the results of the information technology testing were reviewed, verified, and supplemented. The database established for the information technology testing results was found to be accurate and reliable.

(3) All the data were digitized and connected. By conducting comprehensive research and drawing a comprehensive disease display chart, all the data can be integrated and displayed for a comprehensive analysis.

(4) The 3D display software platform inside and outside the cave requires further improvement. Drone aerial photography technology was used to conduct a 3D modeling of the external environment of the tunnel, and the full-section laser scanning technology was applied to collect 3D data inside the tunnel. All the digital collection results can be

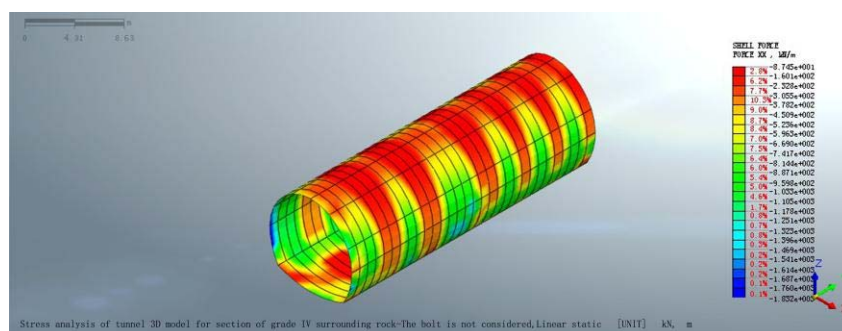

Fig. 13. Modeling results of the stress acting at typical sections of the tunnel lining



incorporated into the BIM platform to achieve a 3D integrated visualization display in the later stage. By studying the visualized 3D model, the causes of diseases can be identified and analyzed efficiently and intuitively.

(5) The next step is to strengthen research on rapid inspection equipment to better adapt to the rapid detection of various operating tunnels with heavy traffic.

(6) Regular inspections can be combined with targeted rapid inspections to improve the level of facility security. The tunnel can be combined with regular inspections and targeted rapid inspections during operation and maintenance. By comparing and analyzing multiple detection results from different periods, it is possible to quickly identify the causes and trends in the changes in the tunnel structure, providing assurance for later operation and maintenance.

## References

- Bao, X. Z., Da, Z. H., Zhang, C. B., Chai, X. S., Kang, Z. X., Zhou, Y., and Dai, X. J. (2023). Knocking Echo Characteristics of Tunnel Lining Cavity. *China Railway Science*, No 4, pp. 144–152.
- Cheng, F. Y., Yao, G. M., Kui, Y. C., Wang, J. H., and Zhao, X. Q. (2019). GIS/BIM-Integrated Digital Management of Highway Tunnel and Its Application. *Tunnel Construction*, Vol. 39, Issue 12, pp. 1973–1980. DOI: 10.3973/j.issn.2096-4498.2019.12.007.
- Dai, C. P. (2022). Life Cycle Management of Heavy Haul Railway Track Infrastructure Based on Digital Model. *Railway Engineering*, No 8, pp. 37–41.
- Gong, J. F., Wang, W., Li, X., and Zhu, Y. (2023). Statistics of Railway Tunnels in China by the End of 2022 and overview of key tunnels of project newly put into operation in 2022. *Tunnel Construction*, Vol. 43, Issue 4, pp. 721–736.
- Li, F., Chu, M. H., Dai, Q. H., and Zhang, L. P. (2005). Research on key technique of aerophotogrammetry flight management system based on GPS and GIS. *Science of Surveying and Mapping*, Issue 6, pp. 38–39.
- Shao, W. W., Cheng, Y., Li, H. Y., and Ma, W. G. (2023). Analysis and Remediation Methods of Tunnel Lining Defects Based on Geological Radar. *Journal of Engineering Geophysics*, No, 01, pp. 1–10.
- Sun, Y. M., Li, Y., and Nie, Z. G. (2020). Integration technology of 3D GIS and BIM and its application in highway tunnel intelligent management and maintenance system. *Bulletin of Surveying and Mapping*, Issue 10, pp. 127-130. DOI: 10.13474/j.cnki.11-2246.2020.0334.
- Tian, S. M., Wang, W., and Gong, J. F. (2021). Development and Prospect of Railway Tunnels in China (Including statistics of Railway Tunnels in china by the End of 2020). *Tunnel Construction*, Vol. 41, Issue 2, pp. 308–325. DOI: 10.3973/j.issn.2096-4498.2021.02.018.
- Wen, Z. B., Duan, Q., and Li, Z. Z. (2014). Application of laser holographic scanning technology in tunnel disease investigation. *Traffic Standard*, No 23, pp. 115–118.

# МЕТОД ПОСТРОЕНИЯ И ПРИМЕНЕНИЕ ОСНОВНОЙ ЦИФРОВОЙ БАЗЫ ДАННЫХ ДЛЯ ИНТЕЛЛЕКТУАЛЬНОГО УПРАВЛЕНИЯ И ОБСЛУЖИВАНИЯ СУЩЕСТВУЮЩИХ ЖЕЛЕЗНОДОРОЖНЫХ ТОННЕЛЕЙ

Хайинг Лв<sup>1,2\*</sup>, Леи Ванг<sup>3</sup>, Хуилин Янг<sup>1,2</sup>, Руиджи Сан<sup>1,2</sup>, Джин Янг<sup>4</sup>

<sup>1</sup>Научно-исследовательский центр технологий железнодорожных перевозок, Китайская компания строительства коммуникаций (СССС), Пекин, КНР

<sup>2</sup>Департамент технологий железнодорожных перевозок, Китайская компания строительства коммуникаций (СССС), Пекин, КНР

<sup>3</sup>Департамент перевозок, компаний Китай Шеньхуа Энерджи г. Юйлинь, КНР

<sup>4</sup>Китайский научно-исследовательский институт железнодорожных коммуникаций, Пекин, КНР

\*E-mail: 121910470@qq.com

## Аннотация

**Введение.** В Китае имеется обширная сеть туннелей, требующих обслуживания. Интеллектуальное управление и обслуживание этих туннелей на основе цифровой информационной системы может быть полезным. Для этого необходимо собирать соответствующую цифровую информацию о кожухе туннеля и окружающей среде для долгосрочного обслуживания. **Целью** было взять в качестве объекта исследования существующий действующий туннель. В данном исследовании применяются различные методы информационных технологий для построения основной цифровой базы данных для интеллектуального управления и обслуживания туннелей. **Используемые методы:** статистические данные, беспилотная аэрофотосъемка, данные малоглубинного радиолокационного зондирования, данные полнопрофильного лазерного сканирования и теоретический анализ. **Результаты.** База данных может быть использована в качестве справочного пособия для аналогичных проектов.

**Ключевые слова:** интеллектуальное управление и обслуживание; цифровизация; основная база данных; аэрофотосъемка; полнопрофильное лазерное сканирование; малоглубинное радиолокационное зондирование.

# METHOD TO IMPROVE THE EFFICIENCY OF VOLUMETRIC HYDROPHOBISATION OF PROTECTIVE LAYERS OF BUILDING STRUCTURES

Valeria Strokova<sup>1</sup>, Christina Urmanova<sup>1</sup>, Georgiy Kalatozi<sup>1</sup>, Sofya Nerovnaya<sup>1\*</sup>, Lyubov' Shakhova<sup>2</sup>

<sup>1</sup>Belgorod State Technological University named after V.G. Shukhov, Belgorod, Russia

<sup>2</sup>Vladivostok Research Center for Construction Materials, LLC, Spassk-Dalny, Russia

\*Corresponding author's email: nerovnaya.sofya@yandex.ru

## Abstract

**Introduction.** The protection and repair of concrete structures are the challenges of high priority, some solutions of which are presented in standards such as EN 1504 and GOST 32016–2012. Application of waterproof compounds is one of the main methods to protect concrete structures from water impact. Sealants are widely used to preserve the concrete properties, providing surface or volumetric hydrophobization. **Purpose** of the study was to develop and substantiate a new method to improve the efficiency of volumetric hydrophobization of protective layers made of dry mix mortar (DMM) based on microcement. **Materials and Methods.** Microcement MC MicroOST brand produced by New Technologies LLC was used as the main component of dry mixes, aluminous (AC-35-40) and high aluminous (HAC-70) cements were considered as aluminate components. Comparative assessment of hydrophobic properties of the prepared formulations of DMM based on microcement was carried out by contact angle and water absorption indicators. **Results** of the study showed that samples with introduction of aluminate component, such as high alumina cement (HAC), demonstrated high level of hydrophobicity and faster completion of water uptake into the material, relative to samples with HAC-35-40, samples of control formulation K-1, or with alternative additives (formulation with Mapelastik). It was found that introduction of high alumina cement in amount of 10–15 % provides maximum hydrophobicity for the proposed method. Analysis of the form of the water contact angle revealed formation of water-repellent film on the treated surface of samples with 10 and 15 % of high alumina cement. With regard to other coatings, it has been noted that they are highly resistant to water penetration deep into the material. These results demonstrate high efficiency of the proposed method to improve volumetric hydrophobization of protective layers made of dry mix mortar and used to protect building structures from moisture and ensure their durability and strength.

**Keywords:** dry mix mortarres, hydrophobicity, aluminate component, contact angle, water absorption, protective layer, repair compounds.

## Introduction

Modern world experience of urban development in big cities shows that optimal conditions for sustainable development and comfortable living in the city may be reached if the share of underground structures in the total number of constructed facilities is not less than 20–25 % (Popov and Demidova, 2013). Meanwhile, concrete is the most frequently used material for the construction of underground buildings and structures. It is classified as a capillary porous material and is therefore characterized by its ability to absorb and filter the water. Porosity under otherwise equal conditions depends on the quality of concrete mix laying, selected materials, and decrease in the performance characteristics of concrete over time is determined by operation of the structure in severe hydrogeological conditions. In this regard, in recent years, much attention was paid to the protection and repair of concrete and reinforced concrete structures.

The EN 1504 standard adopted in Europe in 2009 regulates requirements for materials and systems for protection and repair of concrete structures.

The Russian Federation in 2012 developed GOST 32016 standard aimed at harmonization with the above mentioned EU standard, the GOST standard sets out the principles and methods of protection and repair of concrete structures.

According to the requirements of regulatory documentation, the most available methods of protection of concrete structures from corrosion, excessive water absorption, and reduction of thermal protection properties are coatings with waterproof formulations (Kubal, 2012; Zarubina, 2011).

Special hydrophobic formulations, which can provide surface or volumetric hydrophobization according to the method of water impact protection (Fig. 1) are used for preservation of properties of concrete in structures.

It shall be noted that during surface hydrophobization the Formulations of Group 1 (Table 1) provide water resistance due to dense compaction of low permeability microstructure with polymer film, which provides water-resisting properties inside the matrix. The formulations

of Group II increase water resistance by hydrophobization of the surface of capillaries, which blocks the penetration of water into cement structure.

According to this property, waterproof materials are classified as:

- materials preventing filtration of water under pressure;
- materials which do not absorb water by capillary water absorption when the surface of the product comes into contact with water.

Despite the availability of a wide range of various waterproofing materials, reliable results may be achieved only due to the correct choice of components, their compatibility and strict compliance with the Standard Operating Procedures. Moreover it is well known that hydrophobicity is determined not so much by properties of the material as a whole, but rather by the properties and structure of the near-surface layer, which is several micrometres thick (Boinovich and Emelyanenko, 2008). The design of hydrophobic coatings was guided by the principles of creation of such formulations, based on the latest achievements in the field of design of waterproof protective films (Zhao et. al., 2006; Selyaev et. al., 2019; Martuzaev et. al., 2021; Hao, 2021; Jihui et. al., 2022).

Beside high hydrophobicity, protective coatings should have high adhesion to the original concrete and the maximum compatibility with its structure. A popular method is the introduction of waterproofing additives directly into the cement-sand mixture. However, such cement-sand formulations are subject to shrinkage phenomena, which reduces the protective properties of the coatings. Therefore, in practice, waterproofing coatings based on a formulation of Portland cement and gypsum alumina cement, which provides the effect of shrinkage reduction or even slight

expansion are widely used (Chumachenko et. al., 2016; Liang et. al., 2023; Maltseva, 2016; Lesovik et. al., 2014). According to research studies, the dosage of alumina-containing components used for the improvement of the waterproofing ability of the formulation of multipurpose dry mixtures varies from 1.5 to 50 % (Kuzmina, 2017). This is due to the fact that, hydration products of alumina cement in the formulation with Portland cement recrystallize over time from hexagonal calcium hydro aluminates into cubic hexahydrates of tricalcium aluminate, which leads to decrease in strength of products (Kalatozi et al., 2024). To prevent this transition, modifying additives that increase stability of hydrate neoplasms are introduced into the dry mix formulation. The effect of hydrate phases of alumina cement expansion allows to increase density of the matrix and thereby increase the degree of protection of concrete structures from water penetration.

Regulation of properties of such formulations is possible by application of various modifying additives, which not only determine the setting time and kinetics of the strength gain, but also provide the effect of waterproofing due to the impact on formation of hydrate phases with dense compaction of matrix and formation of a surface with low surface energy at the solid/liquid boundary.

It is possible to increase hydrophobicity of the surface by creation of special texture on the material surface with the application of fillers with multimodal particle size distribution embedded in the matrix of hydrophobic material, due to which a "lotus effect" is created on bumpy surface, when a drop of water cannot be evenly located on it, because it is prevented by surface tension forces (Pang et. al., 2023).

In the process of consideration of the principles and methods of protection, special attention should be paid to compatibility of applied materials for repair

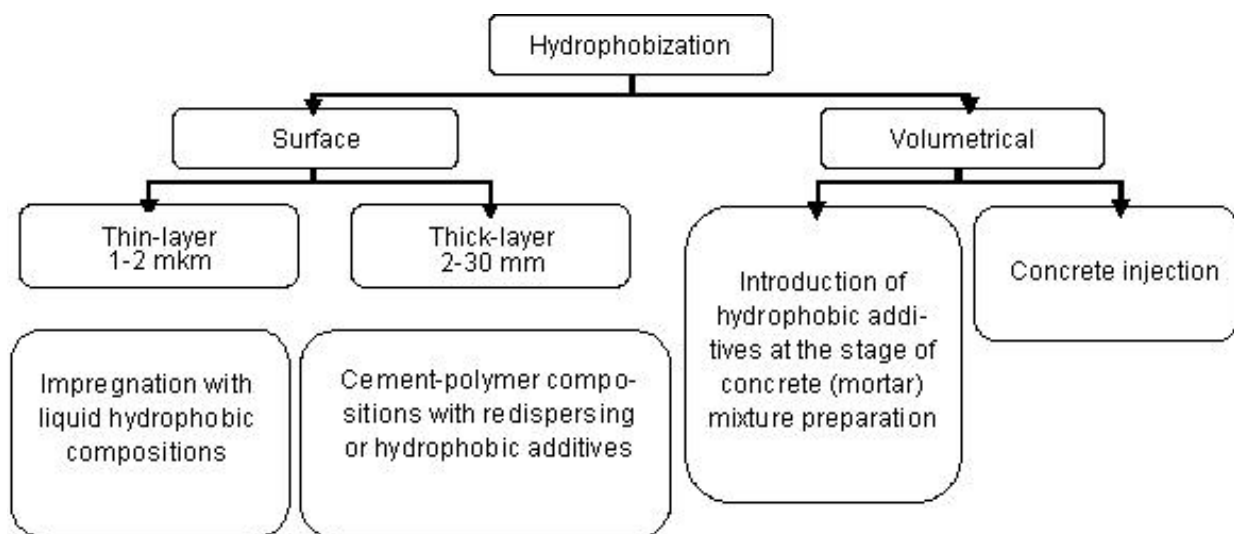

Fig. 1. Methods of concrete and reinforced concrete structures protection with the use of hydrophobic special formulations

Table 1. **Methods and Mechanisms Providing Water Resistance of Protective Coatings**

Formulation types	Waterproofing method	Waterproofing mechanisms	
Group I	Coatings preventing filtration of water under pressure	After hardening the coatings form microporous structures with low permeability (filtration coefficient $K_f \leq 1 \cdot 10^{-10}$ ), withstanding water pressure up to 0.8–1.0 MPa and more (according to GOST 12730.5).	The coatings provide dense compaction of mineral components of the cement mix, as well as aggregate and filler particles due to the application of different functional additives that create a cement-polymer film with low microporous structure.
Group II	Coatings which do not absorb water by capillary water absorption when the surface comes into contact with water	Due to the effect of capillary surfaces hydrophobization, they form coatings that are not wetted by water and have water absorption approaching zero.	The coatings do not protect structures from penetration of pressurized water, but reduce the rate of its filtration through the coatings. These materials prevent moistening of fencing elements of the structure when they are exposed to heavy rainfall, in conditions of possible capillary rise of groundwater, when condensate is formed on the surface of structures due to the introduction of water-repelling agents into the mixtures.

and protection works with original concrete of the structure (Sokolova, 2010). Cement-based dry mix mortar that provide hydrophobic protective coatings are suitable for protection of concrete and stone surfaces from moisture, as well as brick and ceramic facades of buildings, paving slabs, swimming pools and terraces. The surface treatment with such formulations leads to formation of hydrophobic coating with low porosity, which reduces water absorption of the material and increases its service life (Abdalla et al., 2009; Malgorzata et al., 2023; Loganina et al., 2013).

During production of dry mix mortars, joint grinding of Portland cement and functional additives provides homogeneity of mineral formulation of the product and its physical and mechanical properties, leads to simultaneous mechanical activation of all components, provides special properties by introduction of functional additives in the grinding process and guarantees high compatibility of microcement matrix and concrete structures (Shakhova et al., 2023).

Particle size of the formulation and uniform distribution of all components are of particular importance. Therefore the microcement was used during preparation of effective waterproofing coatings. Size of microcement particles is comparable with the size of capillaries and may penetrate deep into the body of concrete in the form of dilute aqueous suspensions, blocking water flows, as well as restoring the strength lost over time. The second component used was finely ground sand with an average particle size of less than 25  $\mu\text{m}$ .

In this regard, the purpose of the study was to prepare and substantiate the method of improvement of the efficiency of volumetric hydrophobization through introduction of alum-containing components into dry mix mortars based on microcement and

determination of optimal ratio of these components, providing maximum contact angle, and minimum water absorption.

#### Methods

This study refers to investigation of the surface and hydrophysical properties of the prepared formulations of dry mix mortars based on microcement. The following components were used for the study: microcement of MC MicroOST brand produced by the New Technologies LLC (Shakhova et al., 2023); alumina (AC-35 40) and high alumina (HAC-70) cement produced by the Pashinsky Metallurgical and Cement Plant OJSC; gypsum produced by the Peshelansky Gypsum Plant LLC.

Quartz powder obtained by grinding of quartz sand produced by the New Technologies LLC (hereinafter — ground sand) was used as a filler.

Typical particle sizes and Blaine specific surface area of microcement and ground sand in the formulation are presented in Table 2.

To improve special properties to dry mixtures, a complex modifying additive consisting of setting regulators, dispersants and acrylic copolymers was additionally introduced.

To obtain a thin-layer coating formulation from the dry mix, mixing water was added until equal mobility was reached, which was evaluated by Kantro's slump test (Kantro, 1980).

Hydrophobic protective compounds were applied by brush to pre-cleaned surface of mortar samples with dimensions 40×40×160 mm (shape according to GOST 30744–2001) in 2 layers. Before application of the waterproofing layer, the surface of the samples was wetted. Thickness of the protective coating was 1–1.5 mm. Samples with a protective layer were stored in a normal hardening chamber at a temperature of (20±3) °C and relative humidity of (95±5) % during 28 days.

Samples of uncoated cement-sand mortar (K-1) and samples coated with Mapelastic, a 2-component mixture widely used for waterproofing concrete pavements, produced by Mapei, were taken as control samples to compare the hydrophobic properties of the prepared formulations.

The waterproofing coating was evaluated by two methods. Water absorption of samples was tested according to GOST 12730.3–2020. After 28 days of hardening, the coated samples were weighed and then immersed in water so that the water level was 50 mm above the top level of the samples. After every 24 h, the samples were removed from water and pre-wiped with a drained damp cloth. Test was carried out until the results of two consecutive weighings differed by not more than 0.1 %.

The second method was the well-known water droplet test, which was performed by optical measurement of the contact angle of the surface by a droplet (Iwamatsu, 2011; Mittal, 2018; Bormashenko., 2009; Antonini et. al., 2009). The contact angle of liquid on the surface of a porous capillary body may be formed only in presence of a film that prevents movement of liquid into the material under study.

It does not take into account the effect of water pressure on moisture penetration into the sample (Loganina and Sergeeva, 2020). During complete wetting of the surface the angle is 0 degrees, and during complete non-wetting the angle is 180 degrees, this is the main factor for determination of the hydrophobicity or hydrophilicity of material. The contact angle was measured with Kruss DSA 30 instrument. For this purpose, a drop of water was applied to the sample with protective coating, the fact of drop application was pictured. The treatment was carried out according to the instrument program.

Type and dosage of alumina cement, as well as content of ground sand varied in the dry mix formulations based on microcement (Table 3). We

studied formulations with alumina cement content from 5 to 15 wt. %.

During calculation of the composite content based on hydrophobic cement formulations, we initially determined requirements for the final product, such as degree of hydrophobicity, strength, environmental resistance and other technical parameters. Then, we selected components including wetting agents, strength boosters, stabilizers and other auxiliary additives in order to provide the required properties. Next, we conducted laboratory studies and tests to determine the rational concentrations of components and their interactions, providing the desired technical characteristics and product quality (Selyaev et al., 2019; Badmaeva et al., 2022; Guvalov et al., 2018; Nguyen et al., 2023).

Thus, the following formulations were analyzed in this paper:

1. Samples of prepared DMM labeled GF-5, GF-10, and GF-15. Composite binder (microcement + alumina cement + gypsum) + ground sand + complex additive. Microcement was used to improve performance characteristics of the composite. The purpose of its application is to get a denser and stronger surface, which contributes to the durability and aesthetic appearance of the product. Alumina cement was added to improve chemical resistance and strength of the composite. This type of cement has a high degree of resistance to aggressive chemicals and provides additional protection against degradation processes. In addition, a complex additive was used to regulate the time of the composite hardening, increase mobility of the mixture and provide hydrophobic effect. This additive enables precise monitoring of the time required for the composite to harden, which is particularly important in handling. Increasing mobility of the mixture makes the application easy and convenient, and the hydrophobic effect helps to

Table 2: Typical Particle Sizes and Specific Surface Area

Characteristics	Microcement MC MicroOst	Ground sand
Particle diameter at 95 wt%; D <sub>95</sub>	16	65
Modal particle diameter, wt %; D <sub>cp</sub>	7.5	15.7
Blaine specific surface area, m <sup>2</sup> /kg	950	610

Table 3. Formulations of dry mix mortars

Formulation identification number	Composite binder, %				Ground sand, %	Complex modifying additive, %	w/c ratio
	MC	HAC-70	AC-35 40	Gypsum			
GF-5	40	–	5	1.65	53.1	0.25	0.25
GF-10	40	–	10	1.65	48.1	0.25	0.22
GF-15	40	–	15	1.65	43.1	0.25	0.24
GA-5	40	5	–	1.65	53.1	0.25	0.27
GA-10	40	10	–	1.65	48.1	0.25	0.265
GA-15	40	15	–	1.65	43.1	0.25	0.26

protect the structure from moisture and improve its resistance to external factors.

2. Samples of prepared DMM labeled GA-5, GA-10, and GA-15. Composite binder (microcement + alumina cement + gypsum) + ground sand + complex additive. High alumina cement was used to improve strength and resistance of the composite to aggressive impact. This type of cement is characterized by high alumina content, which provides it with exceptional resistance to chemical attack and abrasion. Addition of high alumina cement to the composite allows for creation of material that can withstand extreme operating conditions such as high temperatures, humidity, aggressive chemical environments and mechanical stresses. Advantages of the application of high alumina cement include its ability to form crystalline structures that have high strength and corrosion resistance. This contributes to significant extension of the service life of structures made of such composite and reduction of the risk of their destruction under impact of various factors.

3. Sample of uncoated cement-sand mortar (K-1) — as a reference mortar.

4. Sample coated with Mapelastic, a two-component mortar based on cement binder, fractionated fine aggregate, special additives and synthetic water-dispersion polymers mixed according to a formula originated by Mapei's own research laboratories.

## Results and discussion

According to the test results of coatings shown in Figs. 2–4, it was found that the samples the surface of which is coated with formulations GA-10 and GA-15, which corresponds to contact angle values of  $100^\circ$  and  $96^\circ$ , respectively, have a hydrophobic effect. The formulations of such coatings include high alumina cement HAC-70, content of which is 10 % and 15 %, respectively. This means that formulations have the ability to repel water, which makes the surface of the material less susceptible to moisture penetration. As for other coatings, their high resistivity to water penetration deep into the material was observed. These coatings act as a barrier to water penetration into the matrix, preventing its destruction and preserving its structure and strength over time. Therefore, the results demonstrate effectiveness of GA-10 and GA-15 formulations with high alumina cement as hydrophobic coatings to protect materials from water and improve their performance properties. The lowest contact angle was measured in the formulation from Mapelastic (18).

The overall ranking of the samples according to contact angle increase is as follows:

K-1 → Mapelastic → GA-5 → GA-15 → GF-5 →  
 → GF-10 → GA-15 → GA-10.

So, the introduction of high alumina cement from 10 to 15 % into the formulation allows reduction of surface energy at the solid/liquid interface.

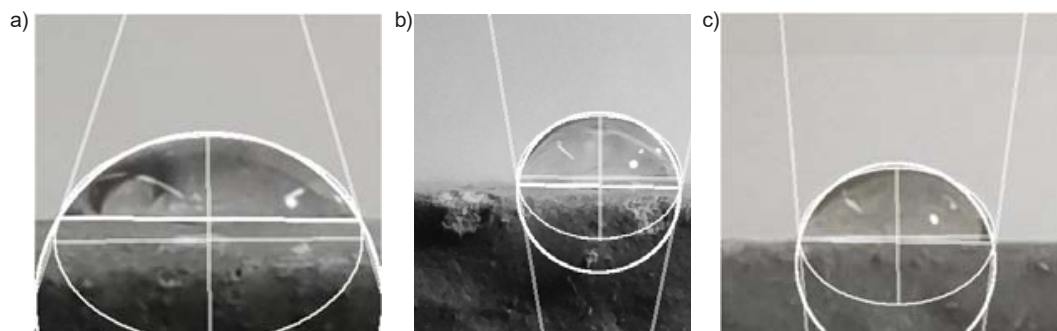

Fig. 2. Contact angle on the surface of the protective layer of the formulation containing AC-35-40:  
 a — GF-5 ( $\theta = 76^\circ$ ); b — GF-10 ( $\theta = 77^\circ$ ); c — GF-15 ( $\theta = 75^\circ$ )

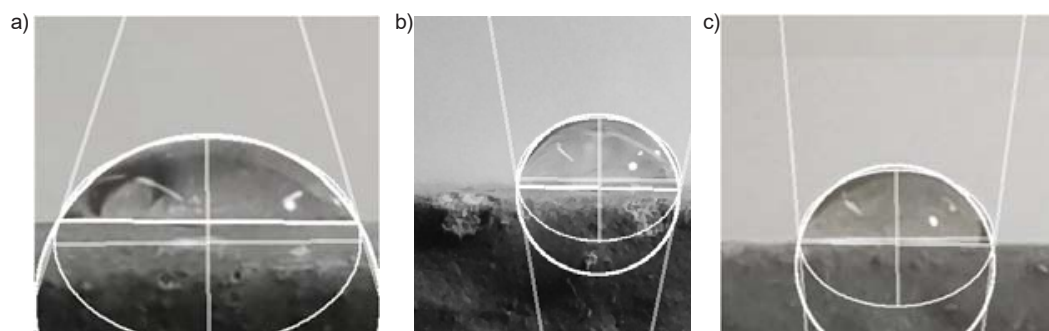

Fig. 3. Contact angle on the surface of the protective layer of the formulation containing HAC-70:  
 a — GA-5 ( $\theta = 74^\circ$ ); b — GA-10 ( $\theta = 100^\circ$ ); c — GA-15 ( $\theta = 96^\circ$ )

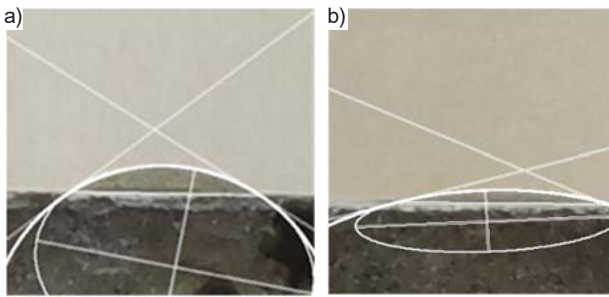

Fig. 4. Contact angle on the surface of the protective layer of the formulation: a — Mapelastik ( $\theta = 34.2^\circ$ ); b — K-1 ( $\theta = 18.3^\circ$ )

An additional criterion contributing to the assessment of the level of hydrophobization of surface coatings is the water absorption. Protective layer shall have hydrophobic properties and a dense volumetric structure to prevent water penetration to the concrete or mortar substrate. Kinetics of water absorption by samples coated with protective layers of hydrophobic dry mixes is presented in Fig. 5.

Analysis of the graphs showed that all samples have high water absorption during the first 3 days of the experiment. This period is characterized by intensive penetration of water into the material, which is due to its structure and surface characteristics. Approximately by Day 7 (for samples with HAC-70) and by Day 11 (for samples with AC-35-40) a stabilization of the water absorption process was observed. This is manifested in the fact that the sample mass change ceases to exceed 0.1 %, which proves the completion of the process of water penetration into the material.

It should be noted that in the reference sample K-1, completion of the water absorption process occurred on Day 10, and in the sample with Mapelastik coating — on Day 15. This points to different speed and efficiency of material protection from moisture penetration depending on the type and formulation of the coating used.

Therefore, experimental results allow us to conclude about the kinetics of water absorption of samples and effectiveness of hydrophobic coatings for protection of materials from water.

Analysis of water absorption by samples with coatings made of prepared dry mix mortars revealed the following trends. Compared to the coatings made of hydrophobic DMM Mapelastik, all samples with coatings showed better water absorption kinetics. The samples containing aluminate cement AC-35-40 showed faster completion of water uptake by four days compared to Mapelastik. The samples with introduction of HAC-70 aluminate cement showed even higher performance, completing the water uptake process eight days earlier than Mapelastik. Compared to the reference sample K-1, water absorption process was completed faster only for

samples containing HAC-70 aluminate cement, and this was achieved three days earlier.

So, the highest water absorption was observed in the reference formulation K-1 (10 %). Protective coatings may reduce water absorption to 5 % on Mapelastik and up to 4 % on all prepared formulations.

Compared to the sample coated with Mapelastik formulation, application of coatings of the formulation series GF-10 and GF-15 can reduce water absorption by 2.5–3 times (from 150 % to 200 %).

During introduction of aluminate cement HAC-70 (series GA-10 and GA-15) into the formulation of protective coating, the water absorption decreased 2.8–4 times (from 180 % to 280 %).

High water absorption was observed in formulations GA-5 and GF-5. It means that despite the fact that the contact angles for a series of GF formulations are approximately equal, with the content of alumina cement 5 %, it was not possible to obtain dense layer of protective coating.

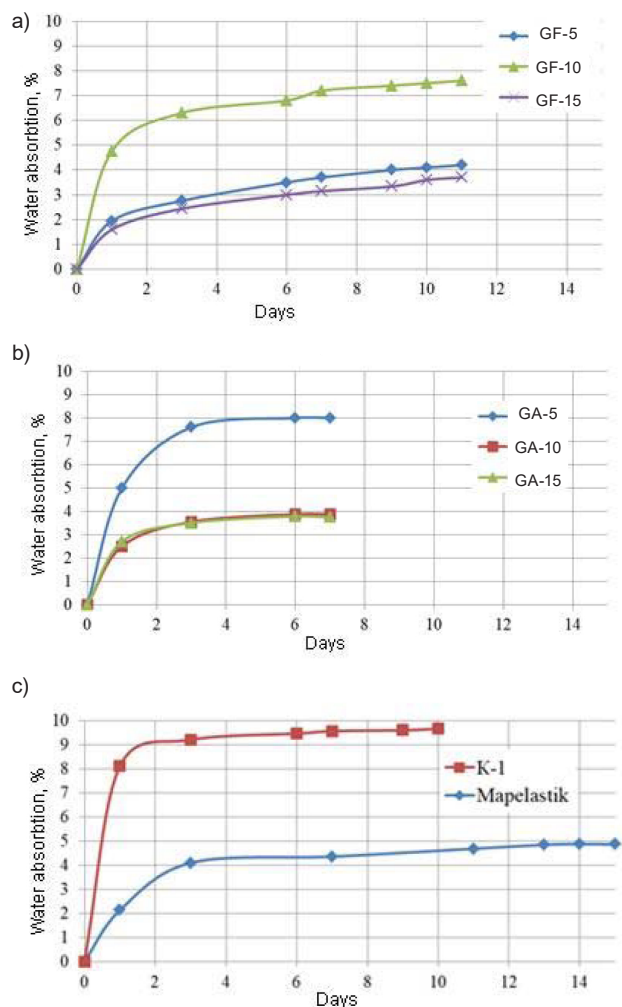

Fig. 5. Water absorption of cement-sand mortar samples with protective coatings depending on the formulation of dry mix: a — with the content of AC-35-40; b — with the content of HAC-70; c — control formulations Mapelastik and K-1.



The following trend of water absorption values growth relative to control samples (at 7 days) was established:

GF-15 → GA-15 → GF-10 → GA-10 →  
→ Mapelastik → GF-15 → GA-5 → K-1.

The most effective value of the amount of absorbed water at the end of water penetration into material, among the samples containing aluminate cement AC-35-40, was shown by the formulation with GF-15 — (3.7 %) (on day 11). Among samples containing high alumina cement HAC-70, the most effective was the formulation with GA-15 — (3.74 %) (on Day 7). These samples are distinguished by their high performance over the long run due to their resistive capabilities, which means that they are able to maintain stable characteristics under prolonged exposure to moisture.

So, the obtained results emphasize the importance of selection of the right DMM formulation to achieve optimal moisture protection and ensure long-term stability of the material under different operating conditions. This supports the high efficiency of the proposed method of improvement of efficiency of volumetric hydrophobization of protective layers made of dry mix mortars and used to protect building structures from moisture and ensure their durability and strength. It should be noted as well that the obtained formulations have a high resistive ability to water penetration, so they play a role of a barrier for concrete building structures.

The following conclusions can be drawn from the conducted studies on selection of formulation of waterproofing coatings for concrete structures:

1. The highest contact angle was observed in formulations of protective coatings GA-10 and GA-15, the smallest contact angle in the Mapelastik formulation. The other tested formulations have a contact angle of about 75–76°.

2. Ability to reduce water absorption in the tested formulations GA-10, GA-15 and GF-10 and GF-15 are approximately equal (4 %), which is slightly higher than that of Mapelastik (5 %).

3. GA-5 and GF-5 formulations failed to produce a protective coating with low water absorption capacity.

4. The type of alumina cement and critical dosages were determined, at the introduction of which it was possible to obtain formulations with high resistivity to water:

- formulations containing alumina cement AC-35-40 in all dosages and formulation containing 5 % HAC during measurement of the contact angle;

- formulation containing 15 % of alumina cement AC-35-40 and formulations containing 10 and 15 % HAC during measurement of the water absorption index.

### Conclusion

We have proposed and substantiated the introduction of aluminate components represented by alumina or high alumina cement into the formulations of dry mix mortars based on microcement in order to increase the efficiency of volumetric hydrophobization of protective coatings of concrete structures. The effectiveness of the originated approach was assessed by two methods: measurement of the contact angle and measurement of water absorption.

The study showed that introduction of aluminate cement into the formulation of dry mix mortars significantly improves their hydrophobic properties. Samples with addition of aluminate component — high alumina cement (HAC) showed a higher level of hydrophobization compared to samples without this component (reference formulation K-1) or with alternative additives (formulation with Mapelastik). Dosage of high alumina cement 10 % and 15 % is reasonable from the point of hydrophobicity increase.

BM containing aluminous cement as an aluminate component (AC-35-40) showed improved resistance to water absorption and faster completion of water absorption into the material, relative to samples with HAC, without this component (K-1) or with alternative additives (Mapelastik).

In water absorption studies, the most effective formulations were GA-10, GA-15 and GF-15.

Analysis of contact angle measurement showed availability of a water-repellent film on the treated surface of samples labeled GA-10 and GA-15 (samples containing HAC-70).

The obtained experimental data demonstrate the effectiveness of the proposed method of improvement of the volumetric hydrophobization, as well as the reasonable need for assessment of the quality of protective formulations by two methods aimed at assessment of the hydrophobic properties: measurement of contact angle and determination of water absorption.

### Funding

The research is carried out within the framework of the implementation of the state task of the Ministry of Science and Higher Education of the Russian Federation No. FZWN-2023-0006 using equipment of High Technology Center at BSTU named after V. G. Shukhov, Russia.

## References

- Abdalla, J. A., Thomas, B. S., Hawileh, R. A., and Kabeer, K. I. S. A. (2022). Influence of nanomaterials on the water absorption and chloride penetration of cement-based concrete. *Materials Today: Proceedings*, No 65, pp. 2066–2069. DOI: 10.1016/j.matpr.2022.06.427.
- Antonini, C., Carmona, F. J., Pierce, E., Marengo, M., and Amirfazli, A. (2009). General Methodology for evaluating the adhesion force of drops and bubbles on solid surfaces. *Langmuir*. Vol. 25, Issue 11, pp. 6143–6154. DOI: 10.1021/la804099z.
- Badmaeva, E. V., Lkhasaranov, S. A., and Urkhanova L. A. (2022). Dry building mixtures for floor coverings using nanodispersed additives. *Stroitel'nye Materialy (Construction Materials)*, No 1–2, pp. 76–81. DOI: 10.31659/0585-430X-2022-799-1-2-76-81.
- Bormashenko, E. (2009). Wetting of flat and rough curved surfaces. *Journal of Physical Chemistry C*, Vol. 113, Issue 40, pp. 17275–17584. DOI: 10.1021/jp905237v.
- Boynovich, L. B. and Emelianenko, A. M. (2008). Hydrophobic materials and coatings: principles of creation, properties and application. *Russian Chemical Reviews*, Vol. 77, Issue 7, pp. 619–638.
- Chumachenko, N. G., Dergunov, S. A., and Orekhov, S. A. (2016). Energy Efficient Compositions of Dry Concrete Mixes Based on Gypsum-Bearing Systems. *Procedia Engineering*, No. 150, pp. 1591–1599. DOI: 10.1016/j.proeng.2016.07.131.
- Guvalov, A. A, Kuznetsova, T. V., and Abbasova, S. I. (2018). Improving the efficiency of cement binders with the use of silica-containing modifier. *Stroitel'nye Materialy (Construction Materials)*, No 11, pp. 56–59. DOI: 10.31659/0585-430X-2018-765-11-56-59.
- Hao, Y., Zonglin, X., Chuhan, H., Yuan, Q., and Zhiwu, Yu. (2021). Recent progress of hydrophobic cement-based materials: Preparation, characterization and properties. *Construction and Building Materials*, No 299, pp. 124255. DOI: 10.1016/j.conbuildmat.2021.124255.
- Iwamatsu, M. (2011). Advances in Contact Angle, Wettability and Adhesion. *The Journal of Chemical Physics*, Vol. 134, Issue 23. DOI: 10.1063/1.3599710.
- Jihui, Z., Xuan, G, Siying, Ch., Houquan, L., Zhihao, L., and Xiaojie, L. (2022). Hydrophobic or superhydrophobic modification of cement-based materials: A systematic review. *Composites Part B: Engineering*, No 243, pp. 110104. DOI: 10.1016/j.compositesb.2022.110104.
- Kantro, D. L. (1980). Influence of Water-Reducing Admixtures of Properties of Cement Paste. A Miniature Slump Test. *Cement, Concrete and Aggregates*, No 2, pp. 95–102.
- Kalatozi, G.M., Urmanova, H.V., Netsvet, D.D., Shakhova, L.D., and Strokova, V.V. (2024). Mineralogical composition of hydration products of aluminates cements. *Regional Architecture and Engineering*, Vol. 58, Issue 1, pp. 40–46. DOI: 10.54734/20722958\_2024\_1\_40.
- Kubal, M. T. (2012). Builder's Handbook. Waterproofing of Buildings and Structures: Technologies, Materials, Operation. trans. from English. edited by S. A. Gladkov. Moscow: Tekhnosfera. p. 598.
- Kuzmina, V. P. (2017). Fillers for dry building mixtures. *Dry construction mixtures*, No 3, pp. 8–15.
- Lesovik, V. S., Zagorodnyuk, L. H., Shamshurov, A. V., and Belikov, D. A. (2014). Composite binder based on a complex organomineral modifier for dry repair mixtures. *The Bulletin of BSTU named after V.G. Shukhov*, No 5, pp. 25–31.
- Liang, Ch., Zhao, P., Liu, L., Wang, Sh., Wang, Sh., Sobolev, K., and Lingchao Lu. (2023). Fabrication of bulk hydrophobic cement-based materials with ultra-high impermeability. *Journal of Building Engineering*, No 63, pp.105492. DOI: 10.1016/j.job.2022.105492.
- Loganina, V. I. and Akzhigitova, E. R. (2013) Evaluation of hydrophysical properties of coatings based on dry construction mixtures using mineral and organomineral additives. *Regional Architecture and Engineering*, No 2, pp. 20–25.
- Loganina, V. I. and Sergeeva, K. A. (2020). Assessment of superhydrophobic properties of coatings on acrylic resin basis. *Regional Architecture and Engineering*, Vol. 42, Issue 1, pp. 98–103.
- Malgorzata, Sz., Zbigniew, O., Danuta, B.-H. (2023). Water absorption prediction of nano polymer hydrophobized concrete surface using texture analysis and machine learning algorithms. *Construction and Building Materials*, No 375, pp. 130969. DOI: 10.1016/j.conbuildmat.2023.130969.
- Maltseva, I. V. (2016). The dry waterproofing mix. *Engineering journal of Don*, Vol. 43, Issue 4, pp. 146.
- Mittal, K. L. (2018). Advances in Contact Angle, Wettability and Adhesion. *Scrivener Publishing*, Vol. 3. USA: Scrivener Publishing LLC. DOI: 10.1002/9781119459996.
- Murtazaev, S. A. Yu., Salamanova, M. Sh., Saidumov, M. S., and Ismailova, Z. Kh.(2021). Recipes for modified dry mixtures. *Herald of GSTOU. Technical Sciences*, Vol. 25, Issue 3, pp. 58–64. DOI: 10.34708/GSTOU.2021.52.18.009.

- Nguyen, D. T. L., Shvetsova, V. A., and Samchenko, S. V. (2023). Influence of complex additives based on alumina cement and trepel on the properties of portland cement. *Stroitel'nye Materialy (Construction Materials)*, No 4, pp. 65–72. DOI: 10.31659/0585-430X-2023-812-4-65-72.
- Pang, Y., Tang, Q., Yang, L., Wang, Q., Li, H., Lv, W., and Wang, R. (2023.) Development of a hydrophobic cement mortar with controllable strength: Preparation and micro-mechanism analysis. *Construction and Building Materials*, No 403, pp. 133216. DOI: 10.1016/j.conbuildmat.2023.133216.
- Popov, A. and Demidova, E. (2013). Time as a factor of architectural and spatial formation of the citybuilding. *Akademicheskij vestnik URALNIIPROEKT RAASN*, No 2, pp. 7–10.
- Selyaev, V. P., Nurlybaev, R. E., Kupriyashkina, L. I., Orynbekov, Ye. S., Kuldeyev, Ye. I., and Liyaskin, O. V. (2019). Multi-component system of dry construction mixtures. *News of higher educational institutions. Construction*, Vol. 724, Issue 4, pp. 20–27.
- Shakhova, L. D., Kharchenko, I. Ya., Strokova, V. V., Netsvet, D. D., and Kalatosi, G. M. (2023). Extra fine binders (microcements) and their use in construction. *Cement and its Applications*, No 2, pp. 30–36.
- Sokova, S. D. (2010). Choice of waterproofing materials for repair taking into account their compatibility and features of operation. *Vestnik MGSU*, No 4–5, pp. 151–156.
- Zarubina, L. (2011) Waterproofing of structures, buildings and constructions. St. Petersburg: BHV-Petersburg. P. 272.
- Zhao, Y., Lu, Q., Chen, D., and Wei, Y. (2006) Superhydrophobic modification of polyimide films based on gold-coated porous silver nanostructures and self-assembled monolayers. *J. Mater. Chem.* 16. pp. 4504–4509. DOI: 10.1039/B608981J.

## СПОСОБ ПОВЫШЕНИЯ ЭФФЕКТИВНОСТИ ОБЪЕМНОЙ ГИДРОФОБИЗАЦИИ ЗАЩИТНЫХ СЛОЕВ СТРОИТЕЛЬНЫХ КОНСТРУКЦИЙ

Валерия Строкова<sup>1</sup>, Христина Урманова<sup>1</sup>, Георгий Калатоzi<sup>1</sup>, Софья Неровная<sup>1\*</sup>, Любовь Шахова<sup>2</sup>

<sup>1</sup>Белгородский государственный технологический университет им. В. Г. Шухова, Белгород, Россия

<sup>2</sup>Общество с ограниченной ответственностью «Владивостокский научно-исследовательский центр строительных материалов», г. Спасск-Дальний, Россия

\*E-mail: nerovnaya.sofya@yandex.ru

### Аннотация

**Введение.** Защита и ремонт бетонных конструкций являются приоритетными задачами, некоторые решения которых представлены в стандартах, таких как EN 1504 и ГОСТ 32016–2012. Применение гидроизоляционных составов – один из основных методов защиты бетонных конструкций от воздействия воды. Гидрофобные составы широко используются для сохранения свойств бетона, обеспечивая поверхностную или объемную гидрофобизацию.

**Целью** исследования являлась разработка и обоснование нового способа повышения эффективности объемной гидрофобизации защитных слоев, выполненных из сухих строительных смесей (ССС) на основе микроцемента.

**Материалы и методы.** В качестве основного компонента сухой смеси использован микроцемент марки МЦ МикроОСТ производства ООО «Новые технологии», в качестве алюминатных компонентов рассмотрены глиноземистый (ГЦ-35 40) и высокоглиноземистый (ВГЦ-70) цементы. Сравнительную оценку гидрофобных свойств разработанных составов сухих строительных смесей на основе микроцемента проводили по показателям угла смачивания и водопоглощения. **Результаты** исследования показали, что образцы с введением алюминатной составляющей, такой как высокоглиноземистый цемент (ВГЦ), проявили высокий уровень гидрофобности и более быстрое завершение процесса набора воды в материал, относительно образцов с ГЦ-35 40, образцов контрольного состава К-1 или с альтернативными добавками (состав с Mapelastix). Показано, что введение высокоглиноземистого цемента в количестве 10–15 % обеспечивает максимальную гидрофобность для предложенного способа. Анализ формы краевого угла смачивания выявил наличие водоотталкивающей пленки на обработанной поверхности у образцов с 10 и 15 % содержанием высокоглиноземистого цемента. В отношении других покрытий отмечается их высокая резистивная способность к проникновению воды вглубь материала. Эти результаты демонстрируют высокую эффективность предложенного способа повышения объемной гидрофобизации защитных слоев, изготовленных из сухих строительных смесей и применяемых для защиты строительных конструкций от воздействия влаги и обеспечения их долговечности и прочности.

**Ключевые слова:** сухие строительные смеси; гидрофобность; алюминатная составляющая; краевой угол смачивания; водопоглощение; защитный слой; ремонтные составы.

# **Guide for Authors**

## **for submitting a manuscript for publication**

### **in the «Architecture and Engineering»**

The journal is an electronic media and accepts the manuscripts via the online submission. Please register on the website of the journal <http://aej.spbgasu.ru/>, log in and press "Submit article" button or send it via email [aejeditorialoffice@gmail.com](mailto:aejeditorialoffice@gmail.com).

Please ensure that the submitted work has neither been previously published nor has been currently submitted for publication in another journal.

#### **Main topics of the journal:**

1. Architecture
2. Civil Engineering
3. Geotechnical Engineering and Engineering Geology
4. Urban Planning
5. Technique and Technology of Land Transport in Construction

#### **Title page**

The title page should include:

The title of the article in bold (max. 90 characters with spaces, only conventional abbreviations should be used); The name(s) of the author(s); Author's(s') affiliation(s); The name of the corresponding author.

#### **Abstract and keywords**

Please provide an abstract of 100 to 250 words. The abstract should not contain any undefined abbreviations or unspecified references. Use the IMRAD structure in the abstract (introduction, methods, results, discussion).

Please provide 4 to 6 keywords which can be used for indexing purposes. The keywords should be mentioned in order of relevance.

#### **Main text**

It should have the following structure:

- 1) Introduction,
- 2) Scope, Objectives and Methodology (with subparagraphs),
- 3) Results and Discussion (may also include subparagraphs, but should not repeat the previous section or numerical data already presented),
- 4) Conclusions,
- 5) Acknowledgements (the section is not obligatory, but should be included in case of participation of people, grants, funds, etc. in preparation of the article. The names of funding organizations should be written in full).

#### **General comments on formatting:**

- Subtitles should be printed in Bold,
- Use MathType for equations,
- Tables should be inserted in separate paragraphs. The consecutive number and title of the table should be placed before it in separate paragraphs. The references to the tables should be placed in parentheses (Table 1),
- Use "Top and Bottom" wrapping for figures. Figure captions should be placed in the main text after the image. Figures should be referred to as (Fig. 1) in the text.

#### **References**

The journal uses Harvard (author, date) style for references:

- The recent research (Kent and Park, 1990)...
- V. Zhukov (1999) stated that...

## **Reference list**

The list of references should only include works that are cited in the text and that have been published or accepted for publication. Personal communications and unpublished works should only be mentioned in the text. Do not use footnotes or endnotes as a substitute for a proper reference list. All references must be listed in full at the end of the paper in alphabetical order, irrespective of where they are cited in the text. Reference made to sources published in languages other than English or Russian should contain English translation of the original title together with a note of the used language.

## **Peer Review Process**

Articles submitted to the journal undergo a double blind peer-review procedure, which means that the reviewer is not informed about the identity of the author of the article, and the author is not given information about the reviewer.

On average, the review process takes from one to five months.